

ON OPTIMIZATION OF DEMOGRAPHIC AND MIGRATION
POLICIES IN A SOCIO-ECONOMIC GROWTH MODEL

Roman Kulikowski

September 1976

Research Memoranda are interim reports on research being conducted by the International Institute for Applied Systems Analysis, and as such receive only limited scientific review. Views or opinions contained herein do not necessarily represent those of the Institute or of the National Member Organizations supporting the Institute.

Preface

The present paper was prepared within the framework of research oriented towards the investigation of analytic tools used in modelling of the regional and national development.

In particular the paper deals with the optimization of demographic and migration policies in socio-economic models.

The results obtained in the paper can be used also for the further studies of the technological change impact on the migration from the rural to urban areas.

On Optimization of Demographic and Migration
Policies in a Socio-Economic Growth Model.

Abstract

The paper deals with a socio-economic model of planned national and regional development. The development is regarded as a result of accumulation of production factors (i.e. labour, capital, etc.), which are controlled by the decision center in such a way that the consumption per head allocated among different population groups (in preworking, working, post working age) in the form of salaries, stipends, allowances for families with many children, pensions for the retired, etc., is maximum, i.e., that a given utility function attains maximum. The impact of the consumption allocation on fertility is investigated. The results obtained are used for determining the optimum demographic and migration policies for the allocation of labour force in regional systems.

1. Introduction

In recent years an increasing interest in the problems of modelling and forecasting of regional and national development can be observed. The general development process is usually accompanied by transition of production factors: the labor force and capital. The transition of labor is one of the main factors which determine the population migrations. The transition in education level, research and development, associated with the so called "scientific and technical revolution", also follows. The resulting increase in consumption per head as well as the increase of health-level is the main cause of the so called "transition in demography".

Before the transition begins life expectancy is less than 30 years. The average woman has many children but only about half of them survives. When the transition is complete life expectancy reaches 70 years, the average woman has slightly more than two children and the population grows rather slowly. Sometimes a fertility stimulating policy is needed.

Generally speaking, the transition in development processes can be studied from two points of view. The first uses the descriptive approach, which assumes the development to be predetermined by some endogeneous factors, not expressed explicitly in the model. The second approach, called normative, assumes that the growth processes can be controlled (e.g. by government activities) according to the given goals of development.

In the present research the normative approach to the development has been used. According to that approach we start with the economy, described by an extension of the neo-classic production function, with the centrally planned allocation of production factors.

As the main development goal, the integrated GNP and consumption per head has been used. Using the so called "factor coordination principle" and an extension of the classic "golden-rule of development" theorem, the best strategy of development, in terms of factor endowments can be formulated. That theory requires that the factors grow in a coordinated fashion. For example, the growth of capital (resulting out of investment strategy) is correlated with the growth of labor, keeping the capital per head on the given (generally changing exponentially in time) level.

Under the optimum strategy the consumption per head is predetermined. Since the supply of labor depends on fertility, which in turn depends on the consumption allocation (such an approach became popular in recent years due to the works of the so called "household economists"), our research is also concerned with the allocation of consumption among different population groups. The consumption should be allocated in such a way that the given utility function is maximized.

In the model discussed, the following four groups of population have been introduced:

- L_0 = part of population in pre working age,
- L_1 = the working part of population in working age,
- L_2 = the non working part of population in working age,
- L_3 = part of population in post working age.

The utility introduced in the model takes into account the consumption per head in each group L_i , $i = 0, 1...3$.

Then the optimum strategy of allocation of consumption, i.e., the salaries, can be derived. It is shown that in a stable population the optimum strategy of income allocation and optimum population policy can be coordinated. Then a fertility model, which depends on consumption per head (by L_i , $i = 0 \dots 3$) can be introduced and it is possible to find i the population growth resulting out of the optimal development policy.

Using that approach it is also possible to investigate the economic system consisting of two sectors: agriculture and the rest of the economy. The optimum allocation of production factors in this system can be derived and the impact of the technological change can be investigated. In particular, the transition in sectors employment and the resulting migration pattern between the rural and urban areas can be studied.

In the planned economy the transition of labour can be achieved, generally speaking, by two kinds of policies:

- a) the (long term) demographic policy, which affects the fertility in urban and rural areas,
- b) the (short term) migration policy, which affects the migration pattern.

The implementation of these policies requires, generally speaking, the expenditures, which reduce the expected benefits, resulting out of the optimum strategy in allocation of resources.

As shown in the paper an optimum strategy exists which takes into account the expected cost and benefits and that strategy can be derived in the numerical form. Starting with that strategy it is also possible to derive the optimum strategy of investments, personal and aggregate consumption, expenditures connected with demographic and migration policies, etc.

The general idea, which we have tried to emphasize in the present paper, is based on the belief that the optimum strategy of development should take into account (besides the economic factors such as capital investment), the socio-economic factors - (such as the demographic factors and migrations) and environment pollution impact.

The author feels very much obliged to Professor N. Keyfitz for reading the manuscript and for his valuable comments.

2. Optimum allocation of resources

Consider the socio-economic model of development shown in Fig. 1*. The general assumption is that economic growth, i.e., the output production Y , is influenced by three main feedbacks:

1. accumulation of capital K due to the investments Z_2
2. technical progress, due to the government expenditures Z_ν , $\nu = 3 \dots m$ in health, education research and development, etc., which can also be regarded as the so called aggregate consumption
3. employment L_1 which depends on demographic factors and first of all on fertility (which in turn depends on allocation of consumption among different population groups), migration, etc.

The model also uses a normative approach to planning and management of development. The decision center DC. is concerned with the optimum allocation of resources, i.e., the allocation of GNP Y , among the personal consumption (Z_1), investments (Z_2) and aggregate consumption (Z_ν , $\nu = 3 \dots m$) in such a way that the given utility function U_1 is maximum.

The Socio-economic Policy Center is concerned with the allocation of Z_1 among the different population groups in such a way that the given utility function U_2 is maximum.

In the planned economies these two decisions centers (in Poland the Planning Commission and the Committee for Prices and

* That model was studied also in Ref. (4,5).

Wages) cooperate closely to realize the common development goal.

It is assumed that the output production intensity $y(t)$, depends on a number of production (development) factors intensities, $F_v(t)$, $v = 1 \dots m$, which represent the employment ($v = 1$), capital stock ($v = 2$) and the level of health, education, research and development etc., ($v = 3, \dots m$).

Using the general methodology developed in Ref. (4) to the model investigated, it is possible to describe the mapping $\underline{z} \rightarrow \underline{f} \rightarrow y$, by the production function:

$$y(t) = Ae^{\mu t} \prod_{v=1}^m [f_v(t)]^{\beta_v}, \quad (1)$$

where $\sum_{v=1}^m \beta_v = 1$

$A, \mu =$ given positive constants. The functions f_v are generally nonlinear, dynamic operators of z_v . A typical operator of that type is:

$$f_v(t) = \delta_v \int_{-\infty}^t e^{-\delta_v(t-\tau)} [z_v(\tau - \tau_v)]^{\alpha_v} d\tau \quad *) \quad (2)$$

where $0 < \alpha_v < 1$,

δ_v given positive constants,

$z_v(\tau) =$ factor expenditure intensity.

*) The variables z_v, y_v are assumed to be continuous in time which is a matter of convenience rather than general philosophy.

It should be observed that $f_v(z_v)$ is a strictly concave, dynamic operator. There is a constant delay T_v between the input and output. The factor $f_v(t)$ depreciates in time with the time constant δ_v . As shown in [5] the formation of capital (due to the investment Z_1), or the education, research and development-level etc., (due to government expenditures z_v , $v = 3 \dots m$) can be described by (2). In the case of labour, i.e., $v = 1$, there are no inertial effects involved and it is possible to assume $T_1 = 0$, $\alpha_1 = 1$, $\delta_1 \rightarrow \infty$ so that $f_1(t) = z_1(t)$, i.e., employment is expressed in monetary terms (salaries).

It should be observed that in the planning practice instead of dealing with time variables, $y(t)$, $f_v(t)$ $v = 1 \dots m$, the integrated, discounted values:

$$Y = \int_0^T e^{-\lambda t} y(t) dt \quad (3)$$

$$F_v = \int_0^T e^{-\lambda_v t} f_v(t) dt, \quad v = 1 \dots m \quad (4)$$

where λ, λ_v , = discount rates, $F_1 = L_1$ = labour resources, T = given planning horizon; are being used.

In the case when the amount of factors F_v , $v = 1 \dots m$, is given one would like to know how the factors should change in time in order to maximize Y , subject to (4).

Using the generalized Hölder inequality

$$\int_0^T \prod_{v=1}^m \varphi_v(t) dt \leq \prod_{v=1}^m \left\{ \int_0^T |\varphi_v(t)|^{\frac{1}{\beta_v}} dt \right\}^{\beta_v}$$

$$\varphi_v(t) = \left\{ e^{-\lambda_v t} f_v(t) \right\}^{\beta_v}$$

which becomes an equality when (almost everywhere):

$$C_v |\varphi_v(t)|^{\frac{1}{\beta_v}} = |\varphi_1(t)|^{\frac{1}{\beta_1}}, \quad C_v = \text{const. } v = 2 \dots m;$$

one finds:

$$f_v(t) = \hat{f}_v(t) = \frac{F_v}{F_1} e^{(\lambda_v - \lambda_1)t} \hat{f}_1(t), \quad v = 2 \dots m \quad (5)$$

One finds also that under optimum strategy

$$\hat{Y} = Y(\hat{f}) = A \prod_{v=1}^m F_v^{\beta_v} \quad (6)$$

The obtained result indicates that Y attains the maximum value (6) when the factors $f_v(t)$, $v = 1 \dots m$, change in co-ordinated fashion. The relations (5) will be called therefore the principle of factor coordination. According to that principle the capital, education, research and development etc., should change along with employment in fixed proportions.

If the employment growth rate is λ_1 the output growth rate $\rho = \frac{\dot{Y}}{Y}$ under (5) strategy is:

$$\rho = \sum_{v=1}^m \lambda_v \beta_v + \mu = \lambda$$

The variables $Y, F_v, v = 1 \dots m$, in (3)(4) are expressed in natural units. Introducing the price p of the output Y and prices $\bar{\omega}_v = v = 1 \dots m$, for rental of factors, which satisfy the relation:

$$p = \prod_{v=1}^m \bar{\omega}_v^{\beta_v},$$

it is also possible to express (4) in monetary units $\bar{F}_v = \bar{\omega}_v F_v, v = 1 \dots m$. Assuming $f_v(t) = 1$, for $T \rightarrow \infty$ one gets by virtue of (4)

$$\bar{\omega}_v = \lambda_v \bar{F}_v = \frac{\bar{F}_v}{\tau_v}, \quad v = 1 \dots m,$$

where τ_v is the time period in which the factor original value \bar{F}_v depreciates to zero.

Since

$$F = \sum_{v=1}^m \bar{\omega}_v F_v$$

represents the total expenditure on factor endowments it is natural to assume $F = Y$. Then a problem of finding optimum values $F_v = \hat{F}_v, v=1 \dots m$ which maximum (6), can be solved. It can be shown that

$$\hat{F}_v = \frac{\beta_v}{\bar{\omega}_v} Y, \quad v = 1 \dots m \quad (7)$$

Introducing the variables $W_v = \frac{F_v}{F_1}$, $v = 2 \dots m$, one gets by virtue of (7) the following conditions for the output maximizing strategy.

$$\hat{W}_v = \frac{\beta_v}{\beta_1} \cdot \frac{\bar{\omega}_1}{\bar{\omega}_v}, \quad v = 2 \dots m$$

When \hat{F}_v , $v = 1 \dots m$, are known and the employment $f_1(t) = \ell(t)$ is given it is possible to find by using (5) and (2) the necessary expenditures $z_v(t)$, $v = 2 \dots m$, $t \in [0, T]$.

Another possible approach is to find $z_v(t)$ rather by using the factor coordination principle (5) and the constraints of the form:

$$\sum_{v=1}^m z_v(t) \leq y(t), \quad (8)$$

or

$$\sum_{v=1}^m \int_0^T z_v(t) dt \leq Y \quad (9)$$

Such an approach has been used in the Ref. [4]. In the present paper we shall deal however, with the integrated (within the planning horizon) variables. That approach simplifies the calculation and does not obscure the basic issues studied in the paper.

When the planning horizon T is long enough it is also possible (see Ref. [5]) to regard the labour supply as a result of the demographic policy, changing the fertility and the birth rate. The factor coordination principle can be used in that

case to find the best demographic policy (assuming the cost of implementation of that policy to be given).

The output maximizing strategy [5] may not satisfy the consumers and maximization of the consumption per head is assumed sometimes as the main development goal. According to that approach and factor coordination principle we would like to find $W_v = \hat{W}_v$, $v = 2 \dots m$, which maximize the consumption per head, i.e.

$$\begin{aligned}
 U_1 &= p \frac{Y}{F_1} - \sum_{v=2}^m \bar{\omega}_v \frac{F_v}{F_1} = \\
 &= p A \sum_{v=2}^m W_v^{\beta_v} - \sum_{v=2}^m \bar{\omega}_v W_v
 \end{aligned} \tag{10}$$

Since U_1 is a strictly concave differential function the conditions of optimality become:

$$\begin{aligned}
 \frac{dU_1}{dW_i} &= \beta_i p A W_i^{\beta_i-1} \prod_{\substack{v=2 \\ v \neq i}}^m W_v^{\beta_v} - \bar{\omega}_i = 0, \\
 i &= 2 \dots m
 \end{aligned} \tag{11}$$

Denoting $\ln W_i = v_i$, $\frac{W_i}{\beta_i p A} = a_i$, $i = 2 \dots m$, the system of equation (9) becomes

$$(\beta_i - 1) v_i + \sum_{\substack{v=2 \\ v \neq i}}^m \beta_v v_v = a_i, \quad i = 2 \dots m \tag{12}$$

Assuming that

$$\begin{vmatrix} \beta_2 - 1, & \beta_3 & \dots & \beta_m \\ - & - & - & - \\ \beta_2, & \beta_3 & \dots & \beta_m - 1 \end{vmatrix} \neq 0,$$

one can easily find the set of positive numbers $W_\nu = \hat{W}_\nu, \nu = 2 \dots m,$ which constitute the solution of the linear system of equations (12).

Setting $\hat{W}_\nu, \nu = 2 \dots m,$ into (10) one can derive also the maximum consumption per head employed or, more accurately, the gross salary $\bar{\omega}_1$.

The strategy described by (12) can be regarded as an extension of the classical "golden rule theorem", which was originally proved for $m = 2$ and an exponentially growing labour. Since in the present model we are dealing with the integrated variables it is possible to avoid the last assumption which is very restrictive.

It should be observed that in the present model we can also avoid the assumption made in classical golden rules, that factor ratios, i.e., capital/labour = $W_1 = \text{const.}$ at each time instant. That assumption is replaced by less restrictive factor coordination principle.

Under factor coordination principle (5) and consumption maximizing strategy (12) the factors grow with different rates, i.e.

$$\frac{\hat{f}_\nu(t)}{\hat{f}_1(t)} = \hat{W}_\nu e^{(\lambda_\nu - \lambda_1)t}, \quad \nu = 2 \dots m \quad (13)$$

However, when the employment intensity $\ell(t) = f_1(t)$ is given exogeneously the $\hat{z}_v, v = 2 \dots m$ expenditures, derived by solving the equations

$$\delta_v \int_{-\infty}^t e^{-\delta_v(t-\tau)} \hat{z}_v^{\alpha_v} (\tau - T_v) d\tau = \hat{W}_v \ell(t)$$

i.e.

$$\hat{z}_v(t - \tau_v) = \left\{ \frac{\hat{W}_v}{\delta_v} \left[\delta_v \ell(t) + \ell'(t) \right] \right\}^{\frac{1}{\alpha_v}},$$

may violate the constraints (8), (9). A possibility also exists to solve the problem in the expenditures space Z , i.e.

$$\max_{\underline{z} \in Z} U_1(\underline{z})$$

subject to the constraints (8), (9). When T is a short time interval the strategy $\underline{z}(t) = \hat{\underline{z}}(t), t \in [0, T]$, obtained in that way, may not satisfy the relations

$$\frac{F_v(\hat{\underline{z}})}{F_1(\hat{\underline{z}})} = \hat{W}_v \quad v = 2 \dots m \quad (14)$$

However, it is possible to show, that when the factors reach the required levels, i.e. $\bar{w}_v = \hat{W}_v, v = 2 \dots m$, the growth will follow the optimum strategy (13). The obtained value of $U_1(\hat{\underline{W}})$ can be then regarded as the maximum possible consumption per working head, in the stabilized situation (14).

3. Optimum allocation of consumption and the demographic policy impact.

In the present section we shall assume that $\bar{\omega}_1 = U_1$ is given (determined by the strategy of allocation of resources \underline{z}) and the problem consists in finding the best strategy of allocation of $\bar{\omega}_1$ among different population groups. For that reason $\bar{\omega}_1$ will be regarded as the average gross salary imputed to one worker in the planning interval T . The standard government policy in the planned economy is to impose a tax t_1 on the

gross salary $\bar{\omega}$, so that net average wage per worker is $\omega_1 = \bar{\omega}_1(1-t_1)$. The difference $\bar{\omega}_1 t_1$ is used for financial support of different population groups in the form of allowances for families with many children, stipends, paid leaves for working mothers, pensions for retired people, etc.

The socio-economic policy center (see Fig. 1) is therefore concerned with the best allocation of $\bar{\omega}_1$ among the different population groups L_i , $i = 0, 1, 2, 3$. We shall assume a "salary" ω_i to be attached to each L_i group, so that the following condition holds:

$$\bar{\omega}_1 \geq \sum_{i=0}^3 \omega_i \frac{L_i}{L_1}, \quad (15)$$

where L_i are group-population resources in $[0, T]$, i.e.

$$L_i = \int_0^T l_i(t) dt, \quad l_i(t) = \text{population number in the}$$

year t in group i .

The L_i are closely related to the numbers of population in the age sub-intervals:

N_0 = number of people in the preworking age $[0, \alpha]$,

N_1 = number of people in the working age $[\alpha, \beta]$

N_2 = number of people in the post-working age $[\beta, \omega]$

Obviously not all the people in the working age are employed and it is necessary to split the N_1 into two parts $L_1 = X N_1$ = the working part of N_1 , $L_2 = (1-X) N_1$ = the non-working part of N_1 .

As a result we get:

$$\bar{\omega}_1 \geq \sum_{i=0}^3 \omega_1 \frac{L_i}{X N_1} = \omega_0 \frac{N_0}{X N_1} + \omega_1 + \omega_2 \frac{1-X}{X} + \omega_3 \frac{N_2}{X N_1} \quad (16)$$

It should be noted that the constraint (16) does not take into account the allocation of consumption within the family, which is the basic social unit with common household. Assuming that the population investigated consists of M typical families with a_i members of each group L_i (i.e. $L_i = M a_i$, $i = 0, 1, 2, 3$) and that the corresponding members consume an average k_i , the family budget constraints can be written in the form:

$$\sum_{i=0}^3 a_i \omega_i + I = \sum_{i=0}^3 a_i k_i + s$$

Where I denotes the additional (besides employment) forms of family income, s = family savings.

The problems of allocation of consumption within the family will not be studied here. However, when k_i, I, s are given, it is possible to supply (16) with the additional constraints of the form:

$$\sum_{i=0}^3 a_i \omega_i \leq \sum_{i=0}^3 a_i k_i + s - I \quad (16)'$$

The socio-economic policy center is concerned with the maximization of an utility function which takes into account the consumption by different L_i groups and the leisure time (which has a value proportional to the cost of consumption lost,

i.e., $(1-X)\omega_i$) In the present paper the simple utility which takes into account these factors will be investigated:

$$\begin{aligned}
 U_2 &= \omega_0^{\pi_0} (\omega_1 X)^{\pi_1^1} [\omega_1(1-X)]^{\pi_1^2} \omega_2^{\pi_2} \omega_3^{\pi_3} = \\
 &= X^{\pi_1^1} (1-X)^{\pi_1^2} \prod_{i=0}^3 \omega_i^{\pi_i}, \quad (17)
 \end{aligned}$$

where $\pi_1 = \pi_1^1 + \pi_1^2$, $\sum_{i=1}^3 \pi_i = \pi$

The value of π generally speaking, should be less unity, what corresponds to the decreasing return to scale with respect to the consumption growth. The impact of deterioration of environmental quality due to the increased consumption can be handled by introducing in (17) additional factor of the form:

$$\prod_{i=0}^3 (e_i \omega_i)^{-\varepsilon_i}, \quad e_i, \varepsilon_i = \text{given positive constants, which}$$

specifies the L_i group contributions to the environment pollution. The net result is a decrease of π_i by ε_i , i.e. the π_i numbers in (17) should be replaced by $\bar{\pi}_i = \pi_i - \varepsilon_i$, and

$$\bar{\pi} = \pi - \sum_{i=0}^3 \varepsilon_i.$$

It should be noted that introducing a typical form of utility (17) rather than a general function $U(\omega_0 \dots \omega_3, X \dots)$, we are able to derive more specific and concrete relations. The product form of (17) enables substitutions and preferences among variables ω_i , $i = 0, 1, 2, 3$, to take place. The function (17) is

strictly convex so the unique optimum strategy (in terms of ω_i) exists for the given budgetary constraints. The π_i , $i = 0, 1, 2, 3$, coefficients should be regarded as the components of the socio-economic policy objectives. They determine the socio-economic development strategy in terms of ω_i .

The main problem which faces the socio-economic policy center, is therefore to find the $\omega_i = \hat{\omega}_i$ $i = 0, 1, 2, 3$, which maximize $U_2(\underline{\omega})$ subject to (16). Assuming that

$\frac{N_0}{N_1}$, $\frac{N_2}{N_1}$ do not depend much on the ω_i , $i = 0, 1, 2, 3$, it is possible to show that the optimum values $\hat{\omega}_i$, which maximize (17)

subject to (16) become:

$$\hat{\omega}_0 = \frac{\pi_0}{\pi} \bar{\omega}_1 X \frac{N_1}{N_0}, \quad \hat{\omega}_1 = \frac{\pi_1}{\pi} \hat{\omega}_1, \quad \hat{\omega}_2 = \frac{\pi_2}{\pi} \bar{\omega}_1 \frac{X}{1-X}, \quad \hat{\omega}_3 = \frac{\pi_3}{\pi} \bar{\omega}_1 X \frac{N_1}{N_2} \quad (18)$$

The advantage of relations (18) is that they are simple enough so it is possible to use the statistical data regarding $\frac{N_1}{N_0}$, $\frac{N_1}{N_2}$, X, ω_i , $i = 1, 2, 3$, and identify the past policy objectives in terms of π_i parameters. The utility parameters determined ex post can be then used ex ante when the model is used for forecasting purposes.

When (18) strategy is used one gets

$$U_2(\hat{\underline{\omega}}) = \bar{\omega}_1^\pi X^\alpha (1-X)^\beta \prod_{i=0}^3 \left(\frac{\pi_i}{\pi}\right)^{\pi_i} \left(\frac{N_1}{N_0}\right)^{\pi_0} \left(\frac{N_1}{N_2}\right)^{\pi_3}, \quad (19)$$

where

$$\alpha = \pi_0 + \pi_1^1 + \pi_2 + \pi_3$$

$$\beta = \pi_1^2 - \pi_2.$$

When $\alpha > 0$, $\beta > 0$, it is possible to find $X = \hat{X}$, which maximum (19). Since the function $U_2(X)$ is concave we find \hat{X} by solving the equations

$$U_2'(\hat{X}) = 0$$

which yields

$$\hat{X} = \frac{\alpha}{\alpha + \beta} = \frac{\pi - \pi_1^2}{\pi - \pi_2} \quad (20)$$

as the optimum leisure to working time ratio of the population concerned. That coefficient does not usually change much. In Poland, in the years 1970-1973, X was around 0,83.

Assuming X to be given we can be concerned now with the utility

$$U_2 = \bar{U}_2 \left(\frac{N_1}{N_0} \right)^{\pi_0} \left(\frac{N_1}{N_2} \right)^{\pi_3}, \quad \bar{U}_2 = \text{const.} \quad (21)$$

The simplest situation exists when we deal with a stable population, having the growth rate r . In that case (see Ref [3]):

$$\frac{N_1}{N_0} = \frac{\int_{\alpha}^{\beta} e^{-ra} p(a) da}{\int_0^{\alpha} e^{-ra} p(a) da},$$

$$\frac{N_1}{N_2} = \frac{\int_{\alpha}^{\beta} e^{-ra} p(a) da}{\int_{\beta}^{\omega} e^{-ra} p(a) da}$$

where $p(a)$ = number-living column of the life table with radix unity - the function determining survivorship.

Assuming, as an example:

$$p(a) = \bar{p} e^{-\lambda a}, \quad \bar{p}, \lambda > 0,$$

and $\frac{\beta}{\alpha} = 3, \quad \frac{\omega}{\alpha} = 4$

one gets

$$\frac{N_1}{N_0} = R(1 + R), \quad \frac{N_1}{N_2} = \frac{1+R}{R^2}, \tag{22}$$

where $R = e^{-(\lambda+r)\alpha}$

It should be observed that

$$\left(\frac{N_1(r)}{N_0(r)} \right)' = (1 + 2R) \frac{dR}{dr} = -\alpha(1 + 2R) < 0$$

$$\left(\frac{N_1(r)}{N_2(r)} \right)' = -\frac{2+R}{R^3} \frac{dR}{dr} = \alpha \frac{2+R}{R^2} > 0$$

So an increase in population growth rate r decreases $\frac{N_1}{N_0}$ and increases $\frac{N_1}{N_2}$. As a result of these changes the population growth may increase the financial support for retired and may

result in an increase of utility. At the same time the decreased financial support for the L_0 group may reduce that benefit. Samuelson (Ref. [10]) has shown that when consumption per capita is divided between two groups of population (productive and economical dependent) the golden rule favours population growth. After finding the best consumption strategy it is then possible to find the optimum value of population growth rate which maximizes the utility.

It should be observed that the utility (17) differs from the Samuelson formulation. First of all (17) takes into account the allocation of consumption in terms of salaries mainly. Obviously, in order to have a model which should explain how the optimum stable growth rate \hat{r} is related to the national development it is necessary to take also into account a number of non-economical factors and objectives. First of all the effects of depletion of natural resources and deterioration of environment due to population congestion should be introduced in the utility function. It is also necessary to take into account the parents happiness resulting out of family life, i.e. having children and grandparents. That effect can be introduced in (21) by assuming

$$\bar{U}_2 = \text{const.} \left(\frac{N_0}{N_1} \right)^{\rho_0} \left(\frac{N_2}{N_1} \right)^{\rho_3}, \quad \rho_0, \rho_3 > 0 \quad (22)$$

Then, in order to have a more realistic model, which could be used for finding the optimum growth rate \hat{r} for the population studied it is necessary to replace π_0, π_3 in (21) by

$$\bar{\pi}_0 = \pi_0 - \varepsilon_0 - \rho_0, \quad \bar{\pi}_3 = \pi_3 - \varepsilon_3 - \rho_3, \quad \text{where } \varepsilon_0, \varepsilon_3 \text{ represent the congestion effect.}$$

Assuming that an idealised population has arrived under a socio-economic and demographic policy to a stable development we can formulate the corresponding necessary and sufficient condition for that policy to be optimum. In other words we shall find the conditions under which $r = \hat{r}$ maximizes the utility function (21).

For that purpose one can use the relations:*)

$$\frac{N_i'(r)}{N_i(r)} = -T_i(r), \quad i = 0, 1, 2, \quad (23)$$

where $T_i(0)$ is the average age in N_i class.

It is possible to show that

$$\left(\frac{N_1(r)}{N_0(r)}\right)' = \frac{N_1(r)}{N_0(r)} [T_0(r) - T_1(r)] < 0,$$

$$\left(\frac{N_1(r)}{N_2(r)}\right)' = \frac{N_1(r)}{N_2(r)} [T_2(r) - T_1(r)] > 0.$$

Then, the necessary condition of optimality becomes

$$U_2'(r) = U_2(r) \varphi(r) = 0, \quad (24)$$

where

$$\varphi(r) = \bar{\pi}_0 [T_0(r) - T_1(r)] + \bar{\pi}_3 [T_2(r) - T_1(r)].$$

The sufficient condition of optimality for $r = \hat{r}$, (which is the unique solution of (24)) becomes:

$$U_2''(\hat{r}) = U_2(\hat{r}) \varphi'(\hat{r}) < 0. \quad (25)$$

The conditions (24) (25) can be also written:

$$\frac{T_1(\hat{r}) - T_0(\hat{r})}{T_2(\hat{r}) - T_1(\hat{r})} = \frac{\pi_3}{\pi_0}, \quad \frac{T_1'(\hat{r}) - T_0'(\hat{r})}{T_2'(\hat{r}) - T_1'(\hat{r})} > \frac{\bar{\pi}_3}{\bar{\pi}_0} \quad (26)$$

It can be shown that

$$\frac{dU_2}{d\alpha} < 0, \quad \frac{dU_2}{d\beta} > 0,$$

so there is no optimum value of age limits α, β maximizing utility. However, these parameters can be used as additional demographic policy variables. For example, the conditions (26) can be satisfied not only by changing r but as well by changing the α, β , parameters. An increase of the lower working age limit α , will increase $T_0(r)$ and $T_1(r)$ but it has no effect on

*) I am indebted to Prof. N. Keyfitz for suggesting that approach to me.

$T_2(r)$. In the same way an increase of β , increases $T_1(r), T_2(r)$ but not $T_0(r)$. An increase of ω , (due to the better health services) change $T_2(r)$ but not $T_0(r)$ and $T_1(r)$.

Regarding the $\bar{\pi}_0, \bar{\pi}_3$ parameters as instruments of long term socio-economic policy it is possible to see that the optimality conditions (26) can be also satisfied by changing $\frac{\bar{\pi}_3}{\bar{\pi}_0}$. These two policies should be coordinated in order to satisfy the equilibrium conditions (26). When the demographic policy is coordinated, according to (26), the supply of labour and the development strategy (derived in Sec.2) is completely determined.

In the model investigated so far we have neglected the possible impact of fertility changes (due to the changes in $\omega_i, i = 0,1,2,3$) on the population groups N_0, N_1, N_2 .

In order to find that impact it is necessary to introduce a fertility model, which takes into account the existing empirical facts and theories. There is vast literature on that subject (see for example the survey given in Ref.[2]). In the micro-economic analysis of fertility one can identify two distinct kinds of models: those which apply the traditional micro-economic models and those that apply Becker-Lancaster (Ref. [1,6]) methods of analysis. The traditional models can be classified at least in four groups.

The first group regards children as a by-product of sexual activity so that a decrease of marriage age increases the number of children per family. The second group regards children as investment goods so the parents choose between the current and

future consumption. According to that theory when $\frac{\omega_2}{\omega_1}$ increases the fertility should decrease (because the parents are not so much dependent at retirement on the financial support of their children). The third group regards children as consumption goods, i.e. the parents choose between children and all other commodities. An increase in $\frac{\omega_0}{\omega_1}$ would increase the fertility because the cost of having children decreases (as compared to the cost of other commodities). It is argued, however, that an increase of ω_1 may not increase the number of children because the cost of bringing up a child is less for less income families. It was argued for example that fertility as a function of income (i.e. ω_1) takes an U form shape.

The fourth group of models assumes that the parents make a choice between child quality and quantity as consumer goods. The Becker-Lancaster approach is based on the so called "household economy". Becker studied for example, fertility in terms of commodities such as "quality of children", which is produced by inputs of goods and parental time. More children here need more parental time. If the parents work they have no time for bringing up the children. Taking into account the existing theories in fertility, and their relations to our ω_i , $i = 0, 1, 2, 3$, variables, it is possible to introduce the following fertility function:

$$F(\underline{\omega}) = a(\underline{y}) \left(\frac{\omega_0}{\omega_1}\right)^{\alpha_0} \left(\frac{\omega_1}{\omega_3}\right)^{\alpha_3} x^{-\alpha_1} (1-x)^{\alpha_2}, \quad (27)$$

where $\left(\frac{\omega_0}{\omega_1}\right)^{\alpha_0}$ takes into account the increase in fertility due to an increase of the financial support for children,

$\left(\frac{\omega_1}{\omega_3}\right)^{\alpha_3}$ takes into account the decrease in fertility by increased support of the retired,

$X^{-\alpha_1}$ the decrease of fertility resulting out of increased working time (the working parents have no time to raise children)

$(1-X)^{-\alpha_2}$ the increase of fertility out of increased leisure time

$a(y)$ takes into account all the exogeneous factors, such as ethical views, religion, etc.

In the case when fertility increases along with ω_1 (starting from $\omega_1 = \tilde{\omega}_1$) it is necessary to assume $\alpha_3 - \alpha_0 < 0$ and $\alpha_3 - \alpha_0 > 0$ in the opposite case ($\omega_1 < \tilde{\omega}_1$).

Using the fertility model proposed and assuming that the model parameters do not depend on the age structure the constraints (16) can be now written in the form:

$$\bar{\omega}_1 \geq \frac{\omega_0}{X} \cdot \frac{N_0(r)}{N_1(r)} + \omega_1 + \omega_2 \frac{1-X}{X} + \frac{\omega_3}{X} \frac{N_2(r)}{N_1(r)}, \quad (28)$$

where r can be computed by solving the equation

$$F(\underline{\omega}) \int_0^{\alpha} e^{-ra} p(a) m(a) da = 1 \quad (29)$$

where

$m(a)$ = the probability of a woman a years of age having a child in the interval $(a, a + da)$.

Now we can try to solve the problem of finding $\omega_i = \hat{\omega}_i$, $i = 0, 1, 2, 3$, which maximize (17) subject to the nonlinear constraints (28) (29). That problem can be solved numerically by using, e.g. the well known gradient projection technique.

It should be observed that using the present model we are able to endogenize (at least in theory) most of the demographic parameters, which affect the labour supply and optimum growth strategies. However, many parameters expressed by vector \underline{y} in (27) remain still exogeneous.

4. Optimization of migration policies in regional systems.

In section 2 we dealt with allocation of resources in integrated one sector economy. In the present section we shall assume that we have n different regional systems, each described by different utility functions $U_i (F_{vi})$. The central government is concerned with the allocation of resources among different regions in such a way that the resulting utility

$$U = \sum_{i=1}^n U_i (F_{vi}) \quad (30)$$

attains maximum, subject to the constraints

$$\sum_{i=1}^n F_{vi} \leq F_v, \quad v = 1 \dots m \quad (31)$$

The regional utilities can be assumed, according to (6), in the form:

$$U_i = R_i q_i \prod_{v=1}^m F_{vi}^{\beta_{vi}}, \quad (32)$$

where

$$\beta_i = \sum_{v=1}^m \beta_{vi} < 1, \quad q_i = 1 - \beta_i,$$

R_i = given positive constants.

The optimum allocation strategies $F_{vi} = \hat{F}_{vi}$ for the simple case $\beta_{vi} = \beta_v$, $i = 1 \dots n$, become [4]

$$\hat{F}_{vi} = \frac{R_i}{R} F_v, \quad R = \sum_{i=1}^n R_i, \quad v = 1 \dots m \quad (33)$$

Under optimum strategy (33) one gets:

$$\hat{U} = U(\hat{F}_{vi}) = R^q \prod_{v=1}^m F_v^{\beta_v}, \quad q = 1 - \sum_{v=1}^m \beta_v > 0 \quad (34)$$

Generally speaking, the introduction of regional transition of production factors gives us more possibilities to realize the optimum allocation of factor's strategies, formulated in sec. 2, than in the closed simple sector economic system.

By virtue of (33) one finds in particular the optimum labour allocation strategy:

$$\frac{L_i}{L} = \frac{R_i}{R}, \quad i = 1 \dots n,$$

where L is the total labour force.

If the labour is not allocated in the optimum manner a reallocation process is needed. The reallocation of labour by means of migrations may be connected with additional costs and one would like to know what are the net benefits resulting out of labour transition, or - what is the best migration strategy. In order to find that strategy we start with the following benefit function:

$$\Delta U = \hat{U} - \sum_{i=1}^m R_i^q \prod_{v=1}^m [F_{vi}]^{\beta_{vi}}, \quad (34)$$

which says how much the economy will gain when instead of the existing allocation of resources F_{vi} , $v = 1 \dots m$, $i = 1 \dots n$, one uses the optimum strategy \hat{F}_{vi} , $v = 1 \dots m$, $i = 1 \dots n$. (33)

In particular, consider a system consisting of two sectors, such as the agriculture and the rest of the economy. During the transition period the labour migrates from the country to urban centers. In the planned economy that migration process can be influenced by government policy, which is motivated by the expected cost-benefits arguments. In order to find out the best policy, in that respect it is necessary to investigate a model with expected labour supplies and demands. Assuming in our general model $m = 1$, $n = 2$, $\beta_{11} = \beta_{12} = \beta$, the formula (34) can be written in the following form:

$$\Delta U = \hat{U} - R_1^q L_1^\beta - R_2^q L_2^\beta.$$

Since

$$\hat{L}_1 = \frac{R_1}{R} L, \quad \hat{L}_2 = \frac{R_2}{R} L,$$

one gets

$$\hat{U} = R^q L^\beta$$

Assume that the labour supply in the two regions investigated to be \bar{L}_1 , \bar{L}_2 respectively ($\bar{L}_1 + \bar{L}_2 = L$), and $\hat{L}_1 > \bar{L}_1$, $\hat{L}_2 < \bar{L}_2$. The difference between demands \hat{L}_1 , \hat{L}_2 and supplies \bar{L}_1 , \bar{L}_2 can be made zero by introducing migration L_μ , i.e.,

$$\hat{L}_1 = \bar{L}_1 + L_\mu, \quad \hat{L}_2 = \bar{L}_2 - L_\mu.$$

Then the problem boils down to finding $L_\mu = \hat{L}_\mu$, which maximize the benefits:

$$\Delta (L_\mu) = R_1^q (\bar{L}_1 + L_\mu)^\beta + R_2^q (\bar{L}_2 - L_\mu)^\beta - C_\mu (L_\mu), \quad (35)$$

where $C_\mu (L_\mu)$ = migration costs.

In the more general case one can assume that \bar{L}_1, \bar{L}_2 depend on the vectors of variables $(\underline{\pi}^1, \underline{\pi}^2)$ representing the components of the socio-economic and demographic policies in the two regions respectively and (35) can be replaced by

$$\Delta (L_\mu, \underline{\pi}^1, \underline{\pi}^2) = U_1 [\bar{L}_1(\underline{\pi}^1) + L_\mu] + U_2 [\bar{L}_2(\underline{\pi}^2) - L_\mu] - C [L_\mu]. \quad (36)$$

The present simple model can be easily generalized to include the migrations among the n given regions, as well as the costs of transition of all the remaining factors, and first of all - the transfer of capital.

It should be observed that the demographic policy is especially effective in the case of long planning intervals. In the case of short planning intervals more effective is the optimal migration policy. The general problems of migration policy and migration models were studied in many papers (see Ref. [9,11]). In the present paper we are concerned mainly with the optimization of migration and demographic policies within the general framework of complex socio-economic development.

It should be also observed that in order to have a good normative model for investigation of the optimum demographic and migration policies it is necessary to take into account the

technological change impact and the comparative advantages, which determine the regional development opportunities.

Such a model, called MRI has been constructed recently at the Polish Academy of Sciences (see Ref.[4]) (the general structure of that model is shown in Fig. 1). Using that model we were able to find the forecasts of demands for labour in different sectors of the Polish economy. In particular we were able to derive the forecasts of labour demands in agriculture ($\hat{L}_a(t)$) and the rest of the economy ($\hat{L}_r(t)$) (up to 1985) for different development strategies, taking into account such factors as the expected changes of terms of trade in foreign trade, change in technology of production, change of labour efficiency, etc. Generally speaking the demands $\hat{L}_r(t)$, $\hat{L}_a(t)$, has differed from the expected forecasts of natural supply of labour in agriculture $\bar{L}_a(t)$ and the rest of the economy: $\bar{L}_r(t)$. The expected natural migration forecasts between the rural and urban areas shows that natural migration will be unable to solve the problem so the control of migration seems to be inevitable. In the research, which is now under way, we are trying to find the expected benefits, which result out of the changes in general development strategies, the necessary labour migrations, and cost connected with the induced migrations. The migration costs in Poland are connected mainly with building new houses and other facilities in urban areas.

According to some forecasts about 7 ÷ 10 millions of people should be transferred from the country to urban areas up to the year 2000. That amount of migrants creates a difficult problem

in the construction of new houses and other expenditures. According to some opinions in the long run a demographic policy which would increase the present slow demographic growth at large cities, like Warszawa (5,4 per 1000 in 1975) and - decrease (about three times larger) growth in the country - would be beneficiary. Since the percentage of people employed by government is bigger in the cities than in the country a program of stimulation of fertility by means of increasing $\frac{\omega_0}{\omega_1}$ would affect first of all the urban population.

However, the social cost of growing labour in the country is generally less than in large cities. An important problem for national and regional optimum planning consists (Ref.[7]), therefore in deriving the strategy of allocation of the expenditures C_μ , and the best strategy of the demographic policy (in terms of π^1, π^2) in such a way that the benefits (36) attain maximum. Using the methodology proposed one can derive also the optimum strategies in allocation of the F_ν factors (in particular the labour force L_1) and the utility in terms of $\omega_i, i = 0, 1, 2, 3$.

The optimum values of factors $F_\nu, \nu = 2 \dots m$ derived in that manner can be also used for finding the demands for employment in non productive sectors of the economy such as education, health service, research & development, etc. (which was in Poland in 1973 almost 13% of the total employment with an increasing tendency).

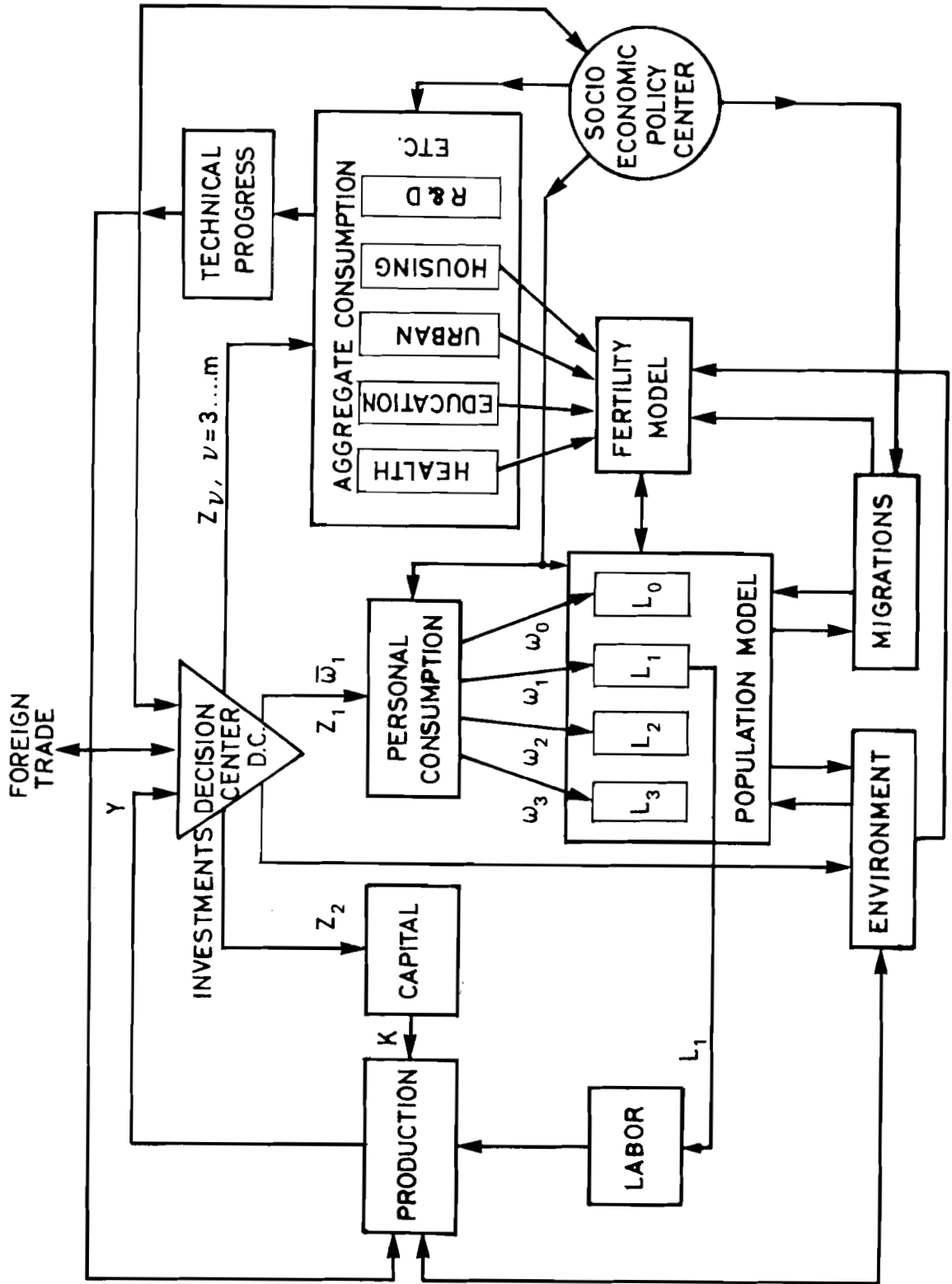

Figure 1. Socio-economic model of development.

References

- [1] Becker, G.S. "A Theory of the Allocation of Time",
"Economic Journal", Sept., 1965
- [2] Cochrane, S.H. "Children as By-products, Investment Goods
and Consumer Goods: A Review of Some Micro-economic
Models of Fertility." "Population Studies" No.3, 1975.
- [3] Keyfitz, N. "Introduction to the Mathematics of Population"
Addison-Wesley, Reading, Mass. 1968.
- [4] Kulikowski, R. "Long-Term Normative Model of Development"
International Institute for Applied Systems Analysis
Conference Paper, Sept. 1976.
- [5] Kulikowski, R. "Optimization of Demographic Policy in
Socio-economic Growth Models", Research Memorandum
RM - 76 -54, June 1976, IIASA.
- [6] Lancaster, K. "A New Approach to Consumer Theory" Journal
of Political Economy, April 1966.
- [7] Okolski, M. "Polityka Demograficzna," (Demographic Policy",
in Polish), Warszawa PWN, 1974.
- [8] Pitchford, J.D. Population in Economic Growth, North
Holland/American Elsevier, Amsterdam, London, 1974.
- [9] Rogers, A. Introduction to Multiregional Mathematical
Demography, John Wiley & Sons, New York, 1975.
- [10] Samuelson, P.A. "The Optimum Growth Rate for Population"
International Economic Review, Oct. 1975
- [11] Willekens, F.J. "Analytics of Multiregional Population
Distribution Policy" Ph. Dissertation, North Western
University, Evanston, Ill. June 1976.