

Interim Report

IR-05-072

Speciation: More Likely through a Genetic or through a Learned Habitat Preference?

J. B. Beltman (beltman@rulsfb.leidenuniv.nl)
Johan A.J. Metz (metz@rulsfb.leidenuniv.nl)

Approved by

Ulf Dieckmann
Program Leader, ADN

December 2005



The Adaptive Dynamics Network at IIASA fosters the development of new mathematical and conceptual techniques for understanding the evolution of complex adaptive systems.

Focusing on these long-term implications of adaptive processes in systems of limited growth, the Adaptive Dynamics Network brings together scientists and institutions from around the world with IIASA acting as the central node.

Scientific progress within the network is collected in the IIASA Studies in Adaptive Dynamics series.

- No. 1 Metz JAJ, Geritz SAH, Meszéna G, Jacobs FJA, van Heerwaarden JS: *Adaptive Dynamics: A Geometrical Study of the Consequences of Nearly Faithful Reproduction*. IIASA Working Paper WP-95-099 (1995). van Strien SJ, Verduyn Lunel SM (eds): *Stochastic and Spatial Structures of Dynamical Systems*, Proceedings of the Royal Dutch Academy of Science (KNAW Verhandelingen), North Holland, Amsterdam, pp. 183-231 (1996).
- No. 2 Dieckmann U, Law R: *The Dynamical Theory of Coevolution: A Derivation from Stochastic Ecological Processes*. IIASA Working Paper WP-96-001 (1996). *Journal of Mathematical Biology* 34:579-612 (1996).
- No. 3 Dieckmann U, Marrow P, Law R: *Evolutionary Cycling of Predator-Prey Interactions: Population Dynamics and the Red Queen*. IIASA Preprint (1995). *Journal of Theoretical Biology* 176:91-102 (1995).
- No. 4 Marrow P, Dieckmann U, Law R: *Evolutionary Dynamics of Predator-Prey Systems: An Ecological Perspective*. IIASA Working Paper WP-96-002 (1996). *Journal of Mathematical Biology* 34:556-578 (1996).
- No. 5 Law R, Marrow P, Dieckmann U: *On Evolution under Asymmetric Competition*. IIASA Working Paper WP-96-003 (1996). *Evolutionary Ecology* 11:485-501 (1997).
- No. 6 Metz JAJ, Mylius SD, Dieckmann O: *When Does Evolution Optimize? On the Relation Between Types of Density Dependence and Evolutionarily Stable Life History Parameters*. IIASA Working Paper WP-96-004 (1996).
- No. 7 Ferrière R, Gatto M: *Lyapunov Exponents and the Mathematics of Invasion in Oscillatory or Chaotic Populations*. *Theoretical Population Biology* 48:126-171 (1995).
- No. 8 Ferrière R, Fox GA: *Chaos and Evolution*. IIASA Preprint (1996). *Trends in Ecology and Evolution* 10:480-485 (1995).
- No. 9 Ferrière R, Michod RE: *The Evolution of Cooperation in Spatially Heterogeneous Populations*. IIASA Working Paper WP-96-029 (1996). *The American Naturalist* 147:692-717 (1996).
- No. 10 van Dooren TJM, Metz JAJ: *Delayed Maturation in Temporally Structured Populations with Non-Equilibrium Dynamics*. IIASA Working Paper WP-96-070 (1996). *Journal of Evolutionary Biology* 11:41-62 (1998).
- No. 11 Geritz SAH, Metz JAJ, Kisdi É, Meszéna G: *The Dynamics of Adaptation and Evolutionary Branching*. IIASA Working Paper WP-96-077 (1996). *Physical Review Letters* 78:2024-2027 (1997).
- No. 12 Geritz SAH, Kisdi É, Meszéna G, Metz JAJ: *Evolutionary Singular Strategies and the Adaptive Growth and Branching of the Evolutionary Tree*. IIASA Working Paper WP-96-114 (1996). *Evolutionary Ecology* 12:35-57 (1998).
- No. 13 Heino M, Metz JAJ, Kaitala V: *Evolution of Mixed Maturation Strategies in Semelparous Life-Histories: The Crucial Role of Dimensionality of Feedback Environment*. IIASA Working Paper WP-96-126 (1996). *Philosophical Transactions of the Royal Society of London Series B* 352:1647-1655 (1997).
- No. 14 Dieckmann U: *Can Adaptive Dynamics Invade?* IIASA Working Paper WP-96-152 (1996). *Trends in Ecology and Evolution* 12:128-131 (1997).
- No. 15 Meszéna G, Czibula I, Geritz SAH: *Adaptive Dynamics in a 2-Patch Environment: A Simple Model for Allopatric and Parapatric Speciation*. IIASA Interim Report IR-97-001 (1997). *Journal of Biological Systems* 5:265-284 (1997).
- No. 16 Heino M, Metz JAJ, Kaitala V: *The Enigma of Frequency-Dependent Selection*. IIASA Interim Report IR-97-061 (1997). *Trends in Ecology and Evolution* 13:367-370 (1998).
- No. 17 Heino M: *Management of Evolving Fish Stocks*. IIASA Interim Report IR-97-062 (1997). *Canadian Journal of Fisheries and Aquatic Sciences* 55:1971-1982 (1998).
- No. 18 Heino M: *Evolution of Mixed Reproductive Strategies in Simple Life-History Models*. IIASA Interim Report IR-97-063 (1997).
- No. 19 Geritz SAH, van der Meijden E, Metz JAJ: *Evolutionary Dynamics of Seed Size and Seedling Competitive Ability*. IIASA Interim Report IR-97-071 (1997). *Theoretical Population Biology* 55:324-343 (1999).
- No. 20 Galis F, Metz JAJ: *Why Are There So Many Cichlid Species? On the Interplay of Speciation and Adaptive Radiation*. IIASA Interim Report IR-97-072 (1997). *Trends in Ecology and Evolution* 13:1-2 (1998).

- No. 21 Boerlijst MC, Nowak MA, Sigmund K: *Equal Pay for all Prisoners/ The Logic of Contrition*. IIASA Interim Report IR-97-073 (1997). American Mathematical Society Monthly 104:303-307 (1997). Journal of Theoretical Biology 185:281-293 (1997).
- No. 22 Law R, Dieckmann U: *Symbiosis Without Mutualism and the Merger of Lineages in Evolution*. IIASA Interim Report IR-97-074 (1997). Proceedings of the Royal Society of London Series B 265:1245-1253 (1998).
- No. 23 Klinkhamer PGL, de Jong TJ, Metz JAJ: *Sex and Size in Cosexual Plants*. IIASA Interim Report IR-97-078 (1997). Trends in Ecology and Evolution 12:260-265 (1997).
- No. 24 Fontana W, Schuster P: *Shaping Space: The Possible and the Attainable in RNA Genotype-Phenotype Mapping*. IIASA Interim Report IR-98-004 (1998). Journal of Theoretical Biology 194:491-515 (1998).
- No. 25 Kisdi É, Geritz SAH: *Adaptive Dynamics in Allele Space: Evolution of Genetic Polymorphism by Small Mutations in a Heterogeneous Environment*. IIASA Interim Report IR-98-038 (1998). Evolution 53:993-1008 (1999).
- No. 26 Fontana W, Schuster P: *Continuity in Evolution: On the Nature of Transitions*. IIASA Interim Report IR-98-039 (1998). Science 280:1451-1455 (1998).
- No. 27 Nowak MA, Sigmund K: *Evolution of Indirect Reciprocity by Image Scoring/ The Dynamics of Indirect Reciprocity*. IIASA Interim Report IR-98-040 (1998). Nature 393:573-577 (1998). Journal of Theoretical Biology 194:561-574 (1998).
- No. 28 Kisdi É: *Evolutionary Branching Under Asymmetric Competition*. IIASA Interim Report IR-98-045 (1998). Journal of Theoretical Biology 197:149-162 (1999).
- No. 29 Berger U: *Best Response Adaptation for Role Games*. IIASA Interim Report IR-98-086 (1998).
- No. 30 van Dooren TJM: *The Evolutionary Ecology of Dominance-Recessivity*. IIASA Interim Report IR-98-096 (1998). Journal of Theoretical Biology 198:519-532 (1999).
- No. 31 Dieckmann U, O'Hara B, Weisser W: *The Evolutionary Ecology of Dispersal*. IIASA Interim Report IR-98-108 (1998). Trends in Ecology and Evolution 14:88-90 (1999).
- No. 32 Sigmund K: *Complex Adaptive Systems and the Evolution of Reciprocation*. IIASA Interim Report IR-98-100 (1998). Ecosystems 1:444-448 (1998).
- No. 33 Posch M, Pichler A, Sigmund K: *The Efficiency of Adapting Aspiration Levels*. IIASA Interim Report IR-98-103 (1998). Proceedings of the Royal Society London Series B 266:1427-1435 (1999).
- No. 34 Mathias A, Kisdi É: *Evolutionary Branching and Coexistence of Germination Strategies*. IIASA Interim Report IR-99-014 (1999).
- No. 35 Dieckmann U, Doebeli M: *On the Origin of Species by Sympatric Speciation*. IIASA Interim Report IR-99-013 (1999). Nature 400:354-357 (1999).
- No. 36 Metz JAJ, Gyllenberg M: *How Should We Define Fitness in Structured Metapopulation Models? Including an Application to the Calculation of Evolutionarily Stable Dispersal Strategies*. IIASA Interim Report IR-99-019 (1999). Proceedings of the Royal Society of London Series B 268:499-508 (2001).
- No. 37 Gyllenberg M, Metz JAJ: *On Fitness in Structured Metapopulations*. IIASA Interim Report IR-99-037 (1999). Journal of Mathematical Biology 43:545-560 (2001).
- No. 38 Meszéna G, Metz JAJ: *Species Diversity and Population Regulation: The Importance of Environmental Feedback Dimensionality*. IIASA Interim Report IR-99-045 (1999).
- No. 39 Kisdi É, Geritz SAH: *Evolutionary Branching and Sympatric Speciation in Diploid Populations*. IIASA Interim Report IR-99-048 (1999).
- No. 40 Ylikarjula J, Heino M, Dieckmann U: *Ecology and Adaptation of Stunted Growth in Fish*. IIASA Interim Report IR-99-050 (1999). Evolutionary Ecology 13:433-453 (1999).
- No. 41 Nowak MA, Sigmund K: *Games on Grids*. IIASA Interim Report IR-99-038 (1999). Dieckmann U, Law R, Metz JAJ (eds): The Geometry of Ecological Interactions: Simplifying Spatial Complexity, Cambridge University Press, Cambridge, UK, pp. 135-150 (2000).
- No. 42 Ferrière R, Michod RE: *Wave Patterns in Spatial Games and the Evolution of Cooperation*. IIASA Interim Report IR-99-041 (1999). Dieckmann U, Law R, Metz JAJ (eds): The Geometry of Ecological Interactions: Simplifying Spatial Complexity, Cambridge University Press, Cambridge, UK, pp. 318-332 (2000).
- No. 43 Kisdi É, Jacobs FJA, Geritz SAH: *Red Queen Evolution by Cycles of Evolutionary Branching and Extinction*. IIASA Interim Report IR-00-030 (2000). Selection 2:161-176 (2001).
- No. 44 Meszéna G, Kisdi É, Dieckmann U, Geritz SAH, Metz JAJ: *Evolutionary Optimisation Models and Matrix Games in the Unified Perspective of Adaptive Dynamics*. IIASA Interim Report IR-00-039 (2000). Selection 2:193-210 (2001).
- No. 45 Parvinen K, Dieckmann U, Gyllenberg M, Metz JAJ: *Evolution of Dispersal in Metapopulations with Local Density Dependence and Demographic Stochasticity*. IIASA Interim Report IR-00-035 (2000). Journal of Evolutionary Biology 16:143-153 (2003).
- No. 46 Doebeli M, Dieckmann U: *Evolutionary Branching and Sympatric Speciation Caused by Different Types of Ecological Interactions*. IIASA Interim Report IR-00-040 (2000). The American Naturalist 156:S77-S101 (2000).
- No. 47 Heino M, Hanski I: *Evolution of Migration Rate in a Spatially Realistic Metapopulation Model*. IIASA Interim Report IR-00-044 (2000). The American Naturalist 157:495-511 (2001).
- No. 48 Gyllenberg M, Parvinen K, Dieckmann U: *Evolutionary Suicide and Evolution of Dispersal in Structured Metapopulations*. IIASA Interim Report IR-00-056 (2000). Journal of Mathematical Biology 45:79-105 (2002).
- No. 49 van Dooren TJM: *The Evolutionary Dynamics of Direct Phenotypic Overdominance: Emergence Possible, Loss Probable*. IIASA Interim Report IR-00-048 (2000). Evolution 54:1899-1914 (2000).
- No. 50 Nowak MA, Page KM, Sigmund K: *Fairness Versus Reason in the Ultimatum Game*. IIASA Interim Report IR-00-57 (2000). Science 289:1773-1775 (2000).
- No. 51 de Feo O, Ferrière R: *Bifurcation Analysis of Population Invasion: On-Off Intermittency and Basin Riddling*. IIASA Interim Report IR-00-074 (2000). International Journal of Bifurcation and Chaos 10:443-452 (2000).

- No. 52 Heino M, Laaka-Lindberg S: *Clonal Dynamics and Evolution of Dormancy in the Leafy Hepatic Lophozia Silvicola*. IIASA Interim Report IR-01-018 (2001). *Oikos* 94:525-532 (2001).
- No. 53 Sigmund K, Hauert C, Nowak MA: *Reward and Punishment in Minigames*. IIASA Interim Report IR-01-031 (2001). *Proceedings of the National Academy of Sciences of the USA* 98:10757-10762 (2001).
- No. 54 Hauert C, De Monte S, Sigmund K, Hofbauer J: *Oscillations in Optional Public Good Games*. IIASA Interim Report IR-01-036 (2001).
- No. 55 Ferrière R, Le Galliard J: *Invasion Fitness and Adaptive Dynamics in Spatial Population Models*. IIASA Interim Report IR-01-043 (2001). Clobert J, Dhondt A, Danchin E, Nichols J (eds): *Dispersal*, Oxford University Press, pp. 57-79 (2001).
- No. 56 de Mazancourt C, Loreau M, Dieckmann U: *Can the Evolution of Plant Defense Lead to Plant-Herbivore Mutualism*. IIASA Interim Report IR-01-053 (2001). *The American Naturalist* 158:109-123 (2001).
- No. 57 Claessen D, Dieckmann U: *Ontogenetic Niche Shifts and Evolutionary Branching in Size-Structured Populations*. IIASA Interim Report IR-01-056 (2001). *Evolutionary Ecology Research* 4:189-217 (2002).
- No. 58 Brandt H: *Correlation Analysis of Fitness Landscapes*. IIASA Interim Report IR-01-058 (2001).
- No. 59 Dieckmann U: *Adaptive Dynamics of Pathogen-Host Interactions*. IIASA Interim Report IR-02-007 (2002). Dieckmann U, Metz JAJ, Sabelis MW, Sigmund K (eds): *Adaptive Dynamics of Infectious Diseases: In Pursuit of Virulence Management*, Cambridge University Press, Cambridge, UK, pp. 39-59 (2002).
- No. 60 Nowak MA, Sigmund K: *Super- and Coinfection: The Two Extremes*. IIASA Interim Report IR-02-008 (2002). Dieckmann U, Metz JAJ, Sabelis MW, Sigmund K (eds): *Adaptive Dynamics of Infectious Diseases: In Pursuit of Virulence Management*, Cambridge University Press, Cambridge, UK, pp. 124-137 (2002).
- No. 61 Sabelis MW, Metz JAJ: *Taking Stock: Relating Theory to Experiment*. IIASA Interim Report IR-02-009 (2002). Dieckmann U, Metz JAJ, Sabelis MW, Sigmund K (eds): *Adaptive Dynamics of Infectious Diseases: In Pursuit of Virulence Management*, Cambridge University Press, Cambridge, UK, pp. 379-398 (2002).
- No. 62 Cheptou P, Dieckmann U: *The Evolution of Self-Fertilization in Density-Regulated Populations*. IIASA Interim Report IR-02-024 (2002). *Proceedings of the Royal Society of London Series B* 269:1177-1186 (2002).
- No. 63 Bürger R: *Additive Genetic Variation Under Intraspecific Competition and Stabilizing Selection: A Two-Locus Study*. IIASA Interim Report IR-02-013 (2002). *Theoretical Population Biology* 61:197-213 (2002).
- No. 64 Hauert C, De Monte S, Hofbauer J, Sigmund K: *Volunteering as Red Queen Mechanism for Co-operation in Public Goods Games*. IIASA Interim Report IR-02-041 (2002). *Science* 296:1129-1132 (2002).
- No. 65 Dercole F, Ferrière R, Rinaldi S: *Ecological Bistability and Evolutionary Reversals under Asymmetrical Competition*. IIASA Interim Report IR-02-053 (2002). *Evolution* 56:1081-1090 (2002).
- No. 66 Dercole F, Rinaldi S: *Evolution of Cannibalistic Traits: Scenarios Derived from Adaptive Dynamics*. IIASA Interim Report IR-02-054 (2002). *Theoretical Population Biology* 62:365-374 (2002).
- No. 67 Bürger R, Gimelfarb A: *Fluctuating Environments and the Role of Mutation in Maintaining Quantitative Genetic Variation*. IIASA Interim Report IR-02-058 (2002). *Genetical Research* 80:31-46 (2002).
- No. 68 Bürger R: *On a Genetic Model of Intraspecific Competition and Stabilizing Selection*. IIASA Interim Report IR-02-062 (2002). *Amer. Natur.* 160:661-682 (2002).
- No. 69 Doebeli M, Dieckmann U: *Speciation Along Environmental Gradients*. IIASA Interim Report IR-02-079 (2002). *Nature* 421:259-264 (2003).
- No. 70 Dercole F, Irisson J, Rinaldi S: *Bifurcation Analysis of a Prey-Predator Coevolution Model*. IIASA Interim Report IR-02-078 (2002). *SIAM Journal on Applied Mathematics* 63:1378-1391 (2003).
- No. 71 Le Galliard J, Ferrière R, Dieckmann U: *The Adaptive Dynamics of Altruism in Spatially Heterogeneous Populations*. IIASA Interim Report IR-03-006 (2003). *Evolution* 57:1-17 (2003).
- No. 72 Taborsky B, Dieckmann U, Heino M: *Unexpected Discontinuities in Life-History Evolution under Size-Dependent Mortality*. IIASA Interim Report IR-03-004 (2003). *Proceedings of the Royal Society of London Series B* 270:713-721 (2003).
- No. 73 Gardmark A, Dieckmann U, Lundberg P: *Life-History Evolution in Harvested Populations: The Role of Natural Predation*. IIASA Interim Report IR-03-008 (2003). *Evolutionary Ecology Research* 5:239-257 (2003).
- No. 74 Mizera F, Meszéna G: *Spatial Niche Packing, Character Displacement and Adaptive Speciation Along an Environmental Gradient*. IIASA Interim Report IR-03-062 (2003). *Evolutionary Ecology Research* 5:363-382 (2003).
- No. 75 Dercole F: *Remarks on Branching-Extinction Evolutionary Cycles*. IIASA Interim Report IR-03-077 (2003). *Journal of Mathematical Biology* 47:569-580 (2003).
- No. 76 Hofbauer J, Sigmund K: *Evolutionary Game Dynamics*. IIASA Interim Report IR-03-078 (2003). *Bulletin of the American Mathematical Society* 40:479-519 (2003).
- No. 77 Ernande B, Dieckmann U, Heino M: *Adaptive Changes in Harvested Populations: Plasticity and Evolution of Age and Size at Maturation*. IIASA Interim Report IR-03-058 (2003). *Proceedings of the Royal Society of London Series B-Biological Sciences* 271:415-423 (2004).
- No. 78 Hanski I, Heino M: *Metapopulation-Level Adaptation of Insect Host Plant Preference and Extinction-Colonization Dynamics in Heterogeneous Landscapes*. IIASA Interim Report IR-03-028 (2003). *Theoretical Population Biology* 63:309-338 (2003).
- No. 79 van Doorn G, Dieckmann U, Weissing FJ: *Sympatric Speciation by Sexual Selection: A Critical Re-Evaluation*. IIASA Interim Report IR-04-003 (2004). *American Naturalist* 163:709-725 (2004).
- No. 80 Egas M, Dieckmann U, Sabelis MW: *Evolution Restricts the Coexistence of Specialists and Generalists - the Role of Trade-off Structure*. IIASA Interim Report IR-04-004 (2004). *American Naturalist* 163:518-531 (2004).

- No. 81 Ernande B, Dieckmann U: *The Evolution of Phenotypic Plasticity in Spatially Structured Environments: Implications of Intraspecific Competition, Plasticity Costs, and Environmental Characteristics*. IIASA Interim Report IR-04-006 (2004). *Journal of Evolutionary Biology* 17:613-628 (2004).
- No. 82 Cressman R, Hofbauer J: *Measure Dynamics on a One-Dimensional Continuous Trait Space: Theoretical Foundations for Adaptive Dynamics*. IIASA Interim Report IR-04-016 (2004).
- No. 83 Cressman R: *Dynamic Stability of the Replicator Equation with Continuous Strategy Space*. IIASA Interim Report IR-04-017 (2004).
- No. 84 Ravnigné V, Olivieri I, Dieckmann U: *Implications of Habitat Choice for Protected Polymorphisms*. IIASA Interim Report IR-04-005 (2004). *Evolutionary Ecology Research* 6:125-145 (2004).
- No. 85 Nowak MA, Sigmund K: *Evolutionary Dynamics of Biological Games*. IIASA Interim Report IR-04-013 (2004). *Science* 303:793-799 (2004).
- No. 86 Vukics A, Asbóth J, Meszéna G: *Speciation in Multidimensional Evolutionary Space*. IIASA Interim Report IR-04-028 (2004). *Physical Review* 68:041-903 (2003).
- No. 87 de Mazancourt C, Dieckmann U: *Trade-off Geometries and Frequency-dependent Selection*. IIASA Interim Report IR-04-039 (2004). *American Naturalist* 164:765-778 (2004).
- No. 88 Cadet CR, Metz JAJ, Klinkhamer PGL: *Size and the Not-So-Single Sex: disentangling the effects of size on sex allocation*. IIASA Interim Report IR-04-084 (2004). *American Naturalist* 164:779-792 (2004).
- No. 89 Rueffler C, van Dooren TJM, Metz JAJ: *Adaptive Walks on Changing Landscapes: Levins' Approach Extended*. IIASA Interim Report IR-04-083 (2004). *Theoretical Population Biology* 65:165-178 (2004).
- No. 90 de Mazancourt C, Loreau M, Dieckmann U: *Understanding Mutualism When There is Adaptation to the Partner*. IIASA Interim Report IR-05-016 (2005). *Journal of Ecology* 93:305-314 (2005).
- No. 91 Dieckmann U, Doebeli M: *Pluralism in Evolutionary Theory*. IIASA Interim Report IR-05-017 (2005). *Journal of Evolutionary Biology* 18:1209-1213 (2005).
- No. 92 Doebeli M, Dieckmann U, Metz JAJ, Tautz D: *What We Have Also Learned*. IIASA Interim Report IR-05-018 (2005). *Evolution* 59:691-695 (2005).
- No. 93 Egas M, Sabelis MW, Dieckmann U: *Evolution of Specialization and Ecological Character Displacement of Herbivores Along a Gradient of Plant Quality*. IIASA Interim Report IR-05-019 (2005). *Evolution* 59:507-520 (2005).
- No. 94 Le Galliard J, Ferrière R, Dieckmann U: *Adaptive Evolution of Social Traits: Origin, Trajectories, and Correlations of Altruism and Mobility*. IIASA Interim Report IR-05-020 (2005). *American Naturalist* 165:206-224 (2005).
- No. 95 Doebeli M, Dieckmann U: *Adaptive Dynamics as a Mathematical Tool for Studying the Ecology of Speciation Processes*. IIASA Interim Report IR-05-022 (2005). *Journal of Evolutionary Biology* 18:1194-1200 (2005).
- No. 96 Brandt H, Sigmund K: *The Logic of Reprobation: Assessment and Action Rules for Indirect Reciprocity*. IIASA Interim Report IR-04-085 (2004). *Journal of Theoretical Biology* 231:475-486 (2004).
- No. 97 Hauert C, Haiden N, Sigmund K: *The Dynamics of Public Goods*. IIASA Interim Report IR-04-086 (2004). *Discrete and Continuous Dynamical Systems - Series B* 4:575-587 (2004).
- No. 98 Meszéna G, Gyllenberg M, Jacobs FJA, Metz JAJ: *Link Between Population Dynamics and Dynamics of Darwinian Evolution*. IIASA Interim Report IR-05-026 (2005). *Physical Review Letters* 95:Article 078105 (2005).
- No. 99 Meszéna G: *Adaptive Dynamics: The Continuity Argument*. IIASA Interim Report IR-05-032 (2005). *Journal of Evolutionary Biology* 18:1182-1185 (2005).
- No. 100 Brännström NA, Dieckmann U: *Evolutionary Dynamics of Altruism and Cheating Among Social Amoebas*. IIASA Interim Report IR-05-039 (2005). *Proceedings of the Royal Society London Series B* 272:1609-1616 (2005).
- No. 101 Meszéna G, Gyllenberg M, Pasztor L, Metz JAJ: *Competitive Exclusion and Limiting Similarity: A Unified Theory*. IIASA Interim Report IR-05-040 (2005).
- No. 102 Szabo P, Meszéna G: *Limiting Similarity Revisited*. IIASA Interim Report IR-05-050 (2005).
- No. 103 Krakauer DC, Sasaki A: *The Greater than Two-Fold Cost of Integration for Retroviruses*. IIASA Interim Report IR-05-069 (2005).
- No. 104 Metz JAJ: *Eight Personal Rules for Doing Science*. IIASA Interim Report IR-05-069 (2005). *Journal of Evolutionary Biology* 18:1178-1181 (2005).
- No. 105 Beltman JB, Metz JAJ: *Speciation: More Likely Through a Genetic or Through a Learned Habitat Preference?* IIASA Interim Report IR-05-072 (2005). *Proceedings of the Royal Society of London Series B* 272:1455-1463 (2005).

Issues of the IIASA Studies in Adaptive Dynamics series can be obtained at www.iiasa.ac.at/Research/ADN/Series.html or by writing to adn@iiasa.ac.at.

Contents

Summary.....	2
Introduction	3
Model description	5
Habitat preference.....	6
Habitat-dependent viability	7
Recurrence equations.....	7
Adaptive-dynamical analysis.....	8
Individual-based simulations	8
Results	10
Discussion.....	14
Acknowledgements	17
References	17
Table and Figure Legends	22
Table	23
Figures	24
 Appendix	
The selection gradient.....	1
Specialists with a genetic preference for their optimal habitat.....	2
Generalists without a habitat preference	4
References	6

Speciation: more likely through a genetic or through a learned habitat preference?

J. B. Beltman^{*,†,‡} and J. A. J. Metz ^{*,‡,§}

*Section Theoretical Biology

†Section Behavioural Biology

‡Institute of Biology, Leiden University
Van der Klaauw Laboratory, Kaiserstraat 63, 2311 GP Leiden, The Netherlands

§ Adaptive Dynamics Network, IIASA, A-2361 Laxenburg, Austria

Corresponding author: J.A.J. Metz

Phone: +31-71-5274937

Fax: +31-71-5274900

E-mail: metz@rulsfb.leidenuniv.nl

Word count: approximately 7800 words

Summary

A problem in understanding sympatric speciation is establishing how reproductive isolation can arise when there is disruptive selection on an ecological trait. One of the solutions that has been proposed is that a habitat preference evolves, and that mates are chosen within the preferred habitat. We present a model where the habitat preference can evolve either by means of a genetic mechanism or by means of learning. Employing an adaptive-dynamical analysis, we show that evolution proceeds either to a single population of specialists with a genetic preference for their optimal habitat, or to a population of generalists without a habitat preference. The generalist population subsequently experiences disruptive selection. Learning promotes speciation because it increases the intensity of disruptive selection. An individual-based version of the model shows that, when loci are completely unlinked and learning confers little cost, the presence of disruptive selection most likely leads to speciation via the simultaneous evolution of a learned habitat preference. For high costs of learning, speciation is most likely to occur via the evolution of a genetic habitat preference. However, the latter only happens when the effect of mutations is large, or when there is linkage between genes coding for the different traits. **Keywords:** speciation; habitat preference; learning; disruptive selection; adaptive dynamics

Introduction

Unravelling the processes that underly the evolution of new species is one of the major themes of evolutionary biology. Research has especially been focussed on the role of geographical separation in speciation. However, despite decades of empirical and theoretical research, consensus on the likelihood of speciation in the face of geneflow has not been reached (Turelli *et al.* 2001; Via 2001; Kirkpatrick & Ravigné 2002; Coyne & Orr 2004; Gavrillets 2004). When a population experiences disruptive selection on an ecological trait, random mating will normally prevent the population from splitting into two species. Hence, a problem in understanding of sympatric speciation is establishing how assortative mating can evolve under such a regime of disruptive selection. One of the possible solutions that has been put forward is related to the availability of two different habitats or hosts. When disruptive selection favors ecological specialization on two different habitats, the evolution of habitat choice may aid sympatric speciation if prezygotic isolation is a by-product of divergent habitat selection. Several theoretical studies have demonstrated that this is a plausible speciation mechanism (Rice 1984; Diehl & Bush 1989; Johnson *et al.* 1996; Kawecki 1996, 1997; Fry 2003; Gavrillets 2004).

In these speciation models incorporating habitat choice, it is generally assumed that the preference for one of the habitats is a genetically determined trait. Typically, each preference allele shifts the preference in the direction of one of the habitats. We refer to this mechanism as a “genetic habitat preference”, although there are other ways to model a genetically based preference (see e.g. Kawecki 1996, 1997). A possibility that has received less attention is that individuals may develop a preference for the habitat they have experienced at a young age. Such a learned preference for habitat or host features is known to occur in several groups of animal species, including birds, fish, and insects. Several examples are mentioned in West-Eberhard (2003); Beltman *et al.* (2004), but the most extensive review to date is provided by Davis & Stamps (2004), who refer to this phenomenon as “natal habitat preference induction”. They suggest that it has been understudied, in part because scientists working with different taxa have used different terms to describe it (e.g., Hopkins’ host selection principle, habitat imprinting, or habitat conditioning). We will refer to it as a “learned habitat preference”, to highlight the resemblance as well as the difference with a genetic habitat preference.

Several authors have discussed the possible importance of a learned habitat preference in speciation (e.g., Thorpe 1945; Maynard Smith 1966; Rice 1984; Kondrashov & Mina 1986; West-Eberhard 2003): Just as in the

case of a genetic preference, the learned habitat preference may (i) cause assortative mating between individuals that prefer the same habitat, and (ii) cause individuals to produce their young in the habitat type they experienced themselves at a young age. As a result, a learned habitat preference may assist speciation because individuals exploiting a new, previously unused habitat, may very quickly be reproductively isolated from the original population. However, it has also been stated that this effect is not large enough to play a significant role (Mayr 1947).

Recently, theoretical studies have shown that speciation through a learned habitat preference is extremely effective (Beltman *et al.* 2004; Beltman & Haccou 2005). In these previous theoretical analyses it was assumed that the learning of habitat features was already present from the onset of speciation. Thus, the question whether the learning of habitat features can evolve from scratch as a consequence of disruptive selection on an ecological trait could not be answered. Still, this seems likely, because it was found that as soon as there is divergence in an ecological trait, there is selection on reinforcement of the effect that learning has on assortative mating and on the location where young are produced (Beltman & Haccou 2005). Hence, these effects of learning are expected to become stronger and stronger, which goes against the prediction of Mayr (1947) that a learned habitat preference is unimportant.

Speciation through the evolution of a learned habitat preference is an effective mechanism because it is a one-allele mechanism (Felsenstein 1981). That is, alleles that strengthen (the effects of) learning necessarily have the same effect in both habitats. In contrast, speciation through the evolution of a genetic habitat preference is a two-allele mechanism (at least, in our definition of a genetic preference). Hence, alleles that modify the genetic habitat preference always shift the preference in the same direction. Interestingly, the way we model the evolution of a learned habitat preference can alternatively be interpreted as a model of migration modification. It has been shown that modifiers of migration are expected to reduce migration between two populations to zero (Balkau & Feldman 1973; Karlin & McGregor 1974; Gillespie 1981; Wiener & Feldman 1991, 1993), which is in essence the same as the strengthening of a learned habitat preference. (Note, however, that this effect can be modified by kin competition and environmental stochasticity (Kisdi 2002; Leturque & Rousset 2002; S. & Lenormand 2005).)

In summary, when studied in separate models, both a genetic and a learned habitat preference have appeared quite likely to evolve. It is interesting to consider what would happen when both possibilities evolve at the same time. Clearly, the evolution of a learned habitat preference has

the advantage of being a one-allele mechanism. Hence, during its evolution recombination does not destroy associations between alleles that strengthen learning and ecological adaptation alleles, whereas this is a problem in the case of a genetic preference. However, the intensity of selection on the genetic habitat preference is expected to be stronger than selection on the learned habitat preference. This can be understood by considering offspring that are accidentally produced in the “wrong” habitat. When their habitat preference is genetically determined, they are more likely to produce their own young in the “correct” habitat, thus repairing their parents’ mistakes, than when they learn their habitat preference.

In this paper, we construct a speciation model incorporating both a genetic and a learned habitat preference. Our aims are to investigate under which circumstances speciation occurs, and via which of the two preference mechanisms this is most likely. First, using adaptive dynamics (Metz *et al.* 1996; Dieckmann & Law 1996; Geritz *et al.* 1998; Leimar 2001, 2005), we study the simultaneous evolution of an ecological trait, and of two traits determining respectively the genetic and learned habitat preference of individuals. For simplicity, we assume that habitat choice influences solely the location where young are produced, and do not take into account the effect on assortative mating. This allows us to study when evolution of the three traits leads to disruptive selection, which facilitates speciation (e.g., Kawecki 1996, 1997; Dieckmann & Doebeli 1999). Our results show that the presence of learning leads to a higher intensity of disruptive selection, thus promoting speciation. To examine whether speciation indeed follows the presence of disruptive selection, we extend the analysis employing an individual-based model where it is in addition assumed that mate choice occurs in the preferred habitat. It appears that speciation more readily occurs through a learned than through a genetic habitat preference when there is free recombination and when the cost of learning is low. In that case speciation through a genetic preference is only possible when the traits are coded by a few, and therefore major, loci. When there is linkage between genes that code for specialization and those that code for a genetic habitat preference, speciation through a genetic preference becomes more likely than for free recombination.

Model description

We consider a population of individuals that exploit two habitats, A and B . This could for example represent a population of phytophagous insects feeding on two different host plant species. Two variants of the model are

examined: one uses the framework of adaptive dynamics (Metz *et al.* 1996; Dieckmann & Law 1996; Geritz *et al.* 1998; Leimar 2001, 2005) to predict the course of evolution; the other is an individual-based model. In both cases individuals have three traits, two of which affect their habitat-selection behavior (referred to as genetic habitat preference, and learning ability), and one that determines the viability of individuals when born in either of the two habitats (referred to as specialization coefficient).

Habitat preference

The genetic habitat preference, g , is a baseline preference that individuals would express when experience does not affect habitat choice. Biologically relevant values of g can range from 0 (absolute preference for habitat A) through 0.5 (no preference) to 1 (absolute preference for habitat B). The habitat preference resulting from g can be modified by the learning of features of the habitat that is experienced early in life. The learning ability is the extent to which the genetic habitat preference is modified by experience. An individual with $l = 0$ does not learn and hence its habitat preference exactly equals its genetic habitat preference. For $0 < l \leq 1$ the habitat preference shifts toward the habitat that was experienced early in life. For $l = 1$ the genetic habitat preference is completely overruled by learning. Note that the extent of preference modification is genetically determined, but the direction of preference change depends on early experience and can thus be either in the same or in the opposite direction as the genetic preference.

We assume that the resulting habitat preference—an interplay between the genetic habitat preference and learning ability—determines the habitat that is chosen for reproduction. Specifically, an individual that is born in habitat x chooses habitat y for reproduction with probability f_{xy} , where f_{xy} is a function of g , l and the location of birth as in Table 1.

In our adaptive-dynamical analysis (see below), the habitat preference is assumed to influence the location where young are produced: females born in habitat x produce their young with probability f_{xy} in habitat y . In the individual-based version of the model, habitat preference in addition affects mate choice in the sense that individuals with a preference for the same habitat are most likely to mate with each other because the probability that they encounter each other at the time of reproduction is large. Matings between individuals that prefer different habitats occur as long as the habitat preference of all individuals is not absolute.

Habitat-dependent viability

Apart from the genetic habitat preference g and the learning ability l , there is a third trait, the specialization coefficient, a (from adaptedness), that determines the viability when born in the different habitats (rendering a similar underlying ecological framework as in Geritz *et al.* 1998; Geritz & Kisdi 2000). Individuals with $a = a_A$ are most viable when born in habitat A (specialists on A), and those with $a = a_B$ are most viable when born in habitat B (specialists on B). Individuals with $a = (a_A + a_B)/2$ are equally well adapted to both habitats (generalists). The viability changes according to a Gaussian function with scale parameter σ^2 when the specialization coefficient is away from the optimum. The parameter σ^2 determines the trade-off between viabilities in habitat A and B . This is in part caused by how much the habitats differ from each other, and in part by the genetic architecture of the species. Specifically, the viability of an individual with specialization coefficient a that is born in habitat x equals

$$w_x(a) = e^{-(a-a_x)^2/(2\sigma^2)} \quad . \quad (1)$$

Recurrence equations

To derive the recurrence equations, we need to keep track of two types of individuals, namely those born in habitat A and those born in habitat B . The density of these types is denoted by N_A and N_B respectively. To derive equations for these densities at the next timestep (denoted by N'_A and N'_B), we need to know the density of young produced in each habitat, and the fraction of these young that survive viability selection and competition for resources. Each individual produces on average E young. These young are produced partly in habitat A and partly in habitat B , depending on the individual's habitat preference (see Table 1). A certain fraction of these young survives viability selection according to Equation (1). Additionally, we assume that there is a cost of learning, c , for instance because brain nuclei involved in the learning process need to develop. Higher learning abilities therefore imply that the viability is decreased by a factor $(1 - cl)$. The density of young after viability selection in habitat x , Y_x , is then given by:

$$Y_x(g, l, a) = w_x(a)E(1 - cl)(f_{Ax}(g, l)N_A(g, l, a) + f_{Bx}(g, l)N_B(g, l, a)) \quad (2)$$

Finally, after viability selection these individuals compete with others that are born in the same habitat. We model this process using Beverton-Holt

type density dependence, where K is a parameter determining the population densities at equilibrium. Both habitats are assumed to be able to sustain an equal population density at equilibrium. These assumptions yield the following recurrence equations for the density of individuals in the next generation:

$$N'_x(g, l, a) = Y_x(g, l, a)/(1 + Y_x(g, l, a)/K) \quad . \quad (3)$$

Adaptive-dynamical analysis

For the first stage of the analysis we use the framework of adaptive dynamics (Metz *et al.* 1996; Dieckmann & Law 1996; Geritz *et al.* 1998; Leimar 2001, 2005). In this framework, it is assumed that mutations occur rarely and that they lead to small changes in the phenotypic values of individuals. For simplicity, the initial population is assumed to be monomorphic (i.e., consist of identical individuals). This allows one to predict the direction of evolution by calculating the intensity of selection on the evolving traits. As long as the intensity of selection on the traits is nonzero, this will result in directional evolution (Dieckmann & Law 1996). Such evolution comes to a halt in so-called evolutionarily singular points, in which the intensity of directional selection is zero. To calculate the selection gradient, which is a vector containing the intensities of selection on each of the evolving traits, mutants are assumed to appear after the residents have attained population dynamical equilibrium. The residents present at equilibrium and their densities influence the selection gradient, because the residents constitute the ecological environment of mutants. The detailed adaptive-dynamical analysis is given in the Electronic Appendix.

Individual-based simulations

In our adaptive-dynamical analysis the effect of habitat preference on mate choice is not taken into account. For directional evolution this does not influence the course of evolution when there is no heterozygote advantage (e.g., Kisdi & Geritz 1999; Geritz & Kisdi 2000; van Dooren 2005; Metz 2005). However, as soon as the population becomes polymorphic as a result of disruptive selection, mate choice should be taken into account to study further evolutionary changes. Therefore, we follow the evolutionary dynamics of g , l , and a employing individual-based simulations (C program available on request). Speciation occurs when the population comes to

consist of two types of specialists that have an “absolute” preference (genetically determined or learned) for the habitat in which they are born.

The specialization coefficient, the genetic habitat preference and the learning ability are encoded by k_a , k_g and k_l diploid loci respectively. Alleles are either \oplus or \ominus , and they act additively to determine the trait values of an individual. When an individual has i \oplus alleles at the loci coding for that trait, it has a trait value of $(k_t + (i - k_t)\phi)/(2k_t)$, where k_t is the number of loci coding for the trait, and ϕ determines how large the effect of a mutation is. Hence, for individuals with only \ominus alleles the trait value reaches its minimal value, and increasing the number of \oplus alleles raises the trait value in a linear fashion to its maximum value. When the resulting trait value exceeds the range of biologically realistic values (as can be the case for g and l which can vary from 0 to 1), it is rounded off to its nearest extreme. Hence, although it is possible that individuals possess an excess habitat preference, this is not expressed.

In the simulations we assume that the viability optima in habitat A and B are 0 and 1 respectively (i.e., $a_A = 0$ and $a_B = 1$). The initial population consists of males and females with $a = 0$, $g = 0.5$, and $l = 0$, that is, all individuals are specialized on habitat A but have no habitat preference. To avoid the artificial incorporation of unrealistic amounts of initial variation, at the start of the simulations all individuals are exact copies of one another. For example, half of the g loci are initially fixed for the \oplus allele, and the other half for the \ominus allele (note that we use an even number of loci to achieve this).

Only newborns that survive viability selection and density regulation have a chance to reproduce. To establish mate choice, all individuals are first distributed across the habitats according to their habitat preference. Subsequently, each female randomly chooses a mate from the population of males present in her habitat, and produces young in one of the habitats, again chosen according to her habitat preference.

At each locus, newborns inherit one allele from their mother, and one from their father. We use three different schemes for the physical linkage between loci. In the first scheme (“no linkage”) we assume that there is free recombination. In the other two schemes some loci are physically linked, and we assume that this prevents recombination between them completely. Hence, the recombination rate between loci is assumed to be either 0 or 0.5: for simplicity we do not incorporate crossing over, and only take into account recombination that is due to the random distribution of male and female alleles that are on different chromosomes. To determine which loci are linked, individuals are assumed to contain k_c chromosomes,

and each locus is assigned one of the chromosomes. During one simulation the distribution of the loci over the chromosomes remains the same; in a subsequent simulation the distribution is chosen anew. In the second scheme the loci are evenly distributed over the chromosomes, which procedure is performed separately for each of the three traits (“predetermined linkage”). In the third scheme (“random linkage”), the distribution of all loci over the chromosomes is random. In both “predetermined linkage” and “random linkage” a value of $k_c = 1$ represents maximal linkage, because all loci are on the same chromosome. The degree of linkage decreases as k_c becomes larger. At very large k_c , all loci are on different chromosomes, which is represented by the “no linkage” scheme. The three linkage schemes thus are a simple way to implement different degrees of linkage, ranging from maximal linkage to completely unlinked.

Newborns can have mutations at the loci that code for g , l , and a . Each allele has a mutation probability of 0.0001. A mutation means that the particular allele is modified from a \oplus allele into a \ominus allele, or vice versa.

Results

The main aim of our adaptive-dynamical analysis is to study at which points there is no longer directional evolution of g , l , and a . Such evolutionarily singular points have two properties that determine how evolution will proceed (Metz *et al.* 1996; Geritz *et al.* 1998). First, the convergence stability property determines whether the singular point will be approached or not (Eshel 1983; Eshel & Motro 1981; Christiansen 1991). Second, the evolutionary stability property determines whether nearby mutants can invade or not when the singular point has been attained (Maynard Smith 1982). In the following we summarize the results of our analysis (details are provided in the Electronic Appendix).

The following potentially attracting singular points were found: (i) points where the population consists of a single specialist species with a genetic preference for its optimal habitat (i.e., either $a = a_A$, $g = 0$ and $l = 0$, or $a = a_B$, $g = 1$ and $l = 0$), and (ii) the point where the population consists of generalists without habitat preference (i.e., $a = (a_A + a_B)/2$, $g = 0.5$ and $l = 0$). The convergence stability of these points, and hence the evolutionary dynamics, depend in large part on σ^2 . For low σ^2 , evolution always proceeds to a single population of specialists with a genetic preference for their optimal habitat (figure 1a). For high σ^2 , directional evolution leads to a population of generalists without (genetic) habitat

preference (figure 1c). When σ^2 is intermediate, both types of singular points are convergence stable. Directional evolution then leads to one of them, but which one is attained depends on the initial trait values and the details of the mutation process (figure 1b).

There is one other possible end point of evolution, namely when the learning ability evolves to a value of one (trajectories leading to $l = 1$ are omitted from figure 1). In that case, the population splits immediately into two separate subpopulations that no longer interact (each exploiting a different habitat), after which in each of the subpopulations evolution proceeds to local specialists. Hence, this is a third possible outcome of evolution. However, a closer look at the intensity of selection on the evolving traits reveals that the intensity of selection on l is much lower than on g and a , even when there is no cost of learning. This can be understood by considering for instance individuals that are better adapted to habitat A than to habitat B . Clearly, they will have most surviving offspring if they have a preference for habitat A . However, a part of the offspring will still end up in habitat B , to which they are poorly adapted. When these young survive despite their poor adaptedness, they would do best by producing their offspring in habitat A , the habitat they did not grow up in. This is achieved only when they have a genetic habitat preference; in case of a learned habitat preference most young would be produced in the “wrong” habitat. When only directional evolution is considered, a habitat preference is thus more likely to evolve through a genetic mechanism than through learning. This is confirmed by numerical calculations of trajectories that follow the selection gradient (not shown) and by the individual-based simulations (see below). Hence, unless (i) the learning ability is initially already high, (ii) mutations in l are much more likely than mutations in the other traits, or (iii) there exist strong genetic correlations between l and one of the other traits, it seems unlikely that directional evolution will lead to $l = 1$.

We cannot exclude that, apart from the discussed evolutionarily singular points, there exist others that are under some circumstances attractors of directional evolution. However, numerical calculations of trajectories through trait space, and the individual-based simulations did not reveal the existence of additional attracting singular points. Hence, we conclude that directional evolution will normally lead either to a population of specialists with a genetic preference for their optimal habitat, or to a population of generalists without habitat preference. Such attractors of directional evolution are not necessarily the final endpoints of evolution, because when a singular point is not evolutionarily stable, the population will experience disruptive selection. In that case, speciation may occur when additionally assortative mating evolves; this is one possible way to escape from the

fitness minimum that keeps the population trapped at an evolutionarily unstable singular point. The singular point that represents a population of specialists is always evolutionarily stable. In contrast, the generalist population will under all circumstances experience disruptive selection. The intensity of this disruptive selection becomes higher as σ^2 decreases, and as the learning ability increases. Hence, learning promotes speciation.

Whether selection that favors the evolution of two extreme types will indeed lead to speciation depends on the one hand on the intensity of the disruptive force, and on the other hand on processes that oppose speciation such as random mate choice and recombination. Therefore, to study whether speciation can take place as soon as there is disruptive selection, mate choice should be taken into account. Our particular interest here is whether, given the availability of both options, this is more likely to occur via the evolution of a learned or genetic habitat preference. Using individual-based simulations, we examined the course of evolution of the specialization coefficient, genetic habitat preference and learning ability, starting from a population where all individuals specialize on habitat A ($a = 0$) but have no preference for either of the habitats ($g = 0.5$ and $l = 0$). As predicted by the adaptive-dynamical analysis, evolution first proceeded to either a population of specialists with a genetic habitat preference for their optimal habitat (figure 2a), or to a population of generalists without habitat preference (figure 2b-f). Both situations can be the end point of evolution (figure 2a-b), which means that in the latter case the forces that oppose speciation are stronger than the intensity of disruptive selection. Alternatively, disruptive selection experienced by the generalist population can lead to speciation (figure 2c-e). In that case the population splits in two groups specialized on and preferring either habitat A or habitat B . This habitat preference can be genetically determined in both groups (figure 2c), learned in both groups (figure 2d), or genetically determined in one group and learned in the other group (figure 2e). Another possible simulation outcome is that a clear polymorphism in g and a evolves, but speciation is not completed or not “stable” (e.g., figure 2f). (A similar result was found by (Matessi *et al.* 2002) for a generic one-allele mechanism.) In the following we investigate the circumstances for which each of the evolutionary end results is most likely.

As predicted by the adaptive-dynamical analysis, when σ^2 is low, evolution led to a population of specialists on habitat A that prefer that habitat (figure 3). For high values of σ^2 , evolution proceeded to a population of generalists (figure 3). At intermediate values of σ^2 , both the generalist and the specialist singular points are convergence stable. Hence, only in that case the initial conditions are expected to influence the results (e.g., starting closer to the generalist point will increase the likelihood of

evolving to that point). We also know from the adaptive-dynamical analysis that the generalist population experiences disruptive selection, the intensity of which decreases as σ^2 becomes higher. For free recombination and low costs of learning, disruptive selection indeed usually led to speciation. In that case speciation always occurred through a learned habitat preference (figure 3a). For high costs of learning, the selective force acting against the evolution of learning is too strong; speciation then is possible only through a genetic habitat preference. This happened when few loci coded for each trait (figure 3a). Otherwise, speciation through a genetic habitat preference did not take place, but the end result was a generalist species. This is because recombination is constantly destroying associations between alleles for specialization on one of the habitats and alleles that confer a genetic preference for that same habitat. This can only be overcome when the number of loci coding for the different traits is small. Mutations are then of large effect, thus increasing the fitness of more extreme individuals in comparison with the case where many loci code for the traits.

To see whether it was indeed recombination that obstructs speciation for intermediate values of σ^2 , we performed additional simulations using the linkage schemes in which some loci are physically linked. Because in these schemes loci are assumed to reside on a limited number of chromosomes (k_c), recombination occurs less often. As expected, increasing the physical linkage between loci made it more likely that speciation occurred through a genetic habitat preference or through a combination of genetic and learned habitat preference instead of through a learned habitat preference (figure 3b).

The results shown in figure 3 are based on a single run per parameter combination. We preferred to take small steps in parameter space and performing single runs, over taking large steps which would allow us to perform several runs per parameter combination. Our approach allows a good estimate of the resulting patterns, which are indeed very clear. In addition, we have investigated the robustness of the results by changing the values of E , the number of young produced per female, of K , which affects the size of the population at equilibrium, and of ϕ , which influences how large the effect of a mutation is, as well as the usage of “random linkage” instead of “predetermined linkage”. All these modifications did not render qualitatively different results with respect to whether speciation was more likely to occur through a genetic or through a learned habitat preference. However, some of these changes affected the likelihood of speciation, e.g., at large E speciation occurred more often than at low E . This can be explained with the aid of the adaptive-dynamical analysis: when E is high, the singular point consisting of generalists becomes attracting already at

lower σ^2 than when E is low (see the Electronic Appendix). Because at low σ^2 the intensity of disruptive selection is higher than at high σ^2 , speciation is indeed expected more often at high E than at low E .

Discussion

We examined the process of speciation by means of specialization on two different habitats under the assumption that both mating and the production of young occur in the preferred habitat. Our analysis shows that the outcome of evolution depends for a large part on the parameter σ^2 , which determines the trade-off between viabilities in the two habitats. A variety of related models have predicted that weak trade-offs (high σ^2) favor the evolution of generalists, while strong trade-offs (low σ^2) lead more easily to the evolution of specialists (e.g., Egas *et al.* 2004a; Rueffler *et al.* 2004). Our results are in line with this: Evolution proceeds either to a population where individuals specialize on one of the habitats and have a genetic preference for that habitat (for low σ^2), or to a population of generalists that have no genetic habitat preference (for high σ^2). The generalist population subsequently experiences disruptive selection, which can lead to speciation. We found that the intensity of disruptive selection is higher at high learning abilities than at low learning abilities, which means that learning promotes speciation.

Employing an individual-based version of the model, it was shown that, when loci are completely unlinked and learning confers only little cost, the presence of disruptive selection often leads to speciation through a learned habitat preference. As expected, high costs of learning prevent the evolution of a learned habitat preference. Instead, speciation then occurs through a genetic habitat preference, but only when the number of loci coding for the traits is small. Mutations are in that case of large effect. As a result, recombination between loci coding for adaptation to the habitats and loci coding for a genetic habitat preference, which counteracts speciation, can be overcome. For large numbers of loci this is not true: a generalist is then the end result of evolution because the force of recombination is too strong for speciation to take place. This is confirmed by simulations in which we incorporated physical linkage between loci, thus decreasing the amount of recombination counteracting speciation. In that case speciation through a genetic habitat preference more readily occurs than in the case of completely unlinked loci.

Speciation through a learned habitat preference is not hindered by

recombination, because it represents a one-allele mechanism in the sense of (Felsenstein 1981). Our results demonstrate that this advantage of a learned habitat preference is decisive when it competes with a genetic habitat preference, even though the intensity of selection on the learning ability is lower than that on the genetic habitat preference (figure 1). One can imagine other mechanisms of genetically determined habitat preference that represent a one-allele mechanism (see e.g., Kawecki 1996, 1997). An example of this are alleles that reduce migration between two populations (as in Balkau & Feldman 1973; Karlin & McGregor 1974). In fact, the way we modelled the learning ability can alternatively be interpreted as such a model of migration modification. The two particular mechanisms of development of habitat preference of this paper were chosen because these had already been studied in separation, but had not been incorporated in a single model. It would be interesting to extend the analysis by looking at refinements, and possible alternative implementations, of these habitat choice mechanisms.

Similar models studying the possibility of speciation through the evolution of a genetic habitat preference have concluded that such speciation occurred easily (e.g., Rice 1984; Diehl & Bush 1989; Johnson *et al.* 1996; Kawecki 1996, 1997; Fry 2003; Gavrillets 2004). This was found even when multiple, completely unlinked, loci code for the evolving traits. How do these results relate to our finding that recombination is a large obstacle to speciation, apparently preventing speciation more often than in the other models? Probably the most important reason for this is that the other studies went for very strong diversifying selection. For instance, one of these models was used to specifically search the intensity of diversifying selection on the ecological trait needed to overcome the recombination barrier (Fry 2003). In our model, the intensity of disruptive selection is higher when σ^2 is small than when σ^2 is large. However, small σ^2 also favors the evolution of a single specialist on one of the habitats. This happens because in our model the disruptive selection emerges at the level of the total population as a result of a heterogeneity in the selection in different subpopulations. In contrast, in other models that incorporate habitat preference the diversifying selection pressure is assumed a priori. Therefore, the option of evolving a single specialist is excluded by these models, which probably explains the difference in results.

We assumed that the learning of habitat features is costly, for example because brain structures that enable learning need to develop, giving those individuals with a high learning ability a competitive disadvantage in comparison with individuals with a low learning ability (e.g., see Johnston 1982; Dukas 1999). To estimate such a cost of learning is a difficult task (for an attempt see Mery & Kawecki 2003). By incorporating learning

costs we studied a kind of worst-case scenario for the evolution of a learned habitat preference. First, it could be argued just as well that exhibiting a genetic habitat preference is costly. Second, apart from being costly, learning could also confer an additional selective advantage: Here, we assumed that the only advantage of habitat choice is that it may give a large survival probability to the offspring of an individual with high learning ability. However, adaptive learning of habitat choice is often also advantageous in an individual's own lifetime (Johnston 1982; Papaj & Prokopy 1989; Bernays 1998; Egas & Sabelis 2001). Such learning is thought to evolve easiest in environments that are unpredictable in space and time (Stephens 1991, 1993). It might then be employed in the manner envisaged in our model, thus not only increasing the survival probability of the individual itself, but also of its offspring.

Our results suggest that when speciation occurs via the simultaneous evolution of a habitat preference, it is likely that this happens either through a learned habitat preference, or that genes coding for ecological adaptation and those coding for genetic habitat preference are tightly linked. Interestingly, in a case where early experience is known not to influence habitat preference (Via 1991), genes for habitat choice and ecological adaptation indeed appeared to reside close together on the same chromosome (Hawthorne & Via 2001) or possibly even are one and the same gene (Coyne & Orr 2004). This calls for more studies examining on the one hand the presence of such physical linkage, and on the other hand in what manner experience influences habitat choice.

Several researchers have mentioned the possible importance of a learned habitat preference in speciation (e.g., Thorpe 1945; Maynard Smith 1966; Rice 1984; Kondrashov & Mina 1986; West-Eberhard 2003). In contrast, Mayr (1947) stated that it would not be strong enough to play a significant role. However, our analysis shows that a learned habitat preference is likely to evolve when there is disruptive selection (even when a genetic preference could evolve as an alternative). In addition, we found that such learning promotes speciation because it increases the intensity of disruptive selection (see also Egas *et al.* 2004b). Taken together, this could result in a cascade of speciation events: once the learning of habitat features starts to evolve, this not only represents progress toward speciation, but it also promotes additional speciation events by new habitat shifts. It is thus expected that in clades where the learning of habitat features occurs, the learning is not restricted to one particular species, but is widespread among closely related species. Whether habitats are evenly distributed over space, or are more or less separated areas does not matter for this expectation, because our model for learning ability can also be interpreted as a model for migration modification. In conclusion,

the learning of habitat preferences is likely to play a crucial role in the evolution of new species more often than realized so far.

Acknowledgements

We thank Michel Durinx for helping out with the multidimensional adaptive-dynamical analysis, Pim Edelaar, Rob Lachlan and Machteld Verzijden for discussions, and Carel ten Cate, Sergey Gavrilets, Patsy Haccou, Kevin Laland, Olof Leimar and an anonymous reviewer for comments on previous versions of this manuscript. This study was supported by the Research Council for Earth and Lifesciences (ALW), which is subsidized by the Netherlands Organization for Scientific Research (NWO).

References

- Balkau, B. J. & Feldman, M. W. 1973 Selection for migration modification. *Genetics* **74**, 171–174.
- Beltman, J. B. & Haccou, P. 2005 Speciation through a learned habitat preference. *Theor. Popul. Biol.* **67**, 189–202.
- Beltman, J. B., Haccou, P. & ten Cate, C. 2004 Learning and colonization of new niches: a first step toward speciation. *Evolution* **58**, 35–46.
- Bernays, E. A. 1998 The value of being a resource specialist: behavioral support for a neural hypothesis. *Am. Nat.* **151**, 451–464.
- Christiansen, F. B. 1991 On conditions for evolutionary stability for a continuously varying character. *Am. Nat.* **138**, 37–50.
- Coyne, J. A. & Orr, H. A. 2004 *Speciation*. Sinauer Associates, Inc., Sunderland, Massachusetts.
- Davis, J. M. & Stamps, J. A. 2004 The effect of natal experience on habitat preferences. *Trends Ecol. Evol.* **19**, 411–416.
- Dieckmann, U. & Doebeli, M. 1999 On the origin of species by sympatric speciation. *Nature* **400**, 354–357.
- Dieckmann, U. & Law, R. 1996 The dynamical theory of coevolution: A derivation from stochastic ecological processes. *J. Math. Biol.* **34**, 579–612.

- Diehl, S. R. & Bush, G. L. 1989 The role of habitat preference in adaptation and speciation. In *Speciation and its consequences* (eds. D. Otte & J. Endler), pp. 345–365. Sunderland, Massachusetts: Sinauer Associates.
- Dukas, R. 1999 Costs of memory: ideas and predictions. *J. Theor. Biol.* **197**, 41–50.
- Egas, M., Dieckmann, U. & Sabelis, M. W. 2004a Evolution restricts the coexistence of specialists and generalists—the role of trade-off structure. *Am. Nat.* **163**, 518–531.
- Egas, M. & Sabelis, M. W. 2001 Adaptive learning of host preference in a herbivorous arthropod. *Ecology Letters* **4**, 190–195.
- Egas, M., Sabelis, M. W., Vala, F. & Lesna, I. 2004b Adaptive speciation in agricultural pests. In *Adaptive Speciation* (eds. J. A. J. Metz & U. Dieckmann), pp. 249–263. Cambridge: Cambridge Univ. Press, *in press*.
- Eshel, I. 1983 Evolutionary and continuous stability. *J. Theor. Biol.* **103**, 99–111.
- Eshel, I. & Motro, U. 1981 Kin selection and strong evolutionary stability of mutual help. *Theor. Popul. Biol.* **19**, 420–433.
- Felsenstein, J. 1981 Skepticism towards Santa Rosalia, or why are there so few kinds of animals? *Evolution* **35**, 124–138.
- Fry, J. D. 2003 Multilocus models of sympatric speciation: Bush versus Rice versus Felsenstein. *Evolution* **57**, 1735–1746.
- Gavrilets, S. 2004 *Fitness landscapes and the origin of species*. Monographs in Population Biology 37. Princeton Univ. Press, Princeton.
- Geritz, S. A. H. & Kisdi, É. 2000 Adaptive dynamics in diploid, sexual populations and the evolution of reproductive isolation. *Proc. R. Soc. Lond. B.* **267**, 1671–1678.
- Geritz, S. A. H., Kisdi, É., Meszéna, G. & Metz, J. A. J. 1998 Evolutionarily singular strategies and the adaptive growth and branching of the evolutionary tree. *Evol. Ecol.* **12**, 35–57.
- Gillespie, J. H. 1981 The role of migration in the genetic structure of populations in temporally and spatially varying environments. iii. migration modification. *Am. Nat.* **117**, 223–234.
- Hawthorne, D. J. & Via, S. 2001 Genetic linkage of ecological specialization and reproductive isolation in pea aphids. *Nature* **412**, 904–907.

- Johnson, P. A., Hoppensteadt, F. C., Smith, J. J. & Bush, G. 1996 Conditions for sympatric speciation: a diploid model incorporating habitat fidelity and non-habitat assortative mating. *Evol. Ecol.* **10**, 187–205.
- Johnston, T. D. 1982 Selective costs and benefits in the evolution of learning. *Adv. Study Behav.* **12**, 65–106.
- Karlin, S. & McGregor, J. 1974 Towards a theory of the evolution of modifier genes. *Theor. Popul. Biol.* **5**, 59–103.
- Kawecki, T. J. 1996 Sympatric speciation driven by beneficial mutations. *Proc. R. Soc. Lond. B* **263**, 1515–1520.
- Kawecki, T. J. 1997 Sympatric speciation via habitat specialization driven by deleterious mutations. *Evolution* **51**, 1751–1763.
- Kirkpatrick, M. & Ravigné, V. 2002 Speciation by natural and sexual selection: Models and experiments. *Am. Nat.* **159**, S22–S35.
- Kisdi, E. 2002 Dispersal: Risk spreading versus local adaptation. *Am. Nat.* **159**, 579–596.
- Kisdi, É. & Geritz, S. A. H. 1999 Adaptive dynamics in allele space: Evolution of genetic polymorphism by small mutations in a heterogeneous environment. *Evolution* **53**, 993–1008.
- Kondrashov, A. S. & Mina, M. V. 1986 Sympatric speciation: when is it possible? *Biol. J. Linn. Soc.* **27**, 201–223.
- Leimar, O. 2001 Evolutionary change and darwinian demons. *Selection* **2**, 65–72.
- Leimar, O. 2005 Multidimensional convergence stability and the canonical adaptive dynamics. In *Elements of Adaptive Dynamics* (eds J. A. J. Metz & U. Dieckmann). Cambridge: Cambridge Univ. Press, *in press*.
- Leturque, H. & Rousset, F. 2002 Dispersal, kin competition and the ideal free distribution in a spatially heterogeneous population. *Theor. Popul. Biol.* **62**, 169–180.
- Matessi, C., Gimelfarb, A. & Gavrilets, S. 2002 Long-term buildup of reproductive isolation promoted by disruptive selection: How far does it go?. *Selection* **2**, 41–64.
- Maynard Smith, J. 1966 Sympatric speciation. *Am. Nat.* **100**, 637–650.
- Maynard Smith, J. 1982 *Evolution and the theory of games*. Cambridge Univ. Press, Cambridge, UK.

- Mayr, E. 1947 Ecological factors in speciation. *Evolution* **1**, 263–288.
- Mery, F. & Kawecki, T. J. 2003 A fitness cost of learning ability in *Drosophila melanogaster*. *Proc. R. Soc. Lond. B* **270**, 2465–2469.
- Metz, J. A. J. 2005 Invasion fitness, canonical equations, and global invasibility criteria for Mendelian populations. In *Elements of Adaptive Dynamics* (eds. J. A. J. Metz & U. Dieckmann). Cambridge: Cambridge Univ. Press, *in press*.
- Metz, J. A. J., Geritz, S. A. H., Meszéna, G., Jacobs, F. J. A. & van Heerwaarden, J. S. 1996 Adaptive dynamics, a geometrical study of the consequences of nearly faithful reproduction. In *Stochastic and spatial structures of dynamical systems* (eds. D. H. van Strien & S. M. Verduyn), pp. 147–194. North Holland: Elsevier.
- Papaj, D. R. & Prokopy, R. J. 1989 Ecological and evolutionary aspects of learning in phytophagous insects. *Ann. Rev. Entomol.* **34**, 315–350.
- Rice, W. R. 1984 Disruptive selection on habitat preference and the evolution of reproductive isolation: a simulation study. *Evolution* **38**, 1251–1260.
- Rueffler, C., van Dooren, T. J. M. & Metz, J. A. J. 2004 Adaptive walks on changing landscapes: Levins' approach extended. *Theor. Popul. Biol.* **65**, 165–178.
- S., B. & Lenormand, T. 2005 Evolution of migration under kin selection and local adaptation. *Evolution* **59**, 13–23.
- Stephens, D. 1991 Change, regularity, and value in the evolution of animal learning. *Behav. Ecol.* **2**, 77–89.
- Stephens, D. W. 1993 Learning and behavioral ecology: incomplete information and environmental predictability. In *Insect learning: ecological and evolutionary perspectives* (eds. D. R. Papaj & A. C. Lewis), pp. 245–264. New York: Chapman and Hall.
- Thorpe, W. H. 1945 The evolutionary significance of habitat selection. *Anim. Ecol.* **14**, 67–70.
- Turelli, M., Barton, N. H. & Coyne, J. A. 2001 Theory and speciation. *Trends Ecol. Evol.* **16**, 330–343.
- van Dooren, T. J. M. 2005 Adaptive dynamics for Mendelian genetics. In *Elements of Adaptive Dynamics* (eds. J. A. J. Metz & U. Dieckmann). Cambridge: Cambridge Univ. Press, *in press*.

- Via, S. 1991 Specialized host plant performance of pea aphid clones is not altered by experience. *Ecology* **72**, 1420–1427.
- Via, S. 2001 Sympatric speciation in animals: the ugly duckling grows up. *Trends Ecol. Evol.* **16**, 381–390.
- West-Eberhard, M. J. 2003 *Developmental plasticity and evolution*. New York: Oxford Univ. Press.
- Wiener, P. & Feldman, M. W. 1991 The evolution of dispersal in a model of mixed selfing and random mating. *Evolution* **45**, 1717–1726.
- Wiener, P. & Feldman, M. W. 1993 The effects of the mating system on the evolution of migration in a spatially heterogeneous population. *Evol. Ecol.* **7**, 251–269.

Table and Figure Legends

Table 1. The probability that a habitat is chosen for reproduction as a function of the genetic habitat preference (g), the learning ability (l), and the birthplace of an individual. Figure 1. Examples of trajectories of evolution of the specialization coefficient (a), the genetic habitat preference (g), and the learning ability (l). Notice that although the trait space is drawn as a cube, in reality the biologically meaningful trait space is only limited in the g and l directions, but not in the a direction. The outcome of directional evolution depends on σ^2 , which determines the trade-off between viabilities in the two habitats: (a) at low σ^2 , evolution leads to a population of specialists with a genetic preference for their optimal habitat; (b) at intermediate σ^2 , it depends on the initial conditions whether evolution proceeds to specialists with a genetic preference for their optimal habitat, or to generalists without habitat preference; (c) at high σ^2 , evolution ends with a population of generalists without habitat preference. Parameters: $E = 10$, $K = 10000$, $c = 0.10$, $a_A = 0$, $a_B = 1$. The elements on the main diagonal of the mutational matrix used for the calculation of the trajectories are $4x(1 - x)$ —where x represents the traits a , g , and l —while the off-diagonal elements are all zero. Figure 2. Examples of the possible end results of the individual-based simulations of evolution of the specialization coefficient (a), the genetic habitat preference (g), and the learning ability (l). The darkness of the squares indicates the number of individuals with different values of a , g and l at a particular time (a white square means that no individuals of that type are present). (a) Evolution to specialists preferring habitat A ($k_c = 10$, $\sigma^2 = 0.20$, $c = 0.04$); (b) evolution to generalists without habitat preference ($k_c = 10$, $\sigma^2 = 0.25$, $c = 0.08$); (c) speciation through a genetic habitat preference ($k_c = 5$, $\sigma^2 = 0.18$, $c = 0.05$); (d) speciation through a learned habitat preference ($k_c = 10$, $\sigma^2 = 0.18$, $c = 0$); (e) speciation through a combination of genetic and learned habitat preference ($k_c = 10$, $\sigma^2 = 0.21$, $c = 0.04$); (f) polymorphism in a and g ($k_c = 10$, $\sigma^2 = 0.21$, $c = 0.07$). Other parameters: $K = 400$, $E = 10$, $\phi = 1$, $k_s = 16$, $k_g = 16$, $k_l = 16$. The linkage scheme used in these examples was “predetermined linkage” (explanation in model description). Figure 3. The outcome of individual-based simulations of evolution of the specialization coefficient (a), the genetic habitat preference (g), and the learning ability (l) for free recombination (a), and when all loci are distributed over k_c chromosomes (b). The evolutionary end result depends on σ^2 , which determines the trade-off between viabilities in the two habitats, and on c , the cost of learning. The evolutionary outcome for each parameter combination is based on a single run. Parameters: $K = 400$, $E = 10$, $\phi = 1$ and in (b) $k_s = 16$, $k_g = 16$, $k_l = 16$.

Table 1

	born in A	born in B
reproduction in A	$f_{AA} = 1 - g(1 - l)$	$f_{BA} = (1 - g)(1 - l)$
reproduction in B	$f_{AB} = g(1 - l)$	$f_{BB} = 1 - (1 - g)(1 - l)$

Figure 1

(a) $\sigma^2=0.10$

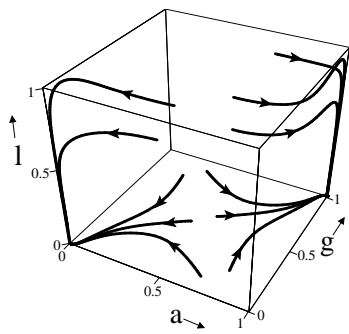

(b) $\sigma^2=0.15$

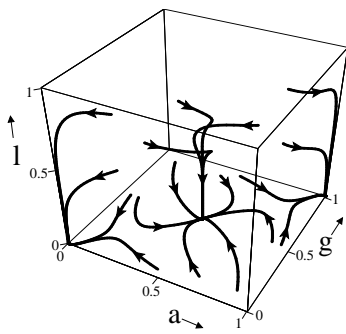

(c) $\sigma^2=0.25$

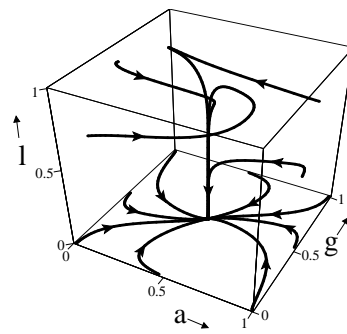

Figure 2

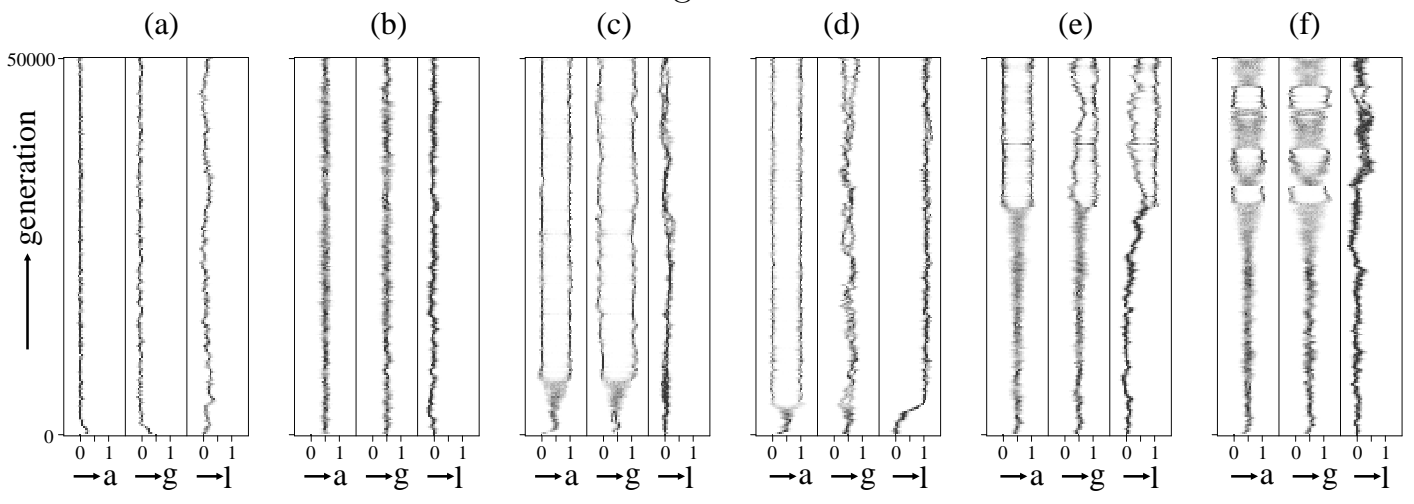
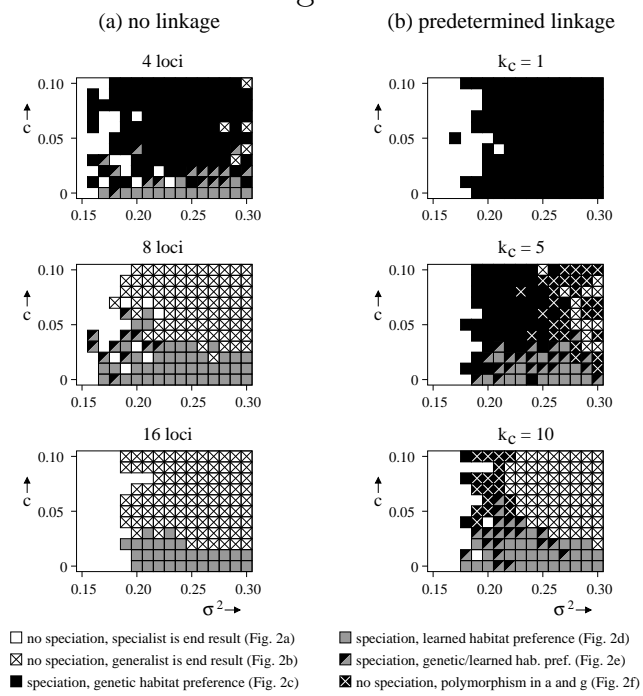

Figure 3



Electronic Appendix

The selection gradient

In the following we provide the details of the adaptive-dynamical analysis. The course of evolution of the specialization coefficient (a), the genetic habitat preference (g), and the learning ability (l) depends in part on the intensity of selection on these traits, and in part on the mutation process. To calculate the intensity of selection on each of the traits, we need to take into account that a mutant in one of the traits g , l , or a can produce offspring in both habitats. Therefore it is necessary to calculate the expected density of offspring in both habitats in the next generation for a mutant. This is represented in the “reproduction matrix” R , which has elements r_{ij} ($i, j \in \{A, B\}$) denoting the expected density of offspring in habitat i produced by an individual born itself in habitat j . For example, a mutant that is born in habitat A will produce the following density of young in habitat A (after viability selection but before density regulation):

$$w_A(a_m)E(1 - c l_m)f_{AA}(g_m, l_m) \quad , \quad (4)$$

where a_m , g_m and l_m denote the trait values of the mutant. Competition with young produced by residents results in a per capita reproduction of

$$\frac{w_A(a_m)E(1 - c l_m)f_{AA}(g_m, l_m)}{1 + Kw_A(a_r)E(1 - c l_r)(f_{AA}(g_r, l_r)\hat{N}_A(g_r, l_r, a_r) + f_{BA}(g_r, l_r)\hat{N}_B(g_r, l_r, a_r))} \quad , \quad (5)$$

where a_r , g_r and l_r denote the trait values of residents, and \hat{N}_A and \hat{N}_B denote the population densities at equilibrium. The remaining elements of the reproduction matrix are derived analogously:

$$\left(\begin{array}{cc} \frac{w_A(a_m)E(1-c l_m) f_{AA}(g_m, l_m)}{1+K \hat{Y}_A(g_r, l_r, a_r)} & \frac{w_A(a_m)E(1-c l_m) f_{BA}(g_m, l_m)}{1+K \hat{Y}_A(g_r, l_r, a_r)} \\ \frac{w_B(a_m)E(1-c l_m) f_{AB}(g_m, l_m)}{1+K \hat{Y}_B(g_r, l_r, a_r)} & \frac{w_B(a_m)E(1-c l_m) f_{BB}(g_m, l_m)}{1+K \hat{Y}_B(g_r, l_r, a_r)} \end{array} \right) \quad , \quad (6)$$

where \hat{Y}_x denotes the density of young produced in habitat x by residents at population dynamical equilibrium. When the dominant eigenvalue of the

reproduction matrix is larger than unity, a mutant in one of the traits has a nonzero probability to invade the population of residents. The dominant eigenvalue λ of our reproduction matrix equals

$$\frac{w_A f_{AA} K_B + w_B f_{BB} K_A + \sqrt{(w_A f_{AA} K_B - w_B f_{BB} K_A)^2 + 4w_A w_B f_{BA} f_{AB} K_A K_B}}{2K_A K_B}, \quad (7)$$

where for brevity in the notation it is omitted that w_A , w_B , f_{AA} , f_{AB} , f_{BA} and f_{BB} are here functions of the mutant traits, and that K_A and K_B are functions of the resident traits:

$$K_x = \frac{(1 + K w_x(a_r)) E(1 - cl_r) (\hat{N}_A(a_r, g_r, l_r) f_{Ax} + \hat{N}_B(a_r, g_r, l_r) f_{Bx})}{(E(1 - cl_r))}. \quad (8)$$

The partial derivatives of the dominant eigenvalue $\partial\lambda/\partial a_m$, $\partial\lambda/\partial g_m$, and $\partial\lambda/\partial l_m$ give the three components of the selection gradient. The sign and magnitude of these components result in directional evolution until each of the components become zero (Dieckmann & Law 1996). The trait values at which the selection gradients become zero are the equilibria of directional evolution, the so-called evolutionarily singular points. Although we could not solve the equilibrium equation in full generality, for some special points it can be shown that they are (under some circumstances) evolutionary singularities. In particular this is true when (i) the population consists of generalists without a habitat preference ($a = (a_A + a_B)/2$, $g = 0.5$ and $l = 0$), or when (ii) the population consists of specialists with a genetic preference for the habitat they are specialized on (either $a = a_A$, $g = 0$ and $l = 0$, or $a = a_B$, $g = 1$ and $l = 0$). Evolutionarily singular points have two properties that determine how evolution will proceed (Geritz *et al.* 1998, Metz *et al.* 1996). First, the convergence stability property determines whether the singular point will be approached or not. Second, the evolutionary stability property determines whether nearby mutants can invade or not when the singular point has been attained. In the following we study these two types of stability for the special points mentioned above.

Specialists with a genetic preference for their optimal habitat

At the point where the population consists of specialists with a genetic preference for the habitat they are specialized on (due to the symmetry this means either $a = a_A$,

$g = 0$ and $l = 0$ or $a = a_B$, $g = 1$ and $l = 0$), the three components of the selection gradient are $\partial\lambda/\partial a_m = 0$, $\partial\lambda/\partial g_m = -1 + E \exp(-(a_A - a_B)^2)/(2\sigma^2)$, and $\partial\lambda/\partial l_m = -c$. Hence, the component of the selection gradient in the direction of a is zero. Although the g and l components of the selection gradient are not zero, the point can still be an evolutionary singularity. This is because for g and l we are at the border of the biologically meaningful trait space (both should be between 0 and 1). This means that when the selection gradient points away from the biologically relevant part of the trait space, evolution of these traits will come to a halt. This is always true for l , and for g when

$$\sigma^2 \leq \frac{-(a_A - a_B)^2}{2 \ln(1/E)} . \quad (9)$$

In conclusion, the points $a = a_A$, $g = 0$, $l = 0$ and $a = a_B$, $g = 1$, $l = 0$ are evolutionarily singular points when inequality (9) holds. To determine the convergence and evolutionary stability of these two singular points, we need to study the components along and perpendicular to the border of the biologically relevant trait space separately. The border is formed by either the $g = 0$ and $l = 0$ or the $g = 1$ and $l = 0$ planes. To assure convergence toward the border, the selection gradient in the singular point should be exactly perpendicular to the border. A slight deviation from this direction would, for certain mutational processes, allow an evolutionary escape away from the border and thus away from the singular point (see below for a further explanation of the influence of the mutational process on the course of evolution). Here, the two planes that form the border are perpendicular to each other, and the selection gradient is indeed exactly perpendicular to the border (the a component of the selection gradient is zero). Hence, when in addition the selection gradient points toward the singular point, which is true when condition (9) is fulfilled, convergence toward the border is guaranteed. We also need to study the convergence and evolutionary stability along the border (the a direction). These can be determined from the partial second derivatives with respect to the mutant and resident. These derivatives are:

$$\frac{\partial^2\lambda}{\partial a_m^2} = -\frac{\partial^2\lambda}{\partial a_r^2} = -\frac{1}{\sigma^2} . \quad (10)$$

Hence, because $\partial^2\lambda/\partial a_r^2 > \partial^2\lambda/\partial a_m^2$ the singular points are convergence stable, and because $\partial^2\lambda/\partial a_m^2 < 0$ they are also evolutionarily stable (for these conditions see e.g. Geritz *et al.* 1998).

Generalists without a habitat preference

When the population consists of generalists without a genetic habitat preference, that is, at $a = (a_A + a_B)/2$, $g = 0.5$, the three components of the selection gradient are $\partial\lambda/\partial a_m = 0$, $\partial\lambda/\partial g_m = 0$, and $\partial\lambda/\partial l_m = -c/(1 - cl_r)$. Hence, when in addition $l = 0$ there is an evolutionarily singular point because the g and a components of the selection gradient are zero, and because the component in the l direction of the selection gradient points away from the biologically relevant trait space.

Alternatively, when there is no cost of learning ($c = 0$), there exists a whole line of singular points for all values of l (selection is then neutral in the l direction). The analysis of both cases is similar but slightly different. For the singular point at $l = 0$ (with $c > 0$), we again need to consider separately the components along and perpendicular to the border, which is formed by the $l = 0$ plane. Convergence toward the border is guaranteed because the selection gradient in the singular point is exactly perpendicular to the border (the a and g components of the gradient are zero), and points toward the singularity. Determining the convergence stability in the g and a direction (as well as the l direction when $c = 0$) is more complicated than in the case of evolution of a single trait, because in multidimensional trait spaces not only the selection gradient but also the mutation process can influence convergence stability of a singular point (Leimar 2001, 2005, Matessi & Di Pasquale 1996). In multidimensional adaptive dynamics, the mutation process is modelled by means of a mutational variance-covariance matrix, which contains information about genetic correlations between traits and about mutation probabilities of genes that underly the traits. We study when the singular point is strongly convergence stable (Leimar 2001, 2005), i.e., for all mutational matrices convergence is guaranteed for all solutions of the canonical equation of adaptive dynamics (Dieckmann & Law 1996, Durinx & Metz 2004) that start sufficiently near to the singular point. A singular point is strongly convergence stable if and only if the matrix

$$\frac{\partial^2 \lambda}{\partial x_m^2} + \frac{\partial^2 \lambda}{\partial x_m \partial x_r} \quad , \quad (11)$$

where x_r and x_m are the resident and mutant components respectively, is negative definite in the singular point (Leimar 2001, 2005). This matrix is called the Jacobian of the selection gradient (Leimar 2005). When $l = 0$, it is a two-dimensional matrix (for the l direction the convergence stability follows from the l component of the selection gradient):

$$\begin{pmatrix} \frac{(a_A - a_B)^2 e^{\frac{(a_A - a_B)^2}{8\sigma^2}} - 4\sigma^2 E}{4\sigma^4 E} & \frac{(a_B - a_A) e^{\frac{(a_A - a_B)^2}{8\sigma^2}}}{\sigma^2 E} \\ \frac{(a_B - a_A) e^{\frac{(a_A - a_B)^2}{8\sigma^2}}}{\sigma^2 E} & \frac{4(e^{\frac{(a_A - a_B)^2}{8\sigma^2}} - E)}{E} \end{pmatrix} . \quad (12)$$

This matrix is negative definite when

$$E > e^{\frac{(a_A - a_B)^2}{8\sigma^2}} \left(\frac{(a_A - a_B)^2}{4\sigma^2} + 1 \right) . \quad (13)$$

From condition (13) it can be seen that the singular point is strongly convergent stable when σ^2 is above a certain threshold. At high E the threshold is lower than at low E . The Jacobian of the selection gradient could not be determined analytically for the case that $l > 0$ and $c = 0$. Therefore, we determined when the conditions for strong convergence stability are fulfilled numerically. Again, this occurs when σ^2 is above a certain threshold. The position of the threshold is higher at high l than at low l .

Although strong convergence stability is biologically the most relevant characteristic determining whether an evolutionary singularity will be approached, sometimes such a point has the even stronger property of absolute convergence stability. When a singular point is absolutely convergence stable, this guarantees that in a certain area around the point no evolutionary escape is possible from evolution toward the singularity, independent of whatever mutations are produced, even when these are produced by a "Darwinian demon" keen on tipping the balance toward escaping (Leimar 2001). A singular point is absolutely convergence stable when condition (11) is fulfilled, and when in addition the Jacobian of the selection gradient is symmetric (Leimar 2001, 2005). In the case we study, this is always true when $a = (a_A + a_B)/2$, $g = 0.5$ and $l = 0$ (see matrix (12)). Hence, strong convergence stability then implies absolute convergence stability. In contrast, numerical analysis showed that the Jacobian of the selection gradient is not symmetric in the singular points with $l > 0$ and $c = 0$. Hence, these singular points are only strongly convergence stable, but not absolutely convergence stable.

For multidimensional adaptive dynamics, the evolutionary stability of a singular point (whether mutants can invade the resident population when the system has attained the point) is determined by the matrix $\partial^2 \lambda / \partial x_m^2$ at the singular point. When this matrix, which in our case is

$$\begin{pmatrix} \frac{(a_A - a_B)^2 - 4\sigma^2}{4\sigma^4} & \frac{a_B - a_A}{\sigma^2} & 0 \\ \frac{a_B - a_A}{\sigma^2} & 0 & 0 \\ 0 & 0 & 0 \end{pmatrix} , \quad (14)$$

is negative definite, the singular point is evolutionarily stable. Because the dominant eigenvalue of this matrix,

$$\frac{(1+l)(a_A - a_B)^2 - 4\sigma^2(1-l) + \sqrt{((1+l)(a_A - a_B)^2 - 4\sigma^2(1-l))^2 + (8(1-l)(a_A - a_B)\sigma^2)^2}}{8\sigma^4(1-l)}, \quad (15)$$

is always positive, the singular point is always evolutionarily unstable. There is thus disruptive selection at this singular point, with intensity approaching infinity when $\sigma^2 \rightarrow 0$, and zero when $\sigma^2 \rightarrow \infty$. Disruptive selection is present in both g and a direction (the exact direction depends on σ^2 , a_A and a_B as can be concluded from the accompanying eigenvector). The learning ability may be larger than zero at the singular point, because selection on l is neutral at $c = 0$, or because there may be selection pressures in favor of learning for reasons other than studied in this model (see discussion of main article). In that case, the intensity of disruptive selection is higher at high learning abilities than at low learning abilities. Hence, because speciation is more likely for strong disruptive selection than for weak disruptive selection, the presence of learning promotes speciation.

References

- Dieckmann, U. & Law, R. 1996 The dynamical theory of coevolution: A derivation from stochastic ecological processes. *J. Math. Biol.* **34**, 579–612.
- Durinx, M. & Metz, J. A. J. 2004 Multi-type branching processes and adaptive dynamics of structured populations. In *Branching processes: variation, growth and evolution of populations* (eds. P. Haccou, P. Jagers & V. A. Vatutin), pp. 278–289. Cambridge: Cambridge Univ. Press, *in press*.
- Geritz, S. A. H., Kisdi, É., Meszéna, G. & Metz, J. A. J. 1998 Evolutionarily singular strategies and the adaptive growth and branching of the evolutionary tree. *Evol. Ecol.* **12**, 35–57.
- Leimar, O. 2001 Evolutionary change and darwinian demons. *Selection* **2**, 65–72.
- Leimar, O. 2005 Multidimensional convergence stability and the canonical adaptive dynamics. In *Elements of Adaptive Dynamics* (eds. J. A. J. Metz & U. Dieckmann). Cambridge: Cambridge Univ. Press, *in press*.
- Matessi, C. & Di Pasquale, C. 1996 Long-term evolution of multi-locus traits. *J. Math. Biol.* **34**, 613–653.

Metz, J. A. J., Geritz, S. A. H., Meszéna, G., Jacobs, F. J. A. & van Heerwaarden, J. S. 1996 Adaptive dynamics, a geometrical study of the consequences of nearly faithful reproduction. In *Stochastic and spatial structures of dynamical systems* (eds. D. H. van Strien & S. M. Verduyn), pp. 147–194. North Holland: Elsevier.