

NOT FOR QUOTATION
WITHOUT PERMISSION
OF THE AUTHOR

**NITROGEN DYNAMICS IN EUROPEAN FOREST
ECOSYSTEMS: CONSIDERATIONS REGARDING
ANTHROPOGENIC NITROGEN DEPOSITIONS**

Göran I. Ågren
Pekka Kauppi

May 1983
CP-83-28

Collaborative Papers report work which has not been performed solely at the International Institute for Applied Systems Analysis and which has received only limited review. Views or opinions expressed herein do not necessarily represent those of the Institute, its National Member Organizations, or other organizations supporting the work.

INTERNATIONAL INSTITUTE FOR APPLIED SYSTEMS ANALYSIS
2361 Laxenburg, Austria

AUTHORS

Göran I. Ågren is research scientist at the Department of Ecology and Environmental Research of the Swedish University of Agricultural Sciences, S-75007 Uppsala, Sweden.

Pekka Kauppi is research scholar at the International Institute for Applied Systems Analysis, A-2361 Laxenburg, Austria.

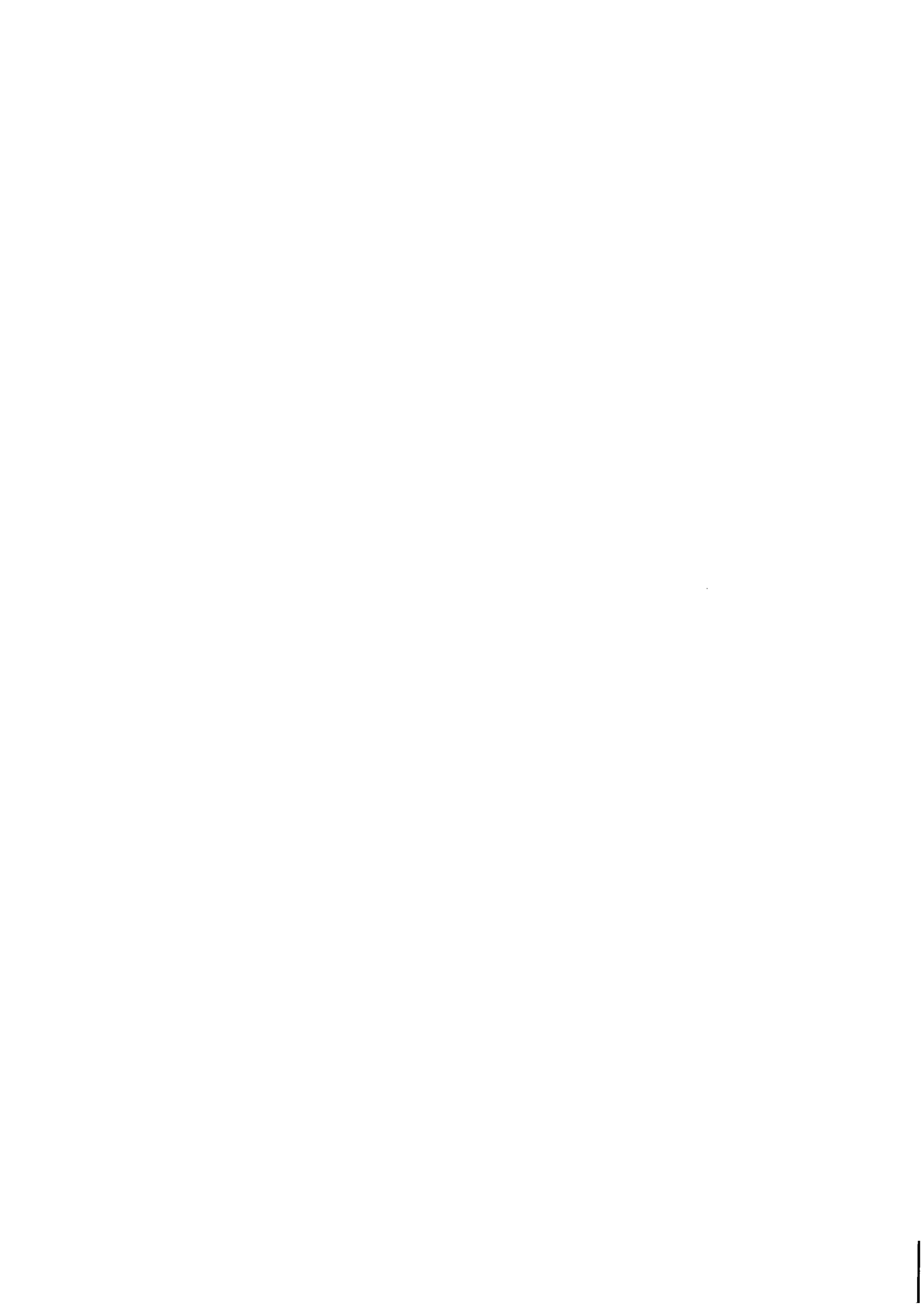

PREFACE

In collaboration with national and international organizations involved, IIASA is developing a computerized framework for the generation and analysis of scenarios of energy development, emission patterns of sulfur and nitrogen compounds and their impact on the environment. The framework will link in a modular way several submodels, each of which describes a particular aspect of the problem. This paper discusses the use in the analytical framework of the dynamic model of nitrogen in forest ecosystem developed by Göran Ågren and his co-workers in Uppsala, Sweden.

Dr. Eliodoro Runca
Impacts of Human Activities on
Environmental Systems



ACKNOWLEDGEMENT

Special thanks are due to Maximillian Posch for his assistance in computations and to Vicky Hsiung for typing the manuscript.



CONTENTS

1. INTRODUCTION	1
1.1 Nitrogen Deposition and Forest Ecosystems	1
1.2 Objectives of the Study	3
2. THEORY	4
2.1 The Nitrogen Productivity	5
2.2 A Model	6
2.3 Regional Variation	8
2.4 Other Species	10
2.5 The Saturation Point	11
3. TIME SCALES FOR NITROGEN SATURATION IN EUROPEAN FORESTS	11
4. DISCUSSION	14
5. SUMMARY	17
REFERENCES	19



NITROGEN DYNAMICS IN EUROPEAN FOREST ECOSYSTEMS: CONSIDERATIONS REGARDING ANTHROPOGENIC NITROGEN DEPOSITIONS

Göran I. Ågren and Pekka Kauppi

1. INTRODUCTION

1.1. Nitrogen Deposition and Forest Ecosystems

Anthropogenic processes emit nitrogen into the atmosphere in the form of NO_x compounds, in quantities which are of the order of one-third of the quantities of man-made sulphur emissions (Söderlund, 1977; OECD, 1979). Although sulphur deposition is the issue which receives the greatest attention and concern with regard to transboundary air pollution, nitrogen depositions cannot be neglected. The ratio of nitrogen emissions to sulphur emissions is likely to increase in the future, since the emissions of sulphur seem to be easier to control than those of nitrogen.

Sulphur emissions and concentrations have been documented extensively by OECD research programs on transboundary air pollution over large regions of Europe (OECD,1979). The studies indicate that levels of atmospheric sulphur compounds over large regions in Europe greatly exceed natural levels. Although there is an apparent lack of similar inventories regarding nitrogen, it is obvious, from information about emissions, that also nitrogen depositions in Europe have increased above their natural levels, not only near to emission sources but also over large regions surrounding industrial areas. Agricultural soils are normally treated with nitrogen fertilizer to such an extent that fertilization overrules the possible ecosystem impact of atmospheric nitrogen depositions, except for increased leaching to surrounding ecosystems. In forest ecosystems, however, the deposition of anthropogenic nitrogen may have a more substantial role.

Many technical and economical means are available for controlling nitrogen emissions; therefore, it is possible to choose between different future emission scenarios. Scientific information can assist in making policies for emission control by describing consequences of alternative scenarios. IIASA's project on transboundary air pollution has the general objective of assisting in selecting emission policies which would be effective in decreasing harmful impacts of air pollution and yet economically feasible. For that purpose the atmospheric environment group working at IIASA, with collaboration of the scientific community outside the institute, intends to provide a computerized model system consisting of several submodels. The submodels would include aspects of the energy sector, of the atmospheric transport, of deposition of pollutants, and of

impact of pollutants in the environment. Connected with that effort, this study formulates links from an existing model for describing the impact of atmospheric nitrogen deposition into the IIASA framework¹⁾.

1.2. Objectives of the Study

This study deals with the nutrient cycle of forest ecosystems over large geographic regions in Europe as affected by nitrogen deposition. The view is taken that the nitrogen cycle of a forest ecosystem has a maximum capacity for circulating nitrogen. Two different cases are defined: case (1) in which the nutrient cycle functions below its maximum capacity, and case (2) in which the circulation operates at the maximum level. In case (1), the ecosystem can absorb deposited nitrogen by adding it to the unsaturated nitrogen pool of the ecosystem. Then the nitrogen flow from the atmospheric deposition into adjacent water ecosystems is considered negligible. As the nitrogen pool of the forest ecosystem is

1) The frame model, or model system, which is being constructed at IIASA will hold several submodels each describing a specific process or phenomenon related to acidification. The submodels will not cover all potential aspects of air pollution (this would be impossible for any research program) but they will give insight into some specific processes which have received particular interest from both the political community and the scientific community working actively in this field. As this study indicates, the submodels are not developed as results of novel research but they are rather combined from existing results in collaboration with scientists outside the institute.

By providing the framework for these selected submodels, IIASA intends to offer a possibility for the political community to get information about different aspects of the field at one place. The information will be organized into a computerized form in order to make the model system easy to handle and demonstrate. The system will be operated in an interactive way. Thus a policy analyst can use it for comparing different options for emission reductions within Europe and receive a demonstration from the system about several aspects of the problem on the computer screen. All the submodels will be carefully documented, so that the user of the system will have a chance to become familiar with the assumptions and scientific uncertainties which all the models necessarily contain.

IIASA staff would select for the system a basic set of submodels, but the system would be open for any new submodels or alterations in existing models, which can be formulated in a quantitative way. For the scientific community, the model system would give an opportunity to view results of a specific field in a framework containing aspects from outside that field. Although the intention is not to produce any new scientific results but rather to reconcile existing results, the model system may be useful in treating problems which lie on some of the many borderlines connecting one established field of research to the other.

increased, the ecosystem gradually drifts towards case (2), *i.e.* nitrogen saturation. Before the saturation point, that is within case (1), depositing nitrogen increases the productivity of the ecosystem by enhancing the nitrogen cycle. After saturation, case (2), no productivity increase will take place and the excess nitrogen tends to generate adverse effects in the forest ecosystem as well as in adjacent aquatic ecosystems which receive increased leachings.

The objective of this study is to develop a method for obtaining estimates of the times when forest ecosystems become nitrogen saturated, and to apply this method, using arbitrary data, for European stands of Scots pine and Norway spruce. The study deals explicitly with the ecosystem processes taking place before nitrogen saturation, that is, case (1) as defined above. The results are presented in the form of maps of Europe, applicable to pure stands of alternative tree species, showing the time up to nitrogen saturation, assuming that the initial conditions of ecosystems and the nitrogen deposition scenarios are available as input data.

2. THEORY

One of the most important growth-limiting elements in forests is nitrogen (Cole & Rapp, 1981; Vitousek, 1982). Under these conditions, one way of studying the impact of nitrogenous compounds in the acid rain would be to follow the buildup of nitrogen in the forest ecosystem. Eventually, these will become nitrogen saturated.

Our conjecture is that as long as the nitrogen pool in the forest ecosystem does not exceed saturation, further nitrogen depositions are *per se* not harmful, although alterations in species composition, etc.,

might be occurring. The forest ecosystem can in this case incorporate the nitrogen in its internal cycle. Beyond the saturation point, however, additional nitrogen will mean increasing concentration (of nitrate) in the soil resulting in damages to the vegetation as well as losses of nitrogen due to leaching. Nitrogen can no longer be maintained within the internal nitrogen cycle of the ecosystem.

2.1. The Nitrogen Productivity

The clue to the understanding of nitrogen dynamics in the forest is the nitrogen productivity concept (Ågren, 1983a, b). This variable that originally was introduced by Ingestad (1979a) to account for laboratory experiments with controlled nutrient additions applies equally well under field conditions. Its definition is simply the amount of biomass produced per unit of nitrogen in that biomass per unit of time. When applied to production data of needle biomass for several coniferous species, Ågren (1983a) showed that the nitrogen productivity ($P_{(N)}$) becomes a linear decreasing function of the needle biomass (W).

$$P_{(N)} = a - bW \quad (1)$$

This decrease could be explained in terms of the increasing internal shading within the canopy layer with the increasing needle biomass.

2.2. A Model

With the nitrogen productivity concept it is easy to formulate a model of tree growth. For simplicity we will restrict the analysis to the growth of the needle biomass. If it is desirable, production of other components can be estimated from knowledge of the needle biomass. Moreover, the needle biomass which has a rapid turnover should be the most sensitive indicator of the above-ground organs of the tree to changes in the environment.

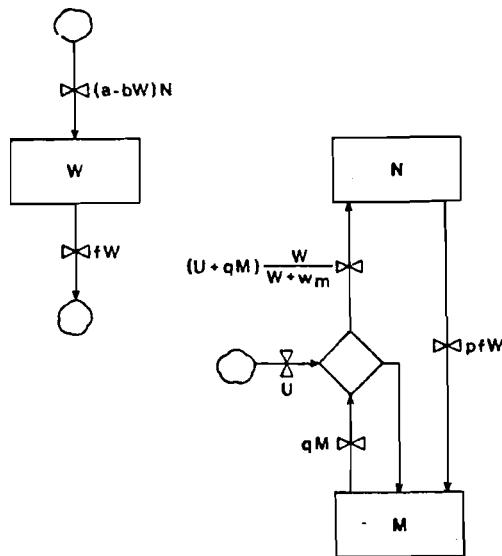

Figure 1. Flowchart of the model. W and w_m are the biomasses of tree needles and ground vegetation, respectively. N and M are nitrogen amounts in the tree needles and "soil", respectively. U represents nitrogen deposition. Lower case letters denote parameters.

Figure 1 model, requires only three state variables: W = the amount of needle biomass; N = the amount of nitrogen in the needle biomass; M = the amount of nitrogen in the "soil". The soil system is defined as that nitrogen component in the soil that is turning over rapidly and thus should be more or less in equilibrium with the nitrogen in the needle biomass. Growth of the needle biomass is described by the nitrogen productivity concept $(a - bW)$, whereas death of needles is assumed to occur at a constant rate, f . Soil nitrogen is released and made available to the vegetation as a constant fraction per unit time, q . External inputs of nitrogen (U) are added to this flow. Field experiments with fertilizers indicate that about 20% of this external input of nitrogen can be expected to be absorbed in the rapid circulation described by the model (Ingestad *et al.*, 1981; Nömmik & Möller, 1981). The trees cannot absorb all this nitrogen but only a fraction of it corresponding to their share of the total leaf biomass in the forest $(W/(W + w_m))$. In this way competition for nitrogen is described as occurring between two different types of vegetation. The leaf biomass of the other vegetation is, for simplicity, assumed constant. Dead needles, when falling, are assumed to contain a constant concentration of nitrogen, p . These assumptions can now be summarized in the following systems of equations (capital letters refer to state or exogenous variables, whereas lower case letters denote parameters):

$$\frac{dW}{dt} = (a - bW)N - fW \quad (2a)$$

$$\frac{dN}{dt} = (U + qM) \frac{W}{W + w_m} - pfW \quad (2b)$$

$$\frac{dM}{dt} = U - \frac{dN}{dt} \quad (2c)$$

During most of the rotation period of a boreal forest, say 80 out of 100 years, the needle biomass is essentially in a stationary (constant) state. The stationary needle biomass W^* is therefore an important characteristic of the forest. It is calculated by taking all derivatives in Eqs. (2a, 2b, 2c) and hence also U equal to zero. By introducing $T=N+M$, the total pool of nitrogen in rapid turnover, in Eq. (2b), N^* can be calculated as a function of W^* . Inserting this function in Eq. (2a) and expanding parentheses yields a quadratic equation in W^* :

$$pfbW^{*2} - (bqT+qf+pfaw_m)W^* + qTa - pfaw_m = 0 \quad (3)$$

The situation under consideration here is not one of true stationarity, U is never zero. In fact, it is the consequences of the nonzero U that interests us. Eq.(3) can, however, still be used. We make the adiabatic assumption that the nitrogen depositions are so small that the system can at any moment be regarded as in a stationary state, but a stationary state slowly drifting in time with the changing T .

2.3. Regional Variation

The model employs six parameters. Four of these are characteristic of the tree species (a , b , f , and p ,). Values for them are given in Table 1. These parameter values have been derived using data for stands with very different geographical locations. Hence, no regional variation should be introduced in these parameters.

Table 1. Parameter values for some coniferous species (from Ågren, 1983a, d)

Species	Parameter			
	a kgdw (kgN) ⁻¹ y ⁻¹	b ha (kgN) ⁻¹ y ⁻¹	f g ⁻¹	p kgN (kgdw) ⁻¹
Norway spruce (<i>Picea abies</i>)	18.4	0.000377	0.15	0.008
Douglas fir (<i>Pseudotsuga menziesii</i>)	34.4	0.00117	0.17	not known
Corsican pine (<i>Pinus nigra</i>)	50.2	0.00184	0.43	not known
Red pine (<i>Pinus resinosa</i>)	55.7	0.00241	0.23	not known
Scots pine (<i>Pinus sylvestris</i>)	41.4	0.00204	0.39 ^{a)}	0.004

a) This value is too high, probably due to bias in the data base. A more reasonable value is 0.3.

The remaining two parameters (w_m and q) are, on the other hand, site specific. However, w_m is in general a small number, and as long as only the stationary needle biomass is considered, it can be neglected. At least under stationary conditions q (the mineralization rate of soil nitrogen) can be taken as equal to the decomposition rate of needle litter. The latter is known to be strongly influenced by such variables as tempera-

ture and moisture, and is therefore a parameter which should be allowed to vary regionally. One suggestion about the form of this variation was suggested by Meentemeyer (1978).

2.4. Other Species

The data presented in Table 1 represent only conifers in pure stands. In view of the sound physiological base of the nitrogen productivity concept there is no doubt that it should not apply to other species as well. For a conifer not represented in Table 1 the two parameters in the nitrogen productivity (a and b) can be estimated by comparing the new species in ecological and/or physiological terms with the old ones. It is, however, sufficient to estimate either a or b in this case because a and b are strongly correlated (Ågren, 1983a) so the other one can be calculated from the following equation:

$$b = -0.53 \cdot 10^{-3} + 0.52 \cdot 10^{-4} a \quad (4)$$

The other two parameters, f and p , will have to be estimated from the knowledge of ecology species.

No parameter values of deciduous species under field conditions are known. Also, the basic model, Eqs.(2a,b,c), is based on the assumption that within-the-year variations are small. This is obviously not true of deciduous species. As a crude estimate of where saturation obtains the variation of the peak leaf biomass during the year with the nitrogen pool can probably still be calculated from Eq.(3), although with considerably larger uncertainties.

2.5. The Saturation Point

We define the system as nitrogen saturated when the nitrogen concentration in the leaf biomass is the maximal attainable without tissue injury. This concentration is around 2% of dry weight for conifers (Ingestad, 1979b) although there might be species where the maximal concentration lies higher (cf. van den Burg, 1971). Deciduous species definitely permit higher nitrogen concentrations, at least up to 4% of dry weight (e.g. Ingestad, 1981).

It is a peculiar feature of Eqs.(2a, b, c) that they give very simple equations for the stationary needle biomass and the corresponding nitrogen pool as functions of the leaf nitrogen concentration. Hence,

$$W^* = \frac{a - f / (N / W)^*}{b} \quad (5)$$

and

$$T = \left(\frac{pf}{q} + \left(\frac{N}{W} \right)^* \right) W^* \quad (6)$$

Particularly, Eqs.(5) and (6) can, of course, be used with the maximal nitrogen concentration to estimate the maximal leaf biomass and the maximal possible nitrogen pool.

3. TIME SCALES FOR NITROGEN SATURATION IN EUROPEAN FORESTS

Using the model we now predict the limit when a forest ecosystem can no longer accommodate further nitrogen deposition. This requires us to make three assumptions:

1. We assume that initially the geographical distribution of the nitrogen depositions are equal to one-third of those estimated by OECD (1979) for sulphur deposition in 1974. Assumption of the proportion is in agreement with Finnish deposition measurements (Järvinen & Haapala, 1980; Järvinen, 1982). If needed, more sophisticated ways can be introduced later for incorporating deposition information into the model. The deposition rate of nitrogen then increases by 4% per year. This rate corresponds to the observed rates in Europe in the past (OECD, 1979, pp. 2-11 and 3-31, Wentzel, 1982). Of the total nitrogen deposition, only 20% enters the needle-soil cycle defined by the model (see Ingestad *et al.*, 1981).
2. We assume that the mineralization of soil nitrogen is constant and equal to 0.2 y^{-1} for the whole of Europe. This value is too high for the northern European countries but probably rather reasonable for Central Europe. As a consequence we tend to underestimate the time required for saturating, for example, in the Scandinavian forests.
3. We have to define the initial nitrogen pools in the forests. Again we assume all forests to be equal, but we will consider two alternatives. In the first we take a Scots pine forests with a nitrogen pool of 85 kg N/ha. Such a forest should have an annual stem volume production of around 6 m^3 per hectare. The second forest type we consider is a Norway spruce forest with an initial nitrogen pool of 250 kg N ha^{-1} . In this forest we estimate the annual stem volume production to 15 m^3 per hectare.

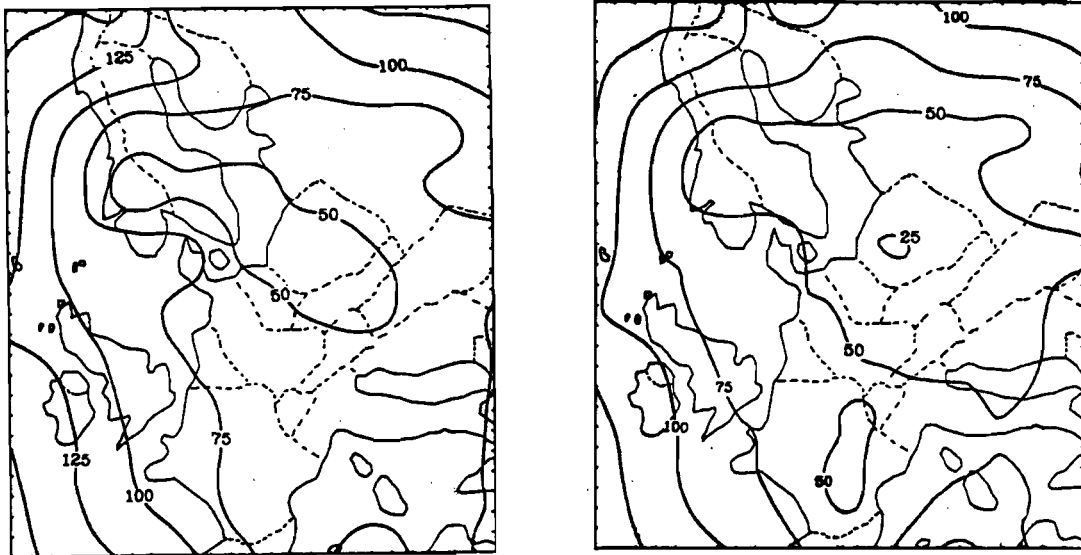

Figure 2. Time (in years) required to reach nitrogen saturation in European forests as predicted by the model. Parameters adjusted for Norway spruce (*left*) and Scots pine (*right*).

The output from this analysis is presented in Figure 2. At this point the input data are arbitrary with regard to nitrogen deposition scenarios and realistic initial conditions of the nitrogen cycle. Nonetheless, tentative conclusions can be drawn from Figure 2. There seems to be substantial regional differences as well as differences due to species composition in

the times required to saturate forests with nitrogen. In central Europe the typical times to saturate a pine forest on medium soils are of the order of thirty years, whereas in northern Scandinavia, over one hundred years are required. With spruce forests the times required to reach saturation are typically 50% longer. The longer times required by the spruce forests are, of course, a reflection of their possibility of holding higher needle biomasses and consequently in absorbing more nitrogen.

The forests chosen for this exercise were corresponding to ones growing at medium sites. Yet, these tentative results indicate that in the regions of highest deposition estimates, the forests can only absorb the nitrogen deposition for another two decades. Hence, forests growing at good or very good sites are likely, in these regions, to be already nitrogen saturated or at least to become so in a relatively short time.

It is desirable to obtain input data in the future, which would be based (i) on inventories or at least on thoroughly investigated estimates on initial conditions of nutrient cycle in European forests, and (ii) on alternative nitrogen emission scenarios. The principal outcome of this study is a method which is now available for demonstrating results corresponding to such new data.

4. DISCUSSION

IIASA activities in the field of Transboundary Air Pollution have taken the general goal of assisting in selecting pollutant emission policies which would be effective in reducing impacts and yet be economically feasible. This report was restricted in its view to obtain a well defined focus for the study. The paper serves the main goal of the IIASA activities in two ways,

first by treating the specific topic of impacts of nitrogen deposition on forest ecosystems in an explicit way and second, by describing an example of how one can implement a computerized submodel into the IIASA frame model. By means of that framework this nitrogen productivity model is introduced into a policy-oriented context.

The focus of this paper has been estimating how much nitrogen the European forests can absorb without being damaged or without leaching large quantities to surrounding ecosystems. The model as such, however, is not limited to answering only this question but could also be used for analyzing a wide range of questions about the dynamics of forests under the influence of high nitrogen deposition rates.

The explicit analysis was restricted to conditions before nitrogen saturation of ecosystems, that is, to case (1) as defined in the introduction. What will happen beyond the saturation point is not well understood. However, the nitrate ion has a very high mobility and one fate for nitrogen not absorbed by the vegetation-soil system must be leaching from the forest ecosystem to the groundwater and adjacent ecosystems. To the extent that nitrogen is retained in the soil system and high nitrate concentrations are build up, we should expect damage to the vegetation. It is possible that such damages do not occur until quite high concentrations have built up, but they then take on a more or less catastrophic aspect (cf. Ingestad *et al.*, 1981, Fig. 1).

Within the phase of increasing nitrogen pool, there are interesting aspects of ecosystem processes which had to be left out of the model at this point. Under certain conditions the soil system might be changed due to the deposition of nitrogen. With the increasing nitrogen

concentration in the living needles it is possible that their chemical composition will change with ensuing changes in decomposition rates. The increasing needle biomasses of the forests will also mean changing microclimate in the soil, but it is unknown how much this could change decomposition rates.

Indirect effects of the increasing nitrogen pool in a forest are also to be expected. Ågren (1983c) showed that the stability properties of a forest varied with its fertility. With respect to certain types of perturbations the forest will become more stable as a result of the increasing fertility, but with respect to others, it will become less stable. One particular problem that might arise is that the larger needle biomasses following the nitrogen depositions will lead to higher evapotranspiration from the forest exposing the forest to greater risks of drought.

We have, so far, only considered the effects of nitrogen in isolation. Many of the parameters used in the analysis have been derived from fertilizer trials with balanced input of elements. The input of elements to the forest from deposition is not balanced from the point of view of the biology of the vegetation. It is therefore possible that the calculated times to reach nitrogen saturated systems are overestimates. Another question is to what extent the other components, e.g. sulphur, of the acid rain could damage the forests and hence change their capacity to absorb the nitrogen depositions. Sulphur is, for example, known to reduce the photosynthetic capacity of trees. Such effects could be introduced into the model by decreasing the value of the parameter α . High concentrations of sulphur dioxide could also lead to precipitate needle death, which can be described by increasing the value for parameter f . Both these

changes will lead to decreased maximal needle biomasses and thus lower capacity of the forest to absorb nitrogen. The acid deposition also ought to influence the nitrogen mineralization rate of the soil system, but both experimental (Tamm & Wiklander, 1980; Tveite, 1980) and theoretical (Ågren, 1983d; Bosatta, 1982) results indicate that the feedback system of the soil is rather robust and no major changes in the net mineralization rates are therefore to be expected. Other processes which are not directly connected to nitrogen mineralization are also taking place in forest soils subject to acid deposition. Some of them may produce compounds which are toxic either to tree roots or to the microorganisms involved in the nitrogen cycle (Ulrich, 1982). The method introduced here can, in principle, incorporate also such processes.

5. SUMMARY

The main components of the so-called "acid rain" are sulphur and nitrogen compounds. This study deals with the impact of nitrogen deposition on productivity of forest ecosystems. The view is taken that up to a certain point, deposited nitrogen is absorbed by the ecosystem and, during this phase, acts as a fertilizer increasing the productivity of the stand. Sooner or later, however, the ecosystem is saturated with nitrogen, the productivity can no longer be enhanced, and the deposited nitrogen will have the potential of causing damage to the forest and, through increased leaching, to adjacent ecosystems.

Based on a model of nitrogen dynamics in forest ecosystems by Ågren and co-workers, a method is developed in this study for estimating the time required for European forest ecosystems to reach nitrogen

saturation. As input data the method requires information about the nitrogen content in the needle biomass in the forests and estimated data about future depositions. The method is applied, using arbitrary data, to European stands of Scots pine and Norway spruce. As output, isolines on a map of Europe indicating the time until nitrogen saturation in the specified ecosystems are depicted (Figure 2).

REFERENCES

- Ågren, G.I. 1983a. *Nitrogen productivity of some conifers*. Can. J. For. Res. 13: (in press).
- Ågren, G.I. 1983b. *The concept of nitrogen productivity in forest growth modelling*. Mitteilungen der Forstlichen Bundesversuchsanstalt, 147:199-210.
- Ågren, G.I. 1983c. *Model analysis of some stability properties of northern coniferous forests*. Lesovednie (in press).
- Ågren, G.I. 1983d. *Model analysis of some consequences of acid precipitation on forest growth*. In: Ecological effects of acid deposition. National Swedish Environment Protection Board. Report, PM 636:233-244.
- Bosatta, E. 1982. *Acidification and release of nutrients from organic matter - a model analysis*. Oecologia (Berl.), 55:30-33.
- Cole, D.W. & Rapp, M. 1981. *Elemental cycling in forest ecosystems*. In: Reichle, D.E. (ed.) Dynamic properties of forest ecosystems. (International Biological Programme; 23) Cambridge University Press. pp. 341-409.
- Ingestad, T. 1979a. *Nitrogen stress in birch seedlings. II. N, K, P, Ca, and Mg nutrition*. Physiol. Plant. 45:149-157.
- Ingestad, T. 1979b. *Mineral nutrient requirements of Pinus sylvestris and Picea abies seedlings*. Physiol. Plant. 45:373-380.
- Ingestad, T. 1981. *Nutrition and growth of birch and grey alder seedlings in low conductivity solutions and at varied rates of nutrient additions*. Physiol. Plant. 52:454-466.

- Ingestad, T., Aronsson, A. & Ågren, G.I. 1981. *Nutrient flux density model of mineral nutrition in conifer ecosystems*. Stud. For. Suec., 160:61-71.
- Järvinen, O. 1982. *Sadeveden happamoituminen Suomessa. (English summary: The acidification of precipitation in Finland)*. Luonnon Tutkija, 86:7-10.
- Järvinen, O. & Haapala, K. 1980. *Sadeveden laatu Suomessa 1971 - 1977. (Quality of precipitation in Finland 1971- 1977)*. National Board of Waters, Report 198, Helsinki.
- Meentemeyer, V. 1978. *Macroclimate and lignin control of decomposition rates*. Ecology, 59:465-472.
- Nömmik, H. & Möller, G. 1981. *Nitrogen recovery in soil and needle biomass after fertilization of a Scots pine stand, and growth response obtained*. Stud. For. Suec. 159:1-37.
- OECD 1979. *The OECD programme on long range transport of air pollutants*. OECD, Paris.
- Söderlund, R. 1977. *NO_x pollutants and ammonia emissions - A mass balance for the atmosphere over NW Europe*. Ambio, 6:118-122.
- Tamm, C.O. & Wiklander, G. 1980. *Effects of artificial acidification with sulfuric acid on tree growth in Scots pine forest*. In: Drabløs, D. & Tollan, A. (eds.) Ecological impact of acid precipitation. Proc. Int. Conf. Ecol. Impact acid precip. SNSF - Project, Norway, 1980, pp. 188-189.
- Tveite, B. 1980. *Effects of acid precipitation on soil and forest. 9. Tree growth in field experiments*. Ibid, 206-207.
- Ulrich, B. 1982. *Effects of air pollution on forest ecosystems and waters - the principles demonstrated at a case study in Central Europe*. Proc. Joint IIASA/WHO Workshop on Ambient Air Pollution, IIASA, Laxenburg, Austria.
- van den Burg, J. 1971. *Some experiments in the mineral nutrition of forest tree seedlings. (Report of a study at the Royal College of Forestry, Stockholm)*. Forest Research Station "De Dorschamp", Wageningen, Netherlands. Int. Rep. 8:1-67.