



International Institute for
Applied Systems Analysis
www.iiasa.ac.at

Dynamical Models in Quantitative Genetics

Buerger, R.

IIASA Working Paper

WP-84-088

November 1984



Buerger R (1984). Dynamical Models in Quantitative Genetics. IIASA Working Paper. IIASA, Laxenburg, Austria: WP-84-088 Copyright © 1984 by the author(s). <http://pure.iiasa.ac.at/id/eprint/2430/>

Working Papers on work of the International Institute for Applied Systems Analysis receive only limited review. Views or opinions expressed herein do not necessarily represent those of the Institute, its National Member Organizations, or other organizations supporting the work. All rights reserved. Permission to make digital or hard copies of all or part of this work for personal or classroom use is granted without fee provided that copies are not made or distributed for profit or commercial advantage. All copies must bear this notice and the full citation on the first page. For other purposes, to republish, to post on servers or to redistribute to lists, permission must be sought by contacting repository@iiasa.ac.at

NOT FOR QUOTATION
WITHOUT PERMISSION
OF THE AUTHOR

DYNAMICAL MODELS IN QUANTITATIVE GENETICS

Reinhard Bürger

November 1984
WP-84-88

Working Papers are interim reports on work of the International Institute for Applied Systems Analysis and have received only limited review. Views or opinions expressed herein do not necessarily represent those of the Institute or of its National Member Organizations.

INTERNATIONAL INSTITUTE FOR APPLIED SYSTEMS ANALYSIS
A-2361 Laxenburg, Austria

PREFACE

In this paper the author investigates models in quantitative genetics and shows that under quite reasonable assumptions the dynamics can display rather counter-intuitive behavior.

This research was conducted as part of the Dynamics of Macrosystems Feasibility Study in the System and Decision Sciences Program.

ANDRZEJ WIERZBICKI
Chairman
System and Decision
Sciences Program

DYNAMICAL MODELS IN QUANTITATIVE GENETICS

Reinhard Bürger

Institut für Mathematik, A-1090 Wien, Strudlhofgasse 4, Austria

1. INTRODUCTION

The proposition of the theory of punctuated equilibria by Eldredge & Gould (1972) and others initiated a rather controversial debate on macro-evolutionary phenomena and on the way how to explain them. One of the major points in this debate is the question whether the observed phylogenetic patterns are caused by natural selection and hence are due to adaptation or whether they are mainly due to physiological, developmental, architectural and other constraints acting on the phenotype. If the latter holds true then evolution cannot be viewed as a primarily adaptive process. Numerous contributions have been given to this subject. Let us only mention articles by Charlesworth, Lande & Slatkin (1982), Gould & Lewontin (1979), Maynard Smith (1983), Mayr (1983) and Riedl (1977).

To be able to investigate problems of macroevolution on a more quantitative and mathematical basis, it is necessary to have models that describe the evolutionary dynamics of phenotypic characters under the action of the various evolutionary and genetical mechanisms. Such a dynamical model has been proposed by Lande (1976, 1979, 1982). It is based on quantitative genetic theory and incorporates the selective forces acting on the phenotype and the pattern of variation and covariation of characters within the population. Lande's models have received a good deal of attention and have been used not only by himself (loc. cit, 1980, 1984) but by several authors to treat various topics from evolutionary theory analytically (e.g. Felsenstein 1979, Kirkpatrick 1982, Slatkin 1984, Wagner 1984 a,b). Other dynamical models for the evolution of quantitative characters have been introduced by Karlin (1979), Gimelfarb (1982) and others (see also Turelli 1984).

In a recent paper (Bürger, 1984) I used Lande's model to investigate the influence of genetic and phenotypic variance-covariance patterns for the evolution of functionally coupled quantitative characters.

In order to investigate the evolution of functionally coupled characters, I chose a fitness landscape that looked like a ridge. However, there is not only a single ridge in this landscape, there is in fact a saddle with the ridge and two hills adjacent to it. Evolution of a complex of functionally coupled characters then corresponds to moving uphill along the ridge. In order to make the analysis manageable I assumed a particularly shaped ridge, which (following Rechenberg, 1973) has been called a corridor. The result of a nonlinear analysis of the underlying dynamical system was that an unfavourable phenotypic and/or genotypic variance-covariance structure may prevent a population from moving uphill along the ridge, even if it starts at or very close to it.

Hence there exist population genetic constraints (in the intrinsic sense) restricting the directions of possible evolutionary change, although from the physiological point of view evolution into these directions is possible and even favourable. Moreover, it has been shown that in the corridor (or along the ridge) there exists an optimal variance-covariance structure resulting in an optimal evolutionary rate. This adds to results of Rechenberg (1973) and Wagner (1984 a,b). It is the purpose of the present paper to investigate whether results similar to that derived in Bürger (1984) and described above can also be obtained by using a different class of corridor models.

2. THE MODEL

Let an infinite population with overlapping generations be given that is either monoecious or dioecious with the same pattern of selection on both sexes and no sexual dimorphism. To each individual we assign a vector $\underline{z} = (z_1, \dots, z_n)^t$ where z_i , $1 \leq i \leq n$, is the value of the i -th character on some scale of measurement and t denotes transposition. The joint distribution of phenotypic characters is assumed to be multivariate normal, with mean $\underline{\bar{z}} = (\bar{z}_1, \dots, \bar{z}_n)^t$ and covariance matrix \underline{P} . This can often be arranged by some simple scale transformations (Lande 1979, Falconer 1960). Moreover, \underline{P} is split into additive genetic and environmental components \underline{G} and \underline{E} . Assuming that the vectors of additive genetic effects \underline{x} and of environmental effects \underline{e} are also multivariate normal and mutually independent and supposing that $\underline{\bar{e}} = \underline{0}$, we can write $\underline{z} = \underline{x} + \underline{e}$, $\underline{P} = \underline{G} + \underline{E}$ and $\underline{\bar{z}} = \underline{\bar{x}}$. The density function is given by

$$\gamma(\underline{z}, \underline{\bar{z}}, \underline{P}) = (2\pi)^{-n/2} (\det \underline{P})^{-1/2} \exp\left(-\frac{1}{2} \langle \underline{P}^{-1}(\underline{z} - \underline{\bar{z}}), \underline{z} - \underline{\bar{z}} \rangle\right)$$

where $\langle \underline{v}, \underline{w} \rangle = \sum_{i=1}^n v_i w_i$ denotes the usual inner product for vectors $\underline{v}, \underline{w}$ in \mathbb{R}^n .

Denoting Malthusian fitness of individuals with phenotype \underline{z} by $m(\underline{z})$, the mean fitness of the population is

$$\bar{m}(\underline{\bar{z}}, \underline{P}) = \int m(\underline{z}) \gamma(\underline{z}, \underline{\bar{z}}, \underline{P}) d\underline{z} \quad (1)$$

where $\int \dots d\underline{z}$ denotes integration over \mathbb{R}^n . The evolutionary dynamics of the vector $\underline{\bar{z}}$ is given by the following system of differential equations:

$$\dot{\underline{\bar{z}}} = \frac{d}{dt} \underline{\bar{z}} = \underline{G} \cdot (\text{grad}_{\underline{\bar{z}}} \bar{m})(\underline{\bar{z}}, \underline{P}) \quad (2)$$

where $\text{grad}_{\underline{\bar{z}}} = \left(\frac{\partial}{\partial \bar{z}_1}, \dots, \frac{\partial}{\partial \bar{z}_n}\right)^t$ (Lande 1982). A discrete analogon has been

derived by Lande (1976, 1979).

Lande (1982) has already shown that mean fitness \bar{m} is always increasing, i.e. $\frac{d}{dt} \bar{m} = \dot{\bar{m}} \geq 0$ and $\dot{\bar{m}} = 0$ if and only if $\text{grad} \bar{m} = 0$. This implies that a population is always moving uphill in the fitness landscape (but not into the direction of steepest ascent, unless \underline{G} is the identity matrix) and

therefore Lande's model provides an adaptive topography for phenotypes similar to Wright's (1932, 1969) adaptive topography for genotypes.

For investigating the evolution of functionally coupled phenotypic traits we have to specify our fitness landscape and assume that the fitness $m(\underline{z})$ of an individual with phenotype \underline{z} is of the form

$$m(\underline{z}) = sz_1 \left[\exp\left(-\frac{1}{2} \langle \underline{A}\underline{u}, \underline{u} \rangle\right) - b \right]. \quad (3)$$

Here $\underline{u} = (z_2, \dots, z_n)^t$ is a $n-1$ dimensional vector (hence $\underline{z}^t = (z_1, \underline{u}^t)$), \underline{A} denotes a positive definite matrix of dimension $n-1$ and $s > 0$ and $0 < b < 1$ are constants. Thus we have directional selection along the z_1 -axis and stabilizing selection perpendicular to it for positive values of z_1 . In our adaptive landscape we have a saddle at the origin $\underline{z} = \underline{0}$ and a ridge (with edge $\underline{u} = \underline{0}$ and increasing fitness for increasing values of $z_1 > 0$) and two hills (with increasing fitness in directions where $z_1 \rightarrow -\infty$ and $\langle \underline{A}\underline{u}, \underline{u} \rangle \rightarrow \infty$) adjacent to it. These two hills are separated by a valley with bottom $\underline{u} = \underline{0}$ and $z_1 < 0$. For the two-dimensional case the isoclines of the fitness surface are shown in Fig. 1 for different values of b . To assume that directional selection acts along the z_1 -axis is no restriction, since by applying a linear transformation \underline{T} to the state space, the direction of the ridge can be chosen arbitrarily. Instead of \underline{G} and \underline{P} one has to take the matrices $\underline{T}\underline{G}\underline{T}^t$ and $\underline{T}\underline{P}\underline{T}^t$. According to Rechenberg (1973) we shall call this a corridor model as the phenotypic states that have positive fitness (given $z_1 \geq 0$) lie within a "corridor" given by the formula $\langle \underline{A}\underline{u}, \underline{u} \rangle \geq -2 \ln b$. Rechenberg (1973) and Wagner (1984 a,b) used a somewhat related fitness landscape to investigate the existence of optimal variances and maximal evolutionary rates within the corridor. Wagner was the first who combined Rechenberg's theory with Lande's phenotypic model. In Bürger (1984) I investigated the evolutionary dynamics of a complex of functionally coupled characters using the fitness functions

$$m(\underline{z}) = sz_1 (a_0 - \langle \underline{A}\underline{u}, \underline{u} \rangle) \quad (4)$$

It is the purpose of the present note to investigate, how the results obtained there depend on the kind of fitness describing stabilizing selection along the ridge.

In order to deal with equation (2) we have to compute the population's mean fitness \bar{m} . To manage this we use the formula

$$\int \exp\left(-\frac{1}{2} \langle \underline{B}\underline{v}, \underline{v} \rangle + \langle \underline{v}, \underline{w} \rangle\right) d\underline{v} = (2\pi)^{n/2} (\det \underline{B})^{-1/2} \cdot \exp\left(\frac{1}{2} \langle \underline{B}^{-1} \underline{w}, \underline{w} \rangle\right)$$

(where $\underline{v}, \underline{w}$ in \mathbb{R}^n and \underline{B} is $n \times n$ matrix) and obtain, through integration by parts,

$$\begin{aligned} \bar{m}(\bar{z}, \underline{P}) &= s \cdot \det(\underline{I} + \underline{A}\underline{P}_1)^{-1/2} \left[\bar{z}_1 - p_{11} (p_{11} + \langle \underline{v}_p, \underline{p} \rangle)^{-1} \langle \underline{v}_p, \bar{u} \rangle \right] \cdot \\ &\quad \cdot \exp\left(-\frac{1}{2} \langle \underline{v}_p, \bar{u} \rangle + \frac{1}{2} (p_{11} + \langle \underline{v}_p, \underline{p} \rangle)^{-1} \langle \underline{v}_p, \bar{u} \rangle^2\right) - sb \bar{z}_1. \end{aligned} \quad (1a)$$

Here $\underline{P} = \begin{bmatrix} p_{11} & \underline{p}^t \\ \underline{p} & P_1 \end{bmatrix}$, $\underline{p} = (p_{12}, \dots, p_{1n})^t$ (the vector of covariances of character 1 and characters $i, i \geq 2$), P_1 is the covariance matrix of characters $2, \dots, n$. Furthermore,

$$\underline{Q} = \begin{bmatrix} q_{11} & \underline{q}^t \\ \underline{q} & Q_1 \end{bmatrix} = \underline{P}^{-1}, \quad \underline{Q}_1^{-1} = P_1 - \frac{1}{p_{11}} \underline{p} \bullet \underline{p}^t \quad \text{and} \quad \underline{V} = \underline{Q}_1 - \underline{Q}_1 (\underline{Q}_1 + \underline{A})^{-1} \underline{Q}_1 = (\underline{Q}_1^{-1} + \underline{A}^{-1})^{-1}.$$

In the special case where character 1 is uncorrelated to the other characters, i.e. $\underline{p} = \underline{0}$, we obtain:

$$\bar{m}(\bar{z}, \underline{P}) = s \cdot \det(\underline{I} + \underline{A} \underline{P}_1)^{-1/2} \cdot \bar{z}_1 \cdot \exp\left(-\frac{1}{2} \langle \underline{V} \bar{u}, \bar{u} \rangle\right) - s b \bar{z}_1 \quad (1b)$$

with $\underline{V} = (\underline{P}_1 + \underline{A}^{-1})^{-1}$.

If we consider only two characters, we obtain (with $\underline{P} = \begin{bmatrix} p_{11} & p_{12} \\ p_{12} & p_{22} \end{bmatrix}$, and $\underline{A} = a$)

$$\bar{m}(\bar{z}, \underline{P}) = s a^{-3/2} (\bar{z}_1 \alpha - \bar{z}_2 a p_{12}) \cdot \exp(-a \bar{z}_2^2 / 2\alpha) - s b \bar{z}_1 \quad (1c)$$

where $\alpha = 1 + a p_{22}$ (and $V = a/\alpha$). For the two dimensional case the isoclines of the population's fitness landscape are shown in Fig. 1.

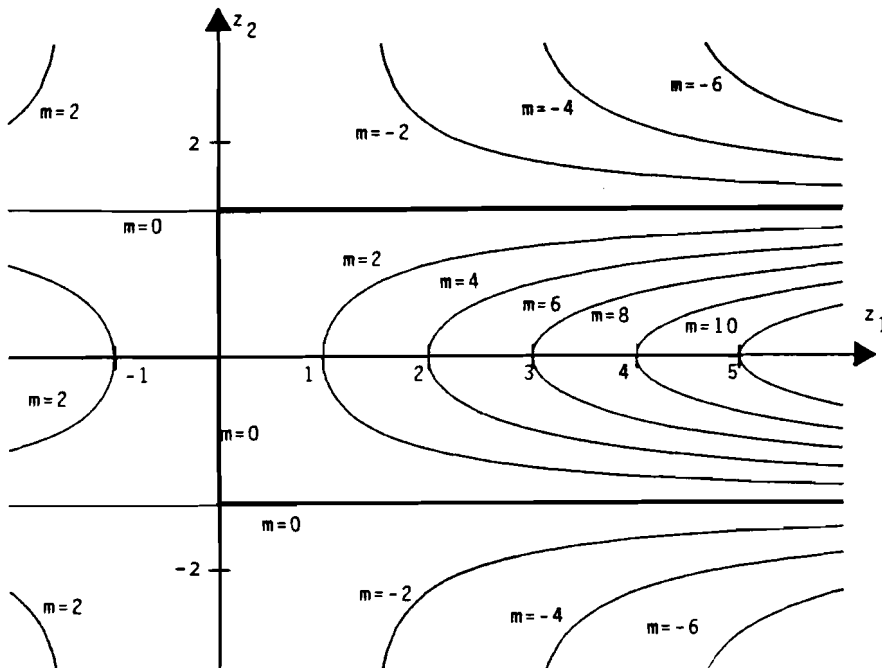

Figure 1a

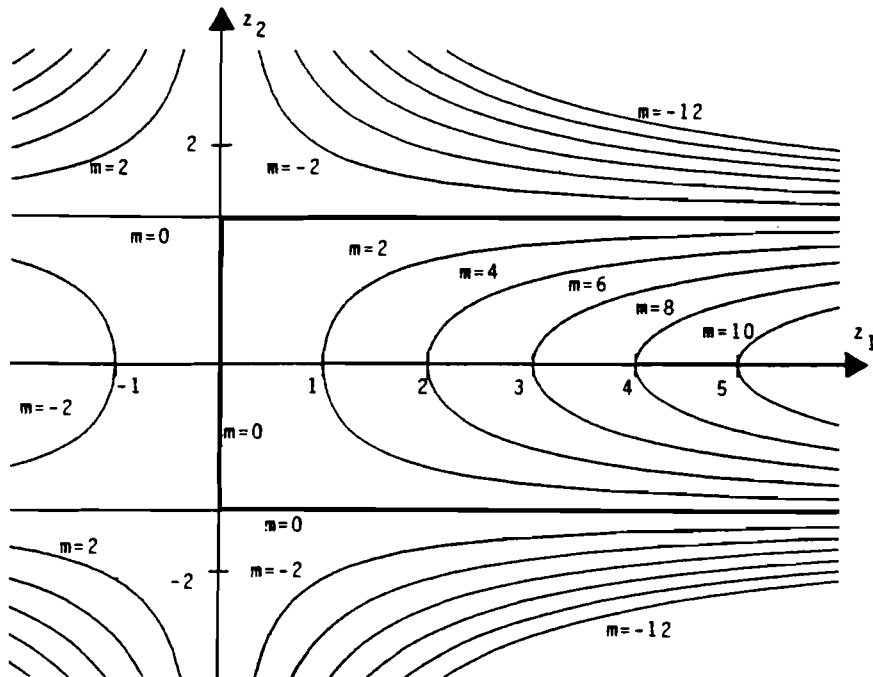

Figure 1b

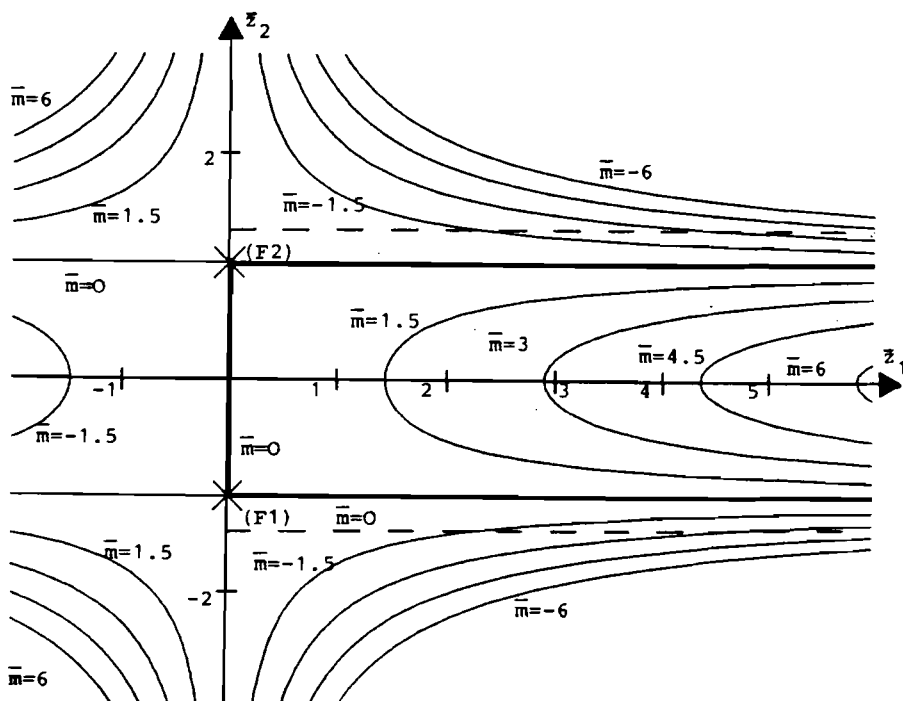

Figure 1c

Caption to Fig. 1: (1a) and (1b) show the contourlines of the individual fitness landscape according to formula (3) with $b=0.4$ in (1a) and $b=0.9$ in (1b). s and a are chosen such that in both cases the width of the individual's corridor is $BI = 2\sqrt{2}$ and the ascent is $AI = 2$. Hence the main difference between these two parameter choices is the different selective disadvantage of individuals far away from the ridge.

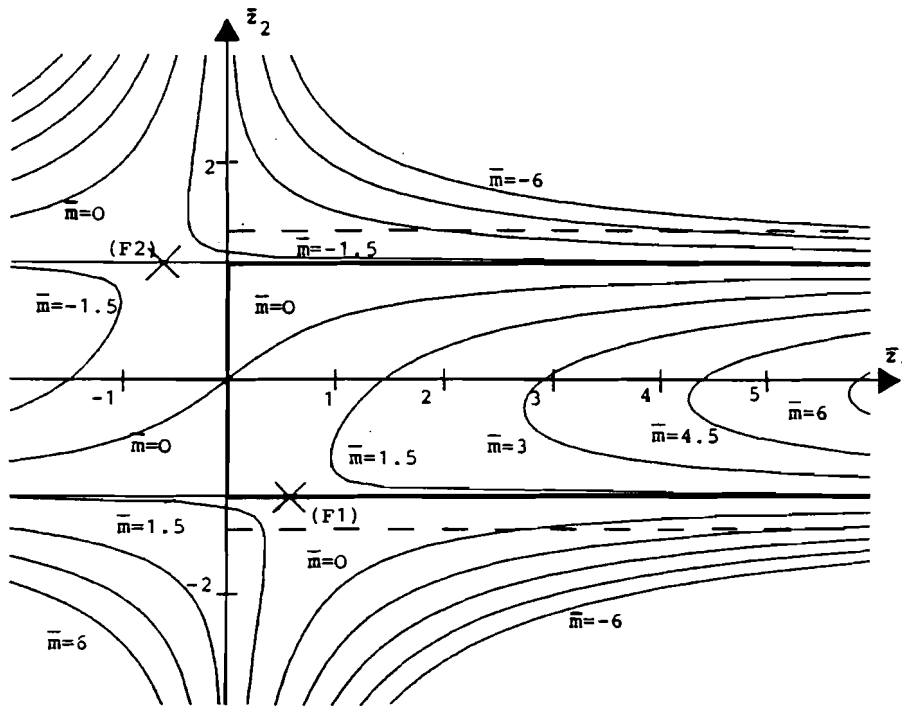

Figure 1d

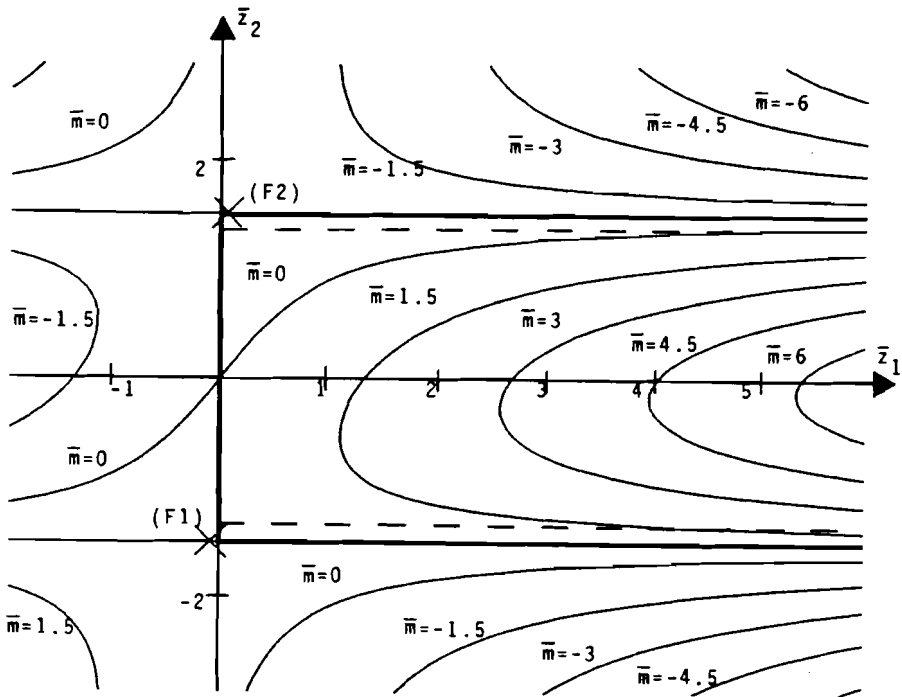

Figure 1e

Caption to Fig. 1 (continued): (1c) and (1d) show the contourlines of the population's fitness landscape corresponding to Fig.(1b) (see formula (1c)). In (1c) the phenotypic variances and covariances are $p_{11}=p_{22}=1$ and $p_{12}=0$, in (1d) they are $p_{11}=p_{22}=1$ and $p_{12}=0.75$. (1e) shows the contours of the population's fitness landscape corresponding to (1a) with $p_{11}=p_{22}=1$ and $p_{12}=0.75$. The dashed lines in (1c) - (1e) indicate the boundary of the individual's corridor, the bold lines that of the population's corridor.

3. ANALYSIS AND RESULTS.

For simplicity in the sequel we will only consider the two-dimensional case, although most of the results may be derived for n-dimensions. But see Bürger (1985) for a more general treatment. From (1c) we obtain

$$\begin{aligned} \frac{\partial \bar{m}}{\partial \bar{z}_1} &= s\alpha^{-1/2} \exp(-a\bar{z}_2^2/2\alpha) - sb \\ \frac{\partial \bar{m}}{\partial \bar{z}_2} &= -s\alpha^{-3/2} a(p_{12} + \bar{z}_1\bar{z}_2 - \bar{z}_2^2 a p_{12}/\alpha) \exp(-a\bar{z}_2^2/2\alpha). \end{aligned} \tag{5}$$

Thus (2) reads

$$\begin{aligned} \dot{\bar{z}}_1 &= g_{11} \frac{\partial \bar{m}}{\partial \bar{z}_1} + g_{12} \frac{\partial \bar{m}}{\partial \bar{z}_2} \\ \dot{\bar{z}}_2 &= g_{12} \frac{\partial \bar{m}}{\partial \bar{z}_1} + g_{22} \frac{\partial \bar{m}}{\partial \bar{z}_2} \end{aligned} \tag{2a}$$

with $\partial \bar{m} / \partial \bar{z}_i$ given above.

As the additive genetic covariance matrix G is assumed to be positive definite (and hence non-singular), the equilibrium points of system (2) must satisfy $\text{grad } \bar{m} = \underline{0}$. Together with (5) we obtain the following two equilibrium points:

$$\begin{aligned} \text{(F 1)} \quad z_1 &= -p_{12}(1 + 2\ln(b\alpha^{1/2}))/z_2, \quad z_2 = -(-2\alpha \ln(b\alpha^{1/2})/a)^{1/2} \\ \text{(F 2)} \quad z_1' &= -z_1, \quad z_2' = -z_2 \end{aligned}$$

It can be shown easily that both equilibrium points have one positive and one negative eigenvalue and hence are saddle points.

As the adaptive landscape for the population, as given by \bar{m} , may considerably deviate from the adaptive landscape for individuals, as given by m , it is necessary to discern between an individual's corridor, defined as the region $\{(z_1, z_2) : z_1 \geq 0 \text{ and } z_2^2 \leq (2\ln b)/a\}$, and a population's corridor, defined as $\{(\bar{z}_1, \bar{z}_2) : \bar{z}_1 \geq 0 \text{ and } \bar{z}_2^2 \leq (-2\alpha/a)\ln b\alpha^{1/2}\}$. In the first case this is exactly the subregion of the right half plane where individual fitness is positive and in the second case this is the subregion of the right half plane where population fitness is positive, presupposed that the characters are uncorrelated. We denote by AI = $s(1-b)$, AP = $s(\alpha^{-1/2}-b)$, BI = $2(-2(\ln b)/a)^{1/2}$ and BP = $2((-2\alpha/a)\ln b\alpha^{1/2})^{1/2}$ resp. the ascent (along the axis) of the individual's and population's corridor and the width of the individual's and population's corridors. Note that AP is - up to the factor g_{11} the evolutionary rate along the corridor axis if the characters are uncorrelated.

The first fact that should be noted is that a necessary and sufficient condition for the existence of a population's corridor (i.e. AP and BP are strictly positive) is that $b\alpha^{1/2} < 1$, or equivalently $p_{22} < (1-b^2)/ab^2$. Hence, a population can only move uphill along the ridge in our landscape if there is not too much variation in the character that is under stabilizing selection (i.e. $\dot{z}_1 > 0$ close to the axis $z_2 = 0$). The same phenomenon, namely the existence of an upper bound of adaptively reasonable phenotypic variance for the evolution of functionally coupled characters has already been observed in Bürger (1984) for the fitness function defined in (4).

However, in the present case where stabilizing selection is assumed to be Gaussian a new phenomenon arises. If $b < \exp(-\alpha \ln \alpha^{1/2}/ap_{22}) < 1$, which means that if the selective disadvantage of individuals being far away from the corridor is weak, then the population's corridor becomes wider than the individual's corridor. Furthermore, if $p_{22} < (1-b^2e)/ab^2e$ (e denotes Euler's constant), or equivalently $b\alpha^{1/2} < e^{-1/2}$, then for $p_{12} > 0$ the fixed point (F 1) lies in the left half plane and (F 2) in the right half plane, contrary to a quadratically deviating fitness function such as (4) or to the case of $b\alpha^{1/2} > e^{-1/2}$. See also Fig. 1.

Now let's turn to the dynamics of system (2a). Throughout we shall assume $b\alpha^{1/2} < 1$, i.e. there exists a population's corridor. If the two characters are genetically and phenotypically uncorrelated, so that $g_{12} = 0$ and $p_{12} = 0$ then

$$\frac{d}{dt} \bar{z}_2^2 = 2\bar{z}_2 \dot{\bar{z}}_2 = -2s\alpha^{-3/2} a g_{22} \bar{z}_1 \bar{z}_2^2 \exp(-a\bar{z}_2^2/2\alpha) \leq 0$$

if $\bar{z}_1 \geq 0$. As $b\alpha^{1/2} < 1$ we have

$$\dot{\bar{z}}_1 = g_{11}s(\alpha^{-1/2} \exp(-a\bar{z}_2^2/2\alpha) - b) \geq 0$$

for $\bar{z}_2^2 \leq BP^2/4$. Hence the population's corridor is positively invariant and each population starting within the corridor will converge to the axis and evolve along it. This result can be proved for much more general fitness functions, i.e. for functions of the form

$$m(\underline{z}) = m^0(z_1)m^1(\underline{u})$$

with $\partial m^0/\partial z_1 > 0$, $m^1(\underline{u}) = f(\langle \underline{A}\underline{u}, \underline{u} \rangle)$ and $df/dx < 0$ (Bürger 1985).

Next let us drop the assumption $p_{12} = 0$ and assume $p_{12} > 0$ (if $p_{12} < 0$ symmetrical results are obtained). Thus the characters are still genetically uncorrelated but exhibit a positive phenotypic correlation. This gives also rise to a change in the adaptive landscape (see Fig. 1 and equ. (1c)) and therefore the dynamical behaviour of the population will change, although the fitness landscape for individuals remains the same. In particular, in order to be able to move uphill in the corridor it is not sufficient for a population to start within the population's corridor, since there exists a subregion from which no evolution in this direction is possible (see Fig. 2).

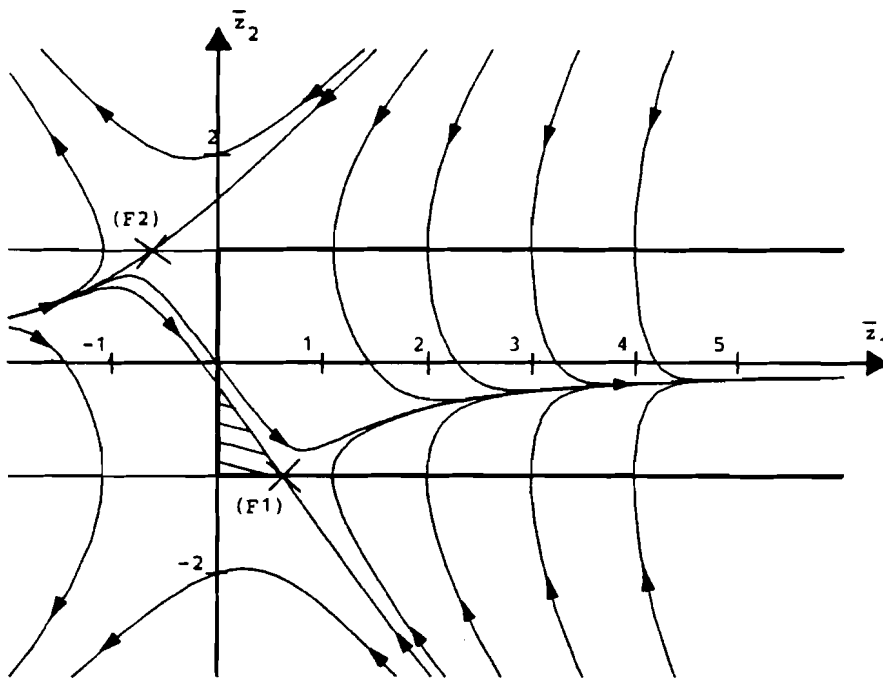

Figure 2a

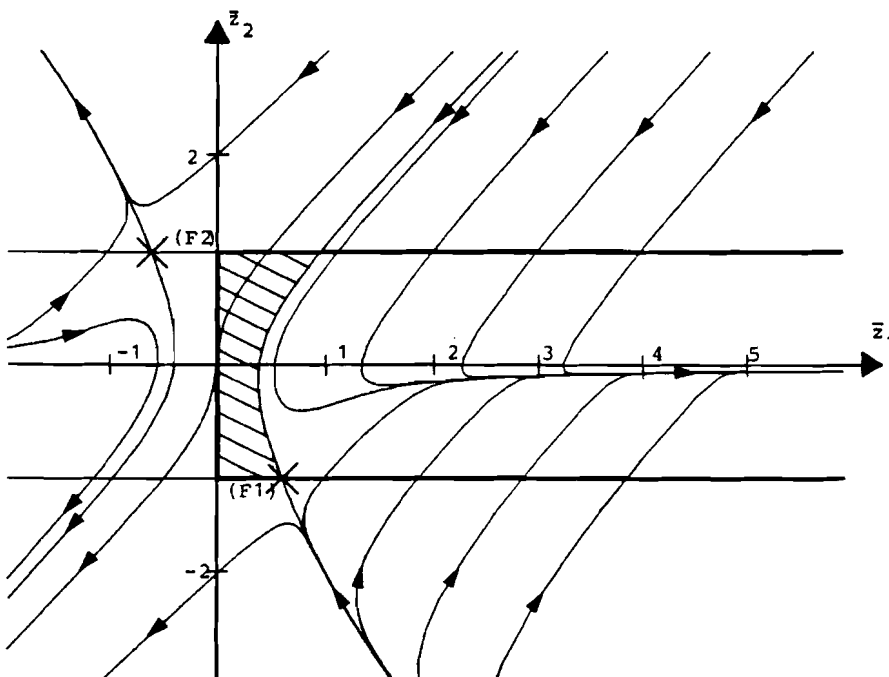

Figure 2b

Figures (2a) and (2b) show the trajectories of a population in the fitness landscape with contours as in Fig. (1d), i.e. $p_{11} = p_{22} = 1$, $p_{12} = 0.75$. The vast majority of individuals in the population has positive fitness, as the width of the individual's corridor is $2\sqrt{2}$. In (2a) the genetic covariance matrix is given by $g_{11} = g_{22} = 0.25$ and $g_{12} = 0$, in (2b) we have $g_{11} = g_{22} = 0.25$ and $g_{12} = 0.20$. The dashed area is the subregion of the corridor from which no evolution along the ridge can occur.

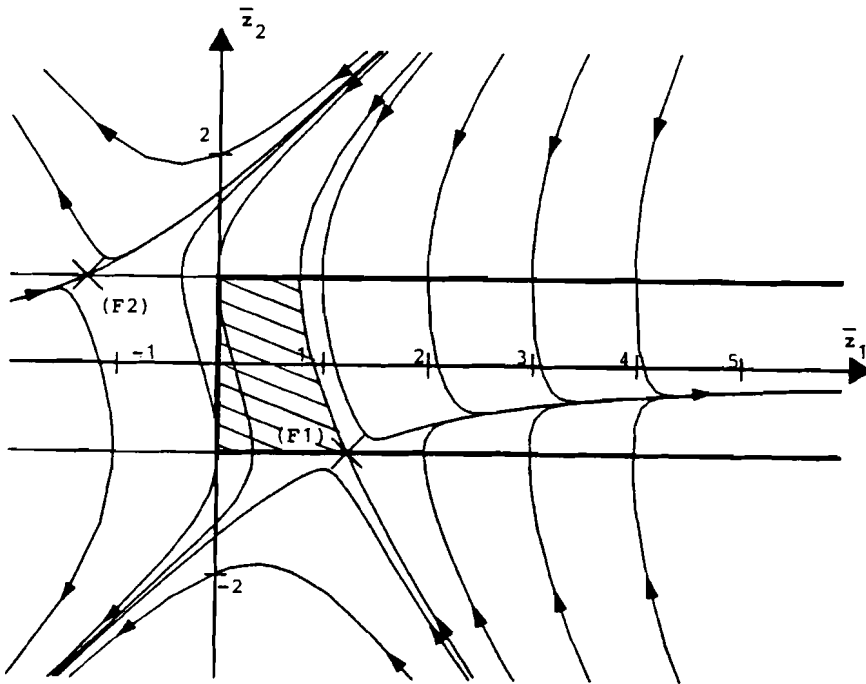

Figure 2c

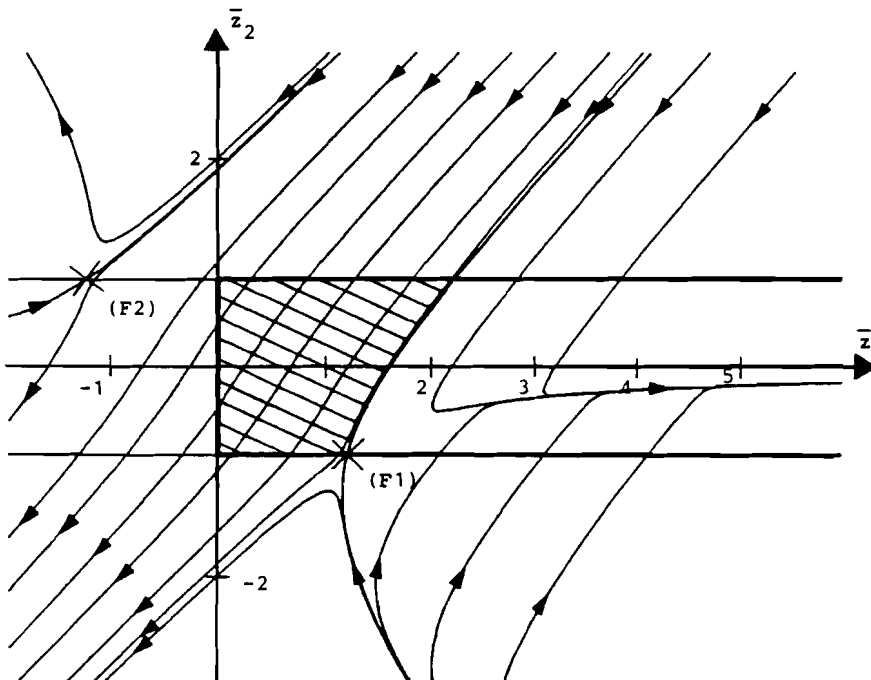

Figure 2d

Figures (2c) and (2d) show the trajectories of a population with parameters $p_{11} = p_{22} = 1.5$, $p_{12} = 1.125$, $g_{11} = g_{22} = 0.375$ and $g_{12} = 0$ (resp. $g_{12} = 0.30$) in (2c) (resp. (2d)). Thus relative to Fig. (2a) and (2b) the covariance matrices have been multiplied by a factor 1.5. Still about one half of the individuals has positive fitness. The subregion from which no evolution along the ridge can occur has been considerably increased by this change in the covariance matrices.

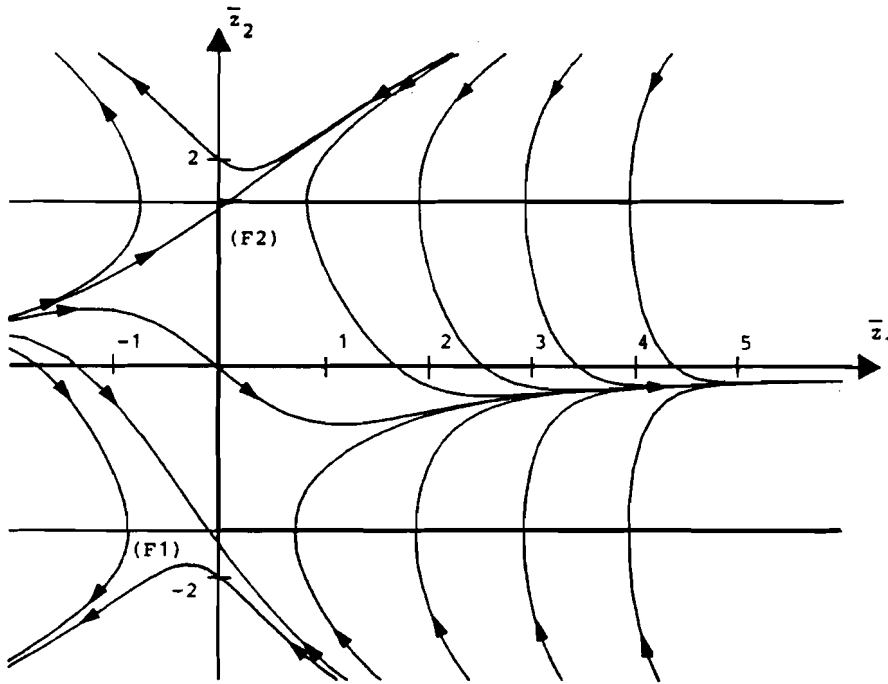

Figure 2e

Figure (2e) shows the trajectories of a population in the fitness landscape with contours as in Fig. (1e) with covariance matrices as in Fig. (2a). As in this case individuals which are far away from the corridor have only a slight selective disadvantage, no constraints for evolving along the ridge occur.

However, if the population is already sufficiently far uphill the ridge it will evolve along it. We can show analytically that convergence occurs if the population starts within the region

$$\{(\bar{z}_1, \bar{z}_2) : \bar{z}_1 \geq |z_1| \text{ and } \bar{z}_2^2 \leq z_2^2 = BP^2/4\}$$

First we already know that $\dot{\bar{z}}_1 \geq 0$ if $\bar{z}_2^2 \leq BP^2/4$. Moreover, we have

$$\begin{aligned} \frac{d}{dt} \bar{z}_2^2 &= 2\bar{z}_2 \dot{\bar{z}}_2 = \\ &= -2sa^{-3/2} a g_{22} \bar{z}_2 (p_{12} + \bar{z}_1 \bar{z}_2 - \bar{z}_2^2 a p_{12}/\alpha) \cdot \exp(-a\bar{z}_2^2/2\alpha) \end{aligned}$$

which is negativ if and only if

$$\bar{z}_1 \bar{z}_2^2 + p_{12} \bar{z}_2 (1 - \bar{z}_2^2 a/\alpha) \geq 0.$$

From this it follows immediately that the subregion of the corridor where $\bar{z}_1 \geq |z_1|$ is positively invariant. Moreover, the above relation holds if

$$\bar{z}_2^{-2} \geq \frac{|p_{12} \bar{z}_2|}{|\bar{z}_1|} |\bar{z}_2^{2(a/\alpha)-1}|.$$

As we assume $|\bar{z}_2| \leq BP/2$, the right hand side tends to zero if \bar{z}_1 tends to infinity. Thus we have shown

$$\frac{d}{dt} \bar{z}_2^{-2} \leq 0 \text{ if } BP^2/4 \geq \bar{z}_2^{-2} \geq C(\bar{z}_1),$$

with $\lim C(\bar{z}_1) \rightarrow 0$, $\bar{z}_1 \rightarrow \infty$. Together with $\dot{\bar{z}}_1 > 0$ for $|\bar{z}_2| \leq BP/2$ this proves our assertion. An analogous result has been proved for fitness given by equ. (4) (Bürger 1984). To obtain an analytical estimate for the subregion of the corridor where no convergence along the ridge can occur seems to be rather difficult. The only thing that is obvious is, that such a region exists since $\frac{d}{dt} \bar{z}_2^{-2} > 0$ for $\bar{z}_1 < z_1$ with $\bar{z}_2 = z_2$ and for $\bar{z}_1 < z_1'$ with $\bar{z}_2 = z_2'$. Phase portraits are given in Fig. 2.

Of particular importance for the size of the region from which no evolution along the corridor axis is possible, is the ratio of a (describing the strength of stabilizing selection) and p_{12} and p_{22} . If the individual's fitness landscape is held constant, and p_{12} and p_{22} are multiplied by some factor larger than 1, the population's corridor becomes narrower and the fixed point (F 1) shifts into direction of increasing \bar{z}_1 (and decreasing $|\bar{z}_2|$). Moreover, the rate of evolution $\dot{\bar{z}}_1$ along the ridge decreases significantly (see Fig. 2).

If part of the phenotypic covariance p_{12} is due to genetic covariance, i.e. $g_{12} \neq 0$, it appears that it becomes more difficult to evolve along the ridge (see Fig. 2). However we have no analytical estimates.

Finally we shall investigate a phenomenon that has been discovered by Rechenberg (1973). Rechenberg assumed a fitness function of the form

$$m(z) = \begin{cases} z_1, & |z_i| \leq C, i \geq 2 \\ 0, & \text{otherwise} \end{cases}$$

and proved the existence of an optimal amount of variance (the covariance was assumed to be zero and all variances to be equal) in the sense that this variance leads to a maximal evolutionary rate. Rechenberg's model, however, is based on optimization theory and not on population genetics. Wagner (1984 a,b) investigated this model in the framework of quantitative genetics on the basis of Lande's equations. He found that also in this context optimal variances and maximal evolutionary rates exist, but only if at least four characters are involved. For the fitness function (4) the same holds already for two characters. Subsequently we shall investigate this problem for the fitness function given by (3).

Instead of \underline{p} and \underline{g} we will consider $h\underline{p}$ and $h\underline{g}$ (where multiplication by h is componentwise) and look whether there exists an h_0 such that $\dot{\bar{z}}_1$ is maximal. For simplicity let us assume $g_{1i} = 0$, $i = 2, \dots, n$. Denoting $\underline{v}_h = (h\underline{p}_1 + \underline{A}^{-1})^{-1}$, $\underline{m}_h = \underline{m}(\underline{z}, h\underline{p})$ and $p(h) = \det(\underline{I} + h\underline{A}\underline{p}_1)$ we obtain:

$$\begin{aligned} \frac{\partial \dot{z}_1}{\partial h} &= \frac{\partial}{\partial h} (hg_{11} \frac{\partial \bar{m}_h}{\partial \bar{z}_1}) = g_{11} \frac{\partial \bar{m}_h}{\partial \bar{z}_1} + hg_{11} \frac{\partial^2 \bar{m}}{\partial h \partial \bar{z}_1} = \\ &= g_{11} s p(h)^{-1/2} \exp(-\frac{1}{2} \langle \underline{v}_h \bar{u}, \bar{u} \rangle) (1 - \frac{h}{2} \frac{p'(h)}{p(h)} + \frac{h}{2} \langle \underline{v}_h \underline{p}_1 \underline{v}_h \bar{u}, \bar{u} \rangle) - g_{11} s b. \end{aligned}$$

If we write

$$p(h) = \det(\underline{I} + h \underline{A} \underline{P}_1) = h^{n-1} \det(h^{-1} \underline{I} + \underline{A} \underline{P}_1) = \sum_{k=0}^{n-1} a_k h^k$$

we see that a_k is the $(n-1-k)$ th coefficient of the characteristic polynomial of $\underline{A} \underline{P}_1$. As $\underline{A} \underline{P}_1$ is positive definite, $a_k > 0$, $k \geq 0$, and in particular $a_0 = 1$.

It follows that $p(h)$ and $p(h)^{1/2}$ are monotonically increasing for $h \geq 0$. Moreover, $h \cdot \frac{p'(h)}{p(h)}$ increases monotonically ($h \geq 0$). To show this consider

$$\begin{aligned} h \cdot \frac{d}{dh} \left(\frac{p'(h)}{p(h)} \right) &= p(h)^{-2} (p(h) h (hp'(h))' - (hp'(h))^2) = \\ &= p(h)^{-2} \left(\sum_{k=0}^{n-1} a_k h^k \cdot \sum_{j=0}^{n-1} j^2 a_j h^j - \left(\sum_{k=0}^{n-1} k a_k h^k \right)^2 \right) = \\ &= p(h)^{-2} \sum_{k,j=0}^{n-1} h^{k+j} a_k a_j j(j-k) = \\ &= p(h)^{-2} \sum_{l=0}^{n-1} h^l \sum_{j=1}^n a_j a_{1-j} j(2j-1) > 0. \end{aligned}$$

This shows that for $\bar{u} = \underline{0}$

$$\frac{\partial \dot{z}_1}{\partial h} = g_{11} s p(h)^{-1/2} \left(1 - \frac{h}{2} \frac{p'(h)}{p(h)} - b p(h)^{1/2} \right).$$

has a unique zero h_0 if $n \geq 2$ and $b > 0$ and \dot{z}_1 has a unique maximum. This is qualitatively the same result as that for a fitness function of the form (4).

If $b = 0$ then such a h_0 only exists if $n \geq 4$, as $0 < \frac{h}{2} \cdot \frac{p'(h)}{p(h)} < \frac{n-1}{2}$ and $\lim_{h \rightarrow \infty} \frac{h}{2} \cdot \frac{p'(h)}{p(h)} = \frac{n-1}{2}$. This is the same as Wagner's (1984 a,b) result. It seems

to be probable that a negative fitness outside the corridor, considered by Wagner, leads to the existence of an optimal evolutionary rate for $n \geq 2$. By a continuity argument it can be inferred that maximal evolutionary rates also exist near the corridor axis.

4. CONCLUSIONS.

The present analysis shows that the pattern of variation and covariation in a population plays an important role for the evolution of functionally coupled characters in an adaptive landscape with multiple peaks. There are three main findings which are in best accordance with the results

derived in Bürger (1984).

(i) There exists an upper bound for the adaptively reasonable amount of phenotypic variance of characters which are under stabilizing selection. If this bound is exceeded no evolution along the ridge is possible, although physiologically it is favourable. This bound depends on the shape and width of the corridor and on the fact that we have multiple peaks.

(ii) An 'unfavourable' covariance pattern yields constraints on the possible directions of evolutionary change. We proved that if the corridor axis is collinear with one of the axis of the state space then each population with zero phenotypic and genetic covariance starting within the corridor converges to the axis and evolves along it. Hence the population will develop the selectively favoured complex of functionally coupled characters. If the corridor is in arbitrary position the condition of zero phenotypic (resp. genetic) covariance has to be replaced by the condition that one eigenvector of the matrix \underline{P} (resp. \underline{G}) points into direction of the corridor axis. If an deviation of \underline{P} and/or \underline{G} from this 'optimal' form occurs, there is a subregion of the corridor from which no evolution along the ridge is possible. Hence the complex of functionally coupled characters cannot evolve. For one and the same individual's fitness landscape this subregion increases in size if the deviation of the phenotypic and/or genetic covariances from their optimal values increases or if the phenotypic variances of the characters under stabilizing selection increase (see also (i)). In the latter case also the width of the corridor decreases. On the other hand if \underline{P} and \underline{G} as well as the width of the individual's corridor and the ascent along the ridge are held constant, the size of this subregion strongly depends (in the obvious way) on the parameter b , which measures the selective disadvantage of individuals being far away of the corridor.

(iii) There exists an optimal amount of overall variability resulting in a maximal evolutionary rate. To be precise, there is a positive number h_0 such that a population with covariance matrix $h_0 \underline{P}$ evolves at an higher rate along the ridge than any population with covariance matrix $h \underline{P}$, $h \neq h_0$.

To summarize, it has been shown that for the evolution of functionally coupled quantitative traits in a fitness landscape with multiple peaks there exists an optimal variance-covariance pattern of a population in a twofold sense. Any deviation from this pattern leads both to a restriction on the set of initial conditions enabling the population to adapt the selectively favoured configuration of characters as well as to a decrease in the rate adaptation. The constraints arising in this manner, namely the inability of a population to evolve into directions which are physiologically possible and even favourable, are population genetic constraints in the intrinsic sense as they are caused by the genetic structure of populations.

Acknowledgements: Part of this work has been done while I was summer student at IIASA. I thank IIASA for its hospitality. Moreover I thank Mrs.S. Aschan for typing the manuscript.

5. REFERENCES

- Bürger, R. (1984). Constraints for the evolution of functionally coupled characters: A nonlinear analysis of a phenotypic model. Submitted.
- Bürger, R. (1985). In preparation.
- Charlesworth, B., Lande, R. and Slatkin, M. (1982). A neo-Darwinian commentary on macroevolution. *Evolution* 36: 474-498.
- Eldredge, N. and Gould, S.J. (1972). Punctuated equilibria; an alternative to phyletic gradualism. pp. 82-115. In: *Models in Paleobiology*. Ed. T.J.M. Schopf. Freeman, Cooper and Co., San Francisco.
- Falconer, D.S. (1960). *Introduction to Quantitative Genetics*. Oliver and Boyd, Edinburgh.
- Felsenstein, J. (1979). Excursions along the interface between disruptive and stabilizing selection. *Genetics* 93: 773-795.
- Gimelfarb, A. (1982). Quantitative character Dynamics: Gametic Model. *Theor. Pop.Biol.* 22:324-366.
- Gould, S.J. and Lewontin, R.C. (1979). The spandrels of San Marco and the Panglossian paradigm: a critique of the adaptationist programme. *Proc.R. Soc.Lond.B.*: 581-598.
- Karlin, S. (1979). Models of multifactorial inheritance: I, Multivariate formulations and basic convergence results. *Theor.Pop.Biol.*15: 308-355; II, The covariance structure for a scalar phenotype under selective assortative mating and sex-dependent symmetric parental-transmission. *ibid*: 356-393; III, Calculation of covariance of relatives under selective assortative mating. *ibid*: 394-423; IV, Asymmetric transmission for a scalar phenotype. *ibid*: 424-438.
- Kirkpatrick, M. (1982). Quantum evolution and punctuated equilibria in continuous genetic characters. *Am.Nat.* 119: 833-848.
- Lande, R. (1976). Natural selection and random genetic drift in phenotypic evolution. *Evolution* 30: 314-334.
- Lande, R. (1979). Quantitative genetic analysis of multivariate evolution, applied to brain: body size allometry. *Evolution* 33: 402-416.
- Lande, R. (1980). The genetic covariance between characters maintained by pleiotropic mutations. *Genetics* 94: 203-215.
- Lande, R. (1982). A quantitative genetic theory of life history evolution. *Ecology* 63: 607-615.
- Lande, R. (1984). The genetic correlation between characters maintained by selection, linkage and inbreeding. *Genet.Res.,Camb.* To appear.
- Maynard Smith, J. (1983). The genetics of stasis and punctuation. *Ann.Rev. Gen.* 11-25.
- Mayr, E. (1983). How to carry out the adaptationist program? *Am.Nat.* 121: 324-334.
- Riedl, R. (1977). A systems-analytical approach to macro evolutionary phenomena. *Quart.Rev.Biol.* 52: 351-370.
- Rechenberg, I. (1973). *Evolutionsstrategie: Optimierung technischer Systeme nach Prinzipien der biologischen Evolution*. Frommann-Holzboog. Stuttgart-Bad Cannstatt.
- Slatkin, M. (1984). Ecological causes of sexual dimorphism. *Evolution* 38: 622-630.
- Turelli, M. (1984). Heritable genetic variation via mutation-selection balance: Lerch's Zeta meets the abdominal bristle. *Theor.Pop.Biol.* 25: 138-193.
- Wagner, G.P. (1984a). Coevolution of functionally constrained characters: Prerequisites for adaptive versatility. *Biosystems* 17: 51-55.
- Wagner, G.P. (1984b). Adaptively optimal genetic variation of quantitative characters: Theorems of existence and of the significance of morpholo-

gical integration. Preprint.

Wright, S. (1932). The roles of mutation, in beeding, crossbreeding and selection in evolution. Proc.Sixth.Int.Congr.Genet. 1: 356-366.

Wright, S. (1969). The Theory of Gene Frequencies. Vol. 2. Evolution and the Genetics of Populations. Univ. of Chicago. Press. Chicago.