

WORKING PAPER

A MODEL TO EXPLORE RESPONSES OF SPRUCE STANDS TO AIR-POLLUTION STRESS IN EUROPE

*Harald Thomasius
Mario Marsch
Jörg Wollmerstädt*

November 1989
WP-89-93

PUBLICATION NUMBER 97 of the Biosphere Dynamics Project

**A MODEL TO EXPLORE RESPONSES OF
SPRUCE STANDS TO AIR-POLLUTION
STRESS IN EUROPE**

*Harald Thomasius
Mario Marsch
Jörg Wollmerstädt*

November 1989
WP-89-93

PUBLICATION NUMBER 97 of the Biosphere Dynamics Project

Working Papers are interim reports on work of the International Institute for Applied Systems Analysis and have received only limited review. Views or opinions expressed herein do not necessarily represent those of the Institute or of its National Member Organizations.

INTERNATIONAL INSTITUTE FOR APPLIED SYSTEMS ANALYSIS
A-2361 Laxenburg, Austria

ABOUT THE AUTHORS

Harald Thomasius, Mario Marsch and Jörg Wollmerstädt are from the Technical University of Dresden, Tharandt Forestry Section, Piener Strasse 8, DDR-8223 Tharandt, German Democratic Republic.

FOREWORD

Within IIASA's Environment Program, the Biosphere Dynamics Project seeks to clarify the policy implications of long-term, large-scale interactions between the world's economy and its environment. The project conducts its work through a variety of basic research efforts and applied case studies. One such case study, the Forest Study, has been underway since March 1986 and focuses on the forest-decline problem in Europe. Objectives of the Forest Study are:

- a) to gain an objective view of the future development of the European forest resources;
- b) to illustrate the future development of forest decline attributed to air pollution and the effects of this decline on the forest sector, international trade and society in general;
- c) to build a number of alternative and consistent scenarios about the future decline and its effects; and
- d) to identify meaningful policy options, including institutional, technological and research/monitoring responses, that should be pursued to deal with these effects.

In the framework of the Forest Study a whole series of working papers on modeling forest decline in the GDR will be published. This paper is one in the GDR series under the auspices of the Forest Study. The objective of this study is to describe a preliminary model showing the behavior of pollution-damaged spruce stands.

B.R. Döös
Leader
Environment Program

ABSTRACT

Systems analysis has proven to be a suitable instrument for describing the processes taking place in pollution-damaged forest stands and for simulating the ecosystem behavior in various environmental situations. In a preliminary model showing the behavior of pollution-damaged spruce stands, site, air pollution, stand structure and management are taken into consideration. The target of this model consists of simulating system behavior under variable pollutant stressors and management strategies, and of serving as a basis for decision-making. The basic model is subdivided into the following submodels:

- "Forest stand" with management as well as external ecological factors and international modifications;
- "Leaf quantity/leaf fall";
- "Net assimilation"; and
- "Dendromass distribution".

A soil model from other authors is being incorporated. After a comparison with similar models, reference is made to further possibilities of application.

CONTENTS

1.	INTRODUCTION	1
2.	BASIC MODEL	2
3.	SUBMODELS	3
3.1.	Submodel "Forest Stand" with Management as Well as External Ecological Factors and Internal Modifications	3
3.2.	Submodel "Leaf Quantity/Leaf Fall"	5
3.3.	Submodel "Net Assimilation"	5
3.4.	Submodel "Dendromass Distribution"	6
4.	FINAL REMARKS	8
	REFERENCES	9
	APPENDIX I	10

A MODEL TO EXPLORE RESPONSES OF SPRUCE STANDS TO AIR-POLLUTION STRESS IN EUROPE

Harald Thomasius, Mario Marsch and Jörg Wollmerstädt

1. INTRODUCTION

In recent years, the methods of applied systems analysis have more and more made their way into research in forest ecology and forestry. This results from the great complexity of forest ecosystems and their management as well as the limits of traditional experimental methods for reasons of time, finance, risk, and acceptance. Research in forest damage recently has turned out to be a special and extremely fertile field of applied systems analysis in forestry. Great progress has already been made by applying various models (Grossmann 1986, Bossel et al. 1985, Bellmann et al. 1987). Thus, information on the potential reaction of pine stands growing on different sites under SO₂ stress can be given with the aid of a prognosis and decision-support model PEMU for pine worked out by Bellmann and co-authors (1987, 1988).

The target of a working group at the Tharandt Forestry Section of the Dresden University of Technology consists of working out a simulation model PEMU for spruce jointly with the Central Institute for Cybernetics (ZKI) of the GDR Academy of Sciences. The task consists of making use of gained experience, taking into account the specific characteristics of spruce growing predominantly in the highlands, and pursuing new ways of solving the various problems. Key components of this causally laid-out model are:

1. Ecological conditions of forest sites
 - (a) climatic factors
 - (i) solar radiation
 - (ii) warmth
 - (iii) wind
 - (iv) precipitation
 - (v) air humidity
 - (b) edaphic factors
 - (i) nutrient supply (especially N, Ca, Mg, P, K)
 - (ii) acidity (pH)
 - (iii) soil moisture
 - (c) pollutant stressors
 - (i) SO₂
 - (ii) complex NO_x, O_x, . . .
2. Stand structure and its effect on soils and on the microclimate.
3. Stand management, particularly thinning strategies and their subsequent effects on stand structure and thus stand climate, as well as fertilization. Here, changes in the structure caused by diverse damage (e.g., snowbreakage) should be taken into account (a partial model is available for this purpose).

With the aid of this model the following information can be gained:

1. System behavior under conditions of clean air and without thinning operations.
2. System behavior in the case of different thinning strategies.
3. System behavior in the case of different pollutant stress (type and intensity) as well as in the case of fertilization.

In this connection information is needed on:

1. the current organic-matter production, differentiated into:
 - (a) stemwood;
 - (b) branches;
 - (c) needles; and
 - (d) roots;
2. the dendromass to be removed because of mortality or thinning, differentiated as above;
3. the remaining dendromass differentiated as above and expressed in categories as used in forestry; and
4. derivation of optimum management strategies.

The parameters of the model can be checked or gauged based upon existing stands as well as yield tables.

To demonstrate adequately the numerous influential factors in the model, it was necessary to model the system behavior of forest stands under pollutant stress in a causal manner. The interval between model computations has been set tentatively at one year. Thus, on the one hand the influences of ecological and damage factors on the assimilation apparatus are modeled with still-sufficient accuracy, and on the other hand simulation of the system behavior of forest stands over production periods with acceptable expenditure is rendered possible (i.e., considering computing time!).

The model has been structured into mutually coupled partial models called "tree" (now "forest stand"), "mineralization", "soil moisture", "soil chemistry", and their further subdivision into submodels, as done by Bossel et al. (1985).

2. BASIC MODEL

A central position in the entire system is taken by the forest stand, which is characterized by known dendrometric dimensions - that at the same time are an expression of age and site - and frequency distribution of the height/diameter (h/d)-values as an expression of the sociological structure.

Changes in the forest stand result from growth (input from the submodel "dendromass distribution") and management, particularly thinnings. The latter are controlled by a density model. Subsequently, a comparison between stand condition prior to and after tree removal is made. The differences in stem number and volume calculated here determine the amount of trees to be taken out in intermediate cuttings (submodel 1). Such external meteorological factors as radiation, temperature, wind, precipitation, and air humidity, as well as various air pollutions (e.g., SO₂, NO_x, O₃) exert an influence on the forest stand. The meteorological factors as well as the SO₂ dose are modified by the forest stand, especially the canopy, the latter being characterized by the canopy-closure percentage and leaf-area index. These modified ecological variables, the nutritive condition (i.e., nutrient content in the needles) and the toxicity of the air pollutants exert an influence on photosynthesis that can be taken into account by applying appropriate reduction factors (submodel 3).

Then, the absolute amount of photosynthesis is calculated from leaf quantity (submodel 2) and the efficiency of the photosynthesis apparatus. It is calculated separately by h/d-classes. The results of photosynthesis are an assimilate pool and gross increment which, after deduction of respiration requirements and fructification, are placed at the disposal of the dendromass distribution model. With the aid of allometric relationships for the dry matter of the individual dendromass components (i.e., needles, branches, bole, roots, fine roots) varying with the h/d-value and diameter, it is possible to determine the dendromass distribution of net assimilate production using a special algorithm. By this submodel (4) the dimension and structure of the forest stand as well as leaf and fine root quantity are recorded annually.

The mineral nutrient and moisture supply as well as mineralization of dead organic matter either can be described with partial models as constructed by Bossel et al. (1985), or these factors can be accepted for the partial model "forest stand system" as nonlimiting.

3. SUBMODELS

3.1. Submodel "Forest Stand" with Management as Well as External Ecological Factors and Internal Modifications

Dimension Structure

The initial condition is described by means of a frequency distribution of the h/d-value (Weibull-distribution). In this connection a subdivision into 5 h/d-classes seems to be appropriate, which in principle correspond to the well-known tree classes (Kraft 1884). Considering that, in the case of the submodel "net assimilation", whole classes would always be excluded due to mortality, the dying-off process has to be prolonged by a differentiation within the h/d-value class so that unnatural interruptions are avoided.

Further development of the h/d-frequency distribution and dimension is obtained from the submodel "dendromass distribution". The h/d-frequency distribution can be used to determine the stand density $D = f(N, h)$ as well as the canopy closure $CCP = f(h/d, d_{1,3})$ and leaf-area index, differentiated into h/d-classes. Management is done over a stand density that may freely be chosen within the range $D_M < D_{max}$, whereby the number of trees to be removed (ΔN) results from $N = f(D_{real}, d_{1,3})$ and $N_M = f(D_M, d_{1,3})$.

The scooping-off of this amount in the h/d-classes depends upon the type of thinning. In the case of spruce, only low thinning is applied. As the mean height requisite for the computation of density changes with the removal of trees (ΔN), $\Delta N = f(D, \bar{h})$ must be determined iteratively.

The canopy-closure percentage and the leaf-area index, closely correlating with the former, influence:

- the modification of the external climatic factors in the stand, as well as
- the dose of the air pollutants over wind velocity in the stand.

External Ecological Factors and their Internal Modification

(a) Radiation

Radiation is the energy input into the ecosystem. In early model development, the photosynthetically active total radiation, as an annual mean value, will be used. If necessary, this value has to be corrected in accordance with slope angle and direction of slope. The vertical profile of the radiation regime in the stand is decisive for the organic-matter pro-

duction in the individual h/d-classes as well as light and shadow crowns. This profile is calculated with the aid of the canopy-closure percentage or the leaf-area index. For this purpose, extinction functions are at our disposal.

(b) Temperature

The net assimilation of the trees and stands depends not only upon the height of temperature, but also the duration of a period with $T > T_0$, ($T_0 = 10^\circ\text{C}$). To obtain a photosynthetically representative annual mean value, the monthly means are weighted by a temperature-dependent photosynthesis reduction (Mitscherlich-curve with a depressive course when exceeding the temperature optimum):

$$\bar{T}_a = \frac{\sum \bar{T}_i \cdot \overline{\text{RF}}_{\text{Temp},i}}{\sum \overline{\text{RF}}_{\text{Temp},i}} \quad (\text{for } \bar{T}_i \leq T_0 \quad \overline{\text{RF}}_{\text{Temp},i} = 0)$$

$$\overline{\text{RF}}_{\text{Temp},a} = \frac{\sum \bar{T}_i \cdot \overline{\text{RF}}_{\text{Temp},i}}{\sum \bar{T}_i}$$

Here,

- \bar{T}_a = representative annual mean of temperature,
- \bar{T}_i = monthly mean of temperature,
- $\overline{\text{RF}}_{\text{Temp},a}$ = annual mean value of the temperature reduction factor for the net photosynthesis, and
- $\overline{\text{RF}}_{\text{Temp},i}$ = monthly mean of the temperature reduction factor for the net photosynthesis.

This procedure, serving to calculate photosynthetically representative annual means, can also be applied to other ecological factors. For the time being a stand-internal temperature modification is not foreseen. It may possibly be necessary for the soil model.

(c) Wind Velocity

Net assimilation and movement of the polluted air are influenced by the wind velocity v_{wind} . Here, the exponential formula by Hellmann (Rosemeier 1976) can be applied to describe the wind velocity over the outer active surface. We intend to make use of the wind chart by Flemming (1986) as the input of open-air velocity in the stand which is decisive for the productivity and vitality of trees as determined with the aid of the approximation function by Tirén (1929), depending upon the canopy-closure percentage.

(d) Moisture

Two aspects of moisture are of interest:

- (i) soil moisture and its importance for the water uptake of trees; and
- (ii) air humidity in the stand and its importance for the stomatal mechanism.

For data on soil moisture, we will use such soil-moisture models as were developed by the Department of Water Sciences at Dresden University of Technology, or those developed and applied by Bossel et al. (1985).

The determination of moisture input is based upon open-air precipitation, from which evaporation and interception are deducted. The approximation by Kortüm (1961) has been applied to the former. The latter results from an approximation based on the canopy-closure percentage.

The relative air humidity in the stand is a linear function of the canopy closure and varies also with the open-air humidity ($\text{CCP} = 0$).

3.2. Submodel "Leaf Quantity/Leaf Fall"

In the partial model "forest stand system", the submodel "leaf quantity/leaf fall" serves to calculate the actual leaf quantity for the trees in the individual h/d-value classes and dimensions. The leaf quantity depends upon:

- (a) the annual leaf development, differentiated into light and shadow crown from the dendromass distribution model; and
- (b) the leaf fall as input for the partial model "mineralization" to calculate the nitrogen quantity available for plants; here, it is necessary to make a difference between natural leaf fall, and leaf fall due to external influences (e.g., the influences of pollutants, fertilization).

The relationship between needle age NA and net photosynthesis NET FS is described as a function of the degree of damage:

$$\text{NET FS} = 1 - e^{-c(\text{NA}_{\text{max}} - \text{NA})}$$

In this equation the parameter c permits quantification of the influence of pollutants and fertilization on needle aging. The point of intersection with the abscissa, at which the photosynthesis reaches zero, determines the annual maximum number of needles.

For the annual formation of new leaves, the following factors are decisive:

- (a) the annual assimilate production, varying with:
 - (i) the ecological factors that are modified by the submodel "forest stand";
 - (ii) management and the results of model computations on "snowbreakage, windbreak/windthrow";
 - (iii) the influence of air pollutants; and
 - (iv) water quantity that by the partial model "soil moisture" is placed at the disposal of assimilate production; and
- (b) the distribution strategy in the dendromass distribution model.

3.3. Submodel "Net Assimilation"

In the "net assimilation" submodel, determination of net photosynthesis depends upon:

- (a) ecological factors (radiation, temperature, wind velocity, air humidity, nutritive condition);
- (b) influence of air pollutants (SO_2 , NO_x , O_3); and
- (c) results of the partial model "soil moisture".

Here, the quantity of the SO_2 gas exchange per hour and g of dry matter is used as a measure of net photosynthesis.

Depending on production time, the dendromass annually available for distribution is calculated by multiplying the actual leaf quantity with the reduced net photosynthesis after deduction of the respired assimilates and fructification.

In model computations, the assimilate production is again determined separately by h/d-value classes at given dimensions of trees. These characteristics of the submodel "forest stand" are annually calculated with the aid of the submodel "dendromass distribution". In addition, the model section "forest stand" is used to modify the ecological factors radiation, temperature, wind velocity, and air humidity that serve to compute the reduction factors of net photosynthesis. The effect of pollutants and the reduction factor of the nutritive condition are coupled with the nutrient content in needles (e.g., N, Mg). Particularly, the partial models "soil chemistry" and "mineralization" exert an influence on the nutrient content in the needles.

Tree response to pollutants can be modeled via root and leaf paths. Assimilate production is ultimately influenced in both ways with different mechanisms. In the case of the soil path, an effect of the organic matter inputs and fertilization via the partial models "soil chemistry" (e.g., dying rate of fine roots, cf. Bossel et al. 1985) and "mineralization" on the nutrient content in the needles, and thus on the nutritive condition of the tree, can be assumed. Over the air path, it is possible to take "new-type" and "classical" forest damage into account separately.

Depending upon the NO_x and O_3 concentrations, the "new-type" forest damage is possibly effective also in the form of an assimilation poison, mainly by damage due to nutrient leaching. In the case of the "classical" forest damage, an immediate reduction of the net photosynthesis by the toxic air pollutant SO_2 is characteristic. The physiologically effective pollutant dose results from the SO_2 concentration and wind velocity inside the stand. Thus, the "peripheral effect" as observed in such pollutant-damaged areas results from:

- (a) the pollutant dose that depends upon wind velocity; and
- (b) the direct reduction of net photosynthesis as a consequence of increased wind velocity and diminished air humidity.

In the submodel "leaf quantity/leaf fall", reference was made to the relationship between nutrient content in needles and leaf aging. The algorithm for computing the assimilate production with reference to these factors is shown in Figure 1. If the assimilates determined with this submodel no longer satisfy the respiration requirements - meaning that the distribution model does not receive dendromass - one has generally to reckon with a dying-off of the tree, which then - through changes in canopy-closure percentage and leaf-area index - affects the ecological factors of the stand. When modeling the dying-off process, an additional differentiation within the h/d-value class has to be made and the problems concerning reserve matters should be taken into account.

3.4. Submodel "Dendromass Distribution"

The proportions of the different dendromass components in the total dendromass and consequently the relationships between the individual dendromass components may well be described by the allometric function $y = ax^b$. In the case of spruce, the corresponding absolute and relative values for needles, branches, bole, roots and fine roots were determined in dependence upon breast-height diameter and differentiated into h/d-classes from numerous investigations carried out by various authors. The principal results are presented in Appendix I. In this connection, the sociological position and response to mechanical load are taken into account, while age and site are expressed by means of the breast-height diameter. In the model it is therefore permitted to consider trees with equal h/d-value and diameter to be identical. The relationships of the dendromass components serve to distribute the dendromass emerging from the submodel "net assimilation" after deduction of the respiration requirement (likewise differentiated into components) and fructification. These proportional numbers have to be differentiated into h/d-value and dimension of the h/d-value class.

Further investigations must show whether a modification of the distribution strategy occurs under the influence of pollutants. These annual increments in dry matter of the individual components resulting from this algorithm have to be entered into the appropriate basic diagrams for each h/d-value class as a parallel to the abscissa. A clear determination of the new mean h/d-value and mean diameter of the h/d-value class is possible, if all new dry-matter functions depending upon the h/d-value and $d_{1,3}$ are entered into one basic diagram. The point of intersection of all curves marks the sought value. This approach corresponds with the graphical solution of an equation system. Assimilate distribution and recording of the stand-structure model is obtained in this way (cf. submodel 1).

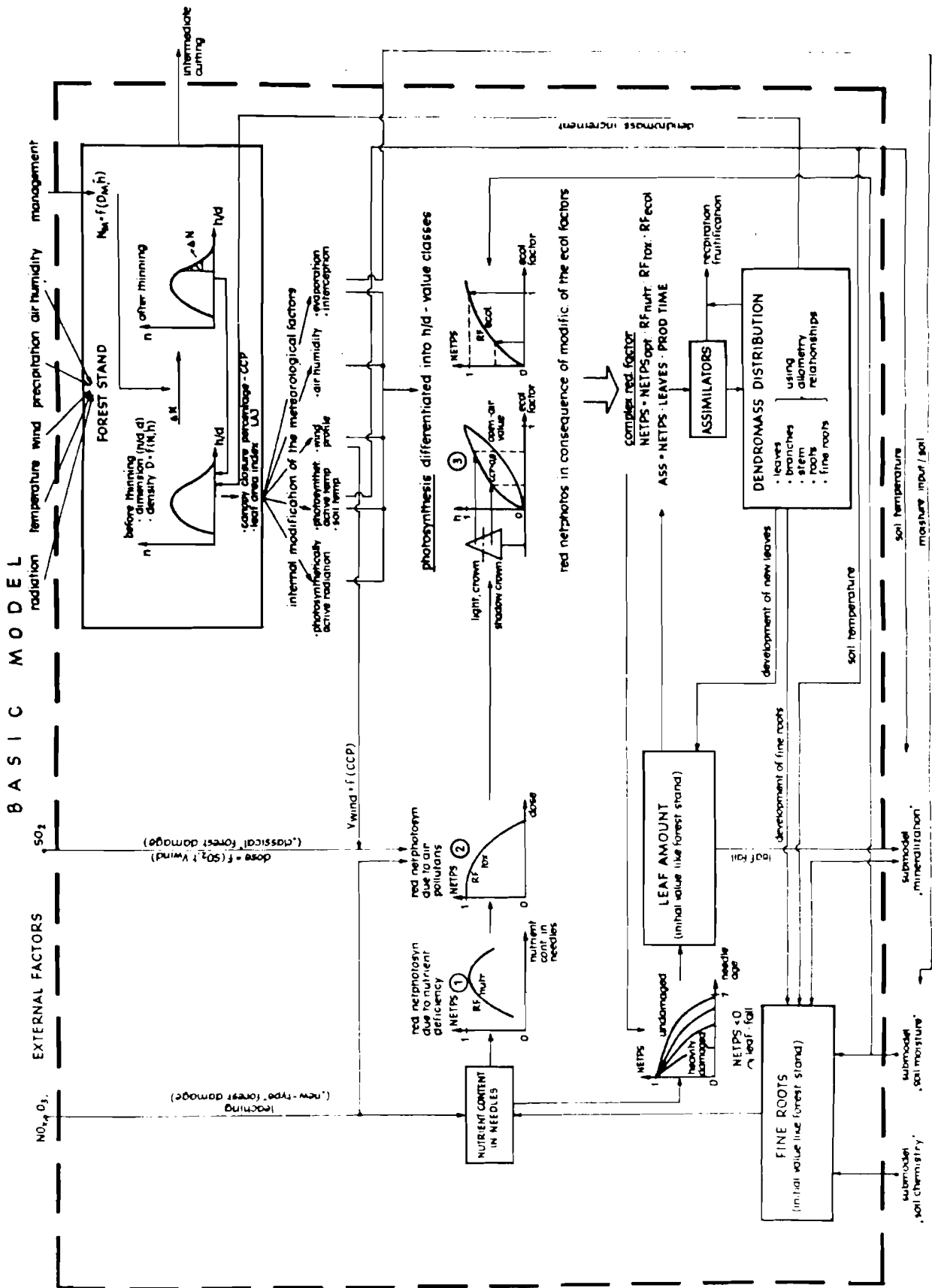

Figure 1. Basic structure of the spruce stand model.

4. FINAL REMARKS

In contrast to other models developed for similar purposes, the proposals submitted here comprise the following differences or innovations:

- (a) Bossel et al. (1985) simulation model of the dynamics of forest die-back:
 - (i) quantitative information on the regional development of forest damage as well as related to concrete stands;
 - (ii) consideration of measures serving to tend stands (ecosystem management);
 - (iii) information on the development of the biomass of individual trees and forest stands, differentiated into mean height, stem number, h/d-value distribution and dimension;
 - (iv) quantification of the influence exerted by pollutants and fertilizers over nutrient contents in needles and leaf efficiency ("classical" and "new-type" forest damage); and
 - (v) possibilities of cost optimization and comparison of effectiveness over scenarios including reduction of emissions, stand tending, and fertilization.
- (b) PEMU for pine (Bellmann et al. 1987, 1988):
 - (i) greater consideration of direct causal relationships;
 - (ii) other ways of management modeling;
 - (iii) information on the dendromass development of individual trees and stands, differentiated into mean height, diameter and h/d-distribution; and
 - (iv) quantification of the detrimental influence exerted by pollutants and fertilizers over nutrient contents in needles and leaf efficiency, differentiated into "classical" and "new-type" forest damage.

(Yield tables could not be used as a growth model, because in the case of damage development for spruce, the climate, position and stand structure absolutely must be taken into account.)
- (c) "RAINS" model of the Acid Rain Project at IIASA (Alcamo et al. 1987):
 - (i) same as under (a) above; and
 - (ii) acidification of soil is only one element of our simulation model designed to analyze the problems of forest damage in spruce.

On the other hand, it must be said that various model structures, particularly from the Bossel et al. (1985) model, have been taken over or were considered. This concerns above all the soil compartment.

When a well-functioning model of the presented design is completely developed, it will be possible to simulate fundamental processes in spruce ecology and forestry. Herefrom, important control strategies can be derived for the application of measures not only in forestry, but also in environmental management.

REFERENCES

- Alcamo, J., M. Amman, J.-P. Hettelingh, M. Holmberg, L. Hordijk, J. Kämäri, L. Kauppi, P. Kauppi, G. Kornai, and A. Mäkelä. 1987. Acidification in Europe: A simulation model for evaluating control strategies. *Ambio* 16:232-245.
- Bellmann, K., P. Lasch, N. Model, and M. Flechsig. 1987. PEMU-Luft, ein Programmsystem zur Prognose und Unterstützung von Entscheidungsprozessen im Umweltschutz (Luftschadstoffe). Forschungsbericht. Berlin: Zentralinstitut für Kybernetik und Informationsprozesse.
- Bellmann, K., P. Lasch, G. Hofmann, S. Anders, and H. Schulz. 1988. The PEMU Forest-Interpact Model Forst K. A pine stand decline and wood supply model. *Systems and Simulation, Vol. 2, Series Mathemath. Res., Vol. 47*. Berlin: Akad. Verlag.
- Bossel, H., W. Metzler, and H. Schäfer. 1985. Dynamik des Waldsterbens. Mathematisches Modell und Computersimulation. *Fachberichte Simulation 4*. Berlin-Heidelberg-New York-Tokyo.
- Flemming, G. 1986. Der Einfluss treppenartig ansteigender Waldbestände (Schlagreihen) auf die Windgeschwindigkeit in ihrer Rolle als Verstärkungsfaktor für Immissionsschäden. *Zeitschr. Meteorol.* 36:27-35.
- Grossmann, W.D. 1986. Products of photooxidation as the main factors of the new forest decline - Results and considerations. Pages 79-100 in L. Kairiukstis, S. Nilsson and A. Straszak, eds. *Forest Decline and Reproduction: Regional and Global Consequences. WP-87-75*. Laxenburg, Austria: International Institute for Applied Systems Analysis.
- Kortüm, F. 1961. Über den Einfluss der Bestockung auf den Wasserhaushalt grundwasserferner, diluvialer Sand- und Lehmstandorte. *Sitzungsberichte* 10(11). Berlin: Dt. Akademie d. Landwirtschaftswissenschaften.
- Kraft, G. 1884. *Beiträge zur Lehre von Durchforstungen, Schlagstellungen und Lichtungshieben*. Hannover.
- Rosemeier, G.E. 1976. *Winddruckproblem bei Bauwerken*. Berlin.
- Tirén, K. 1929. Einige Untersuchungen über die Schaftform (Meddelanden fran Statens Skogsforsöksanst.) *Mitt. aus d. Versuchsanst. Schweden* 24:81-152.

APPENDIX I

Quantification of the following relationships has been worked out:

- a) Variation of the dry matter of needles, branches, stems, and roots with the h/d-value and $d_{1,3}$.

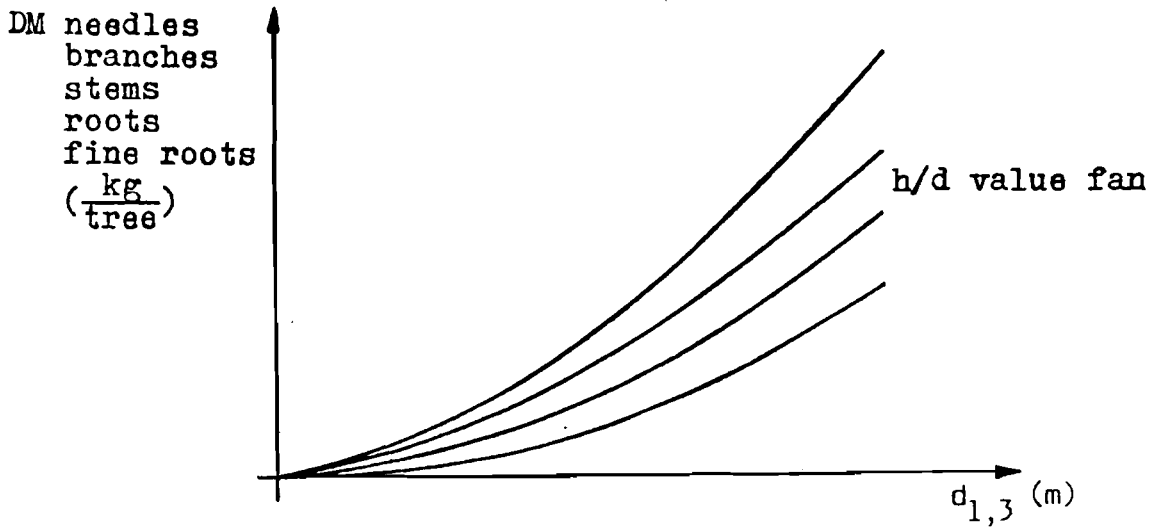

- b) Relative dendromass distribution of the components needles, branches, stems and roots in dependence on the h/d-value and $d_{1,3}$.

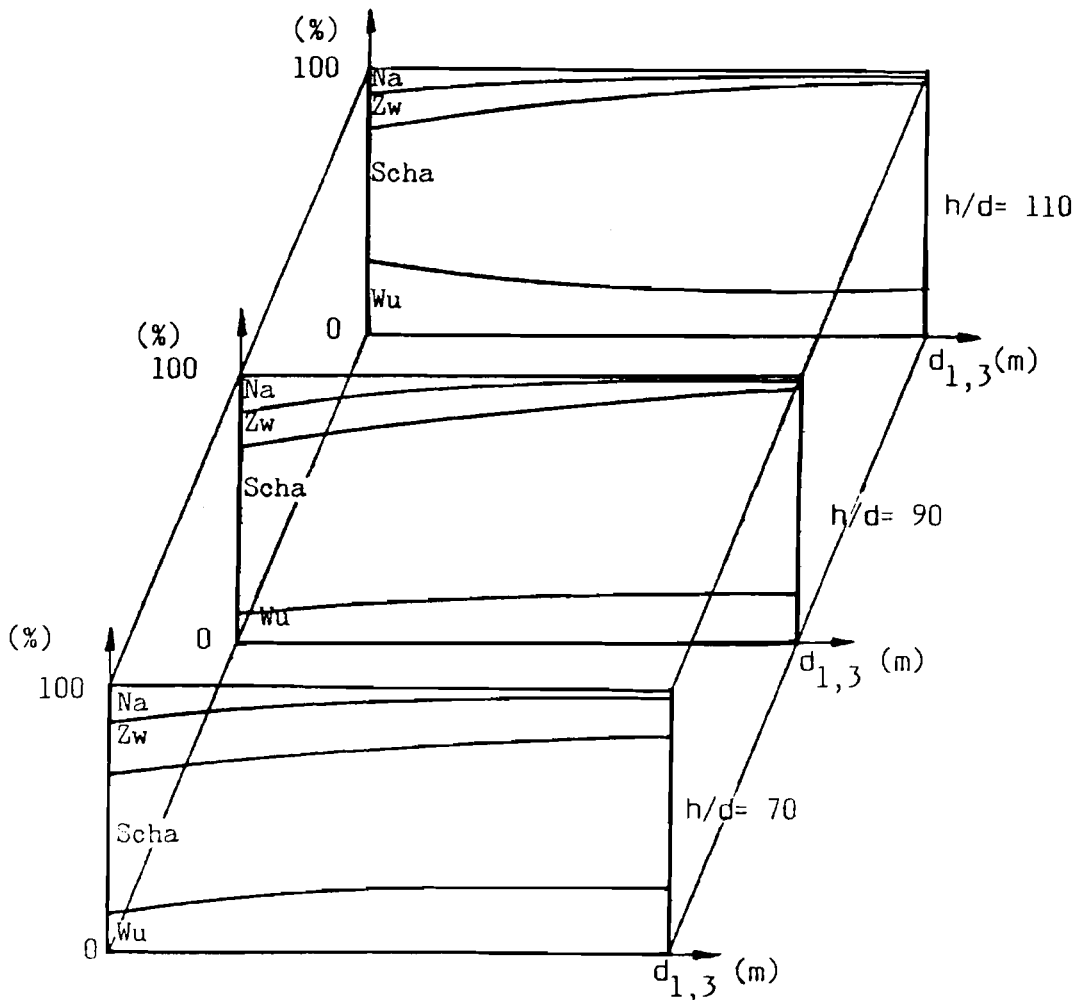

- c) h/d -value distribution for stands with a top height $h_0 = 15$ m in dependence on the stem number of the initial stand (remaining stand after young growth tending as a starting value for submodel 1).

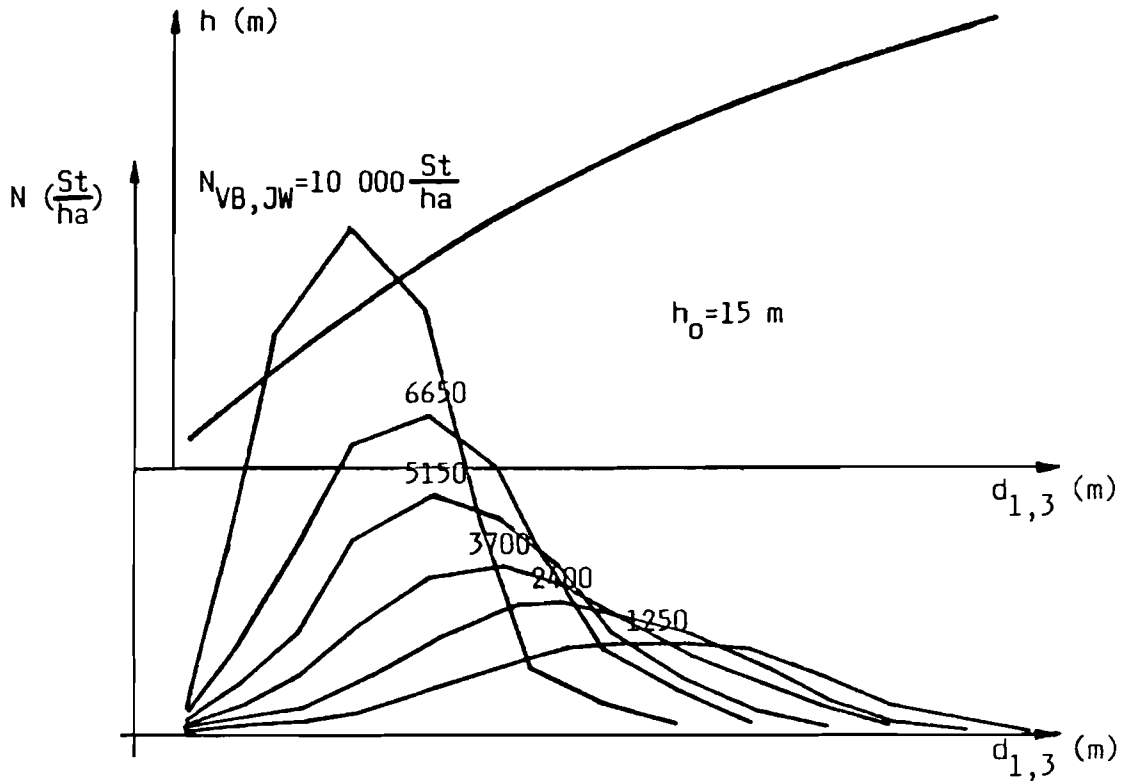

- d) Parameter of the Weibull-distribution.

