

SOME QUESTIONS ON HARDWARE STRUCTURE  
OF THE INTEGRATED SYSTEMS CONTROL

German Surguchev

June 1975

WP-75-71

Working Papers are not intended for distribution outside of IIASA, and are solely for discussion and information purposes. The views expressed are those of the author, and do not necessarily reflect those of IIASA.

## Foreword

The hardware structure of the integrated systems control (ISC) is defined by many factors, for example, the structure of the controlled systems, the functions of ISC, the computer systems already existing, the economic situation and so on.

I would like to discuss some of these problems taking the steel industry as an example.

---

## Generalization

The hardware structure of an integrated systems control (ISC) must support the functions which are carried out by the ISC. This idea seems to be very simple at first sight though it has many aspects and difficulties. It is quite possible to formulate several general objectives for the ISC hardware. They are the following:

- to implement all functions which make up the ISC;
- to be constructed in a hierarchical structure;
- to ensure effective data input, output, processing and storage;
- to take into consideration the possibilities of development and improvement.

Hardware problems will be discussed with these remarks in mind.

The first question to be discussed is what kind of general hardware structure should be used? In this case we must consider two different alternatives:

- use of one or more large-capacity computers to solve the tasks for all the control levels; and
- use of a number of mini- or medium-sized computers at individual levels.

We consider an "ideal" hardware structure in terms of these alternatives and certainly we accept the terms "ideal" rather conditionally.

As an "ideal" hardware structure we imply a kind of structure which makes up the ISC function in each level. In this case each level of the ISC must be supported by specialized hardware systems and must use one or more computers per functional level. The number and size of the computers, peripherals and all technical means correspond to the function to be fulfilled at that level.

An example of an "ideal" hardware structure is given in Fig. 1. Such an approach using one or more computers for each functional level helps keep lines of responsibility clear.

A number of steel works are now moving in the direction of minimizing the hardware hierarchy by combining two or more functional levels into one. Some works replace the existing multi-computer four-level hierarchies by a two-level approach.

---

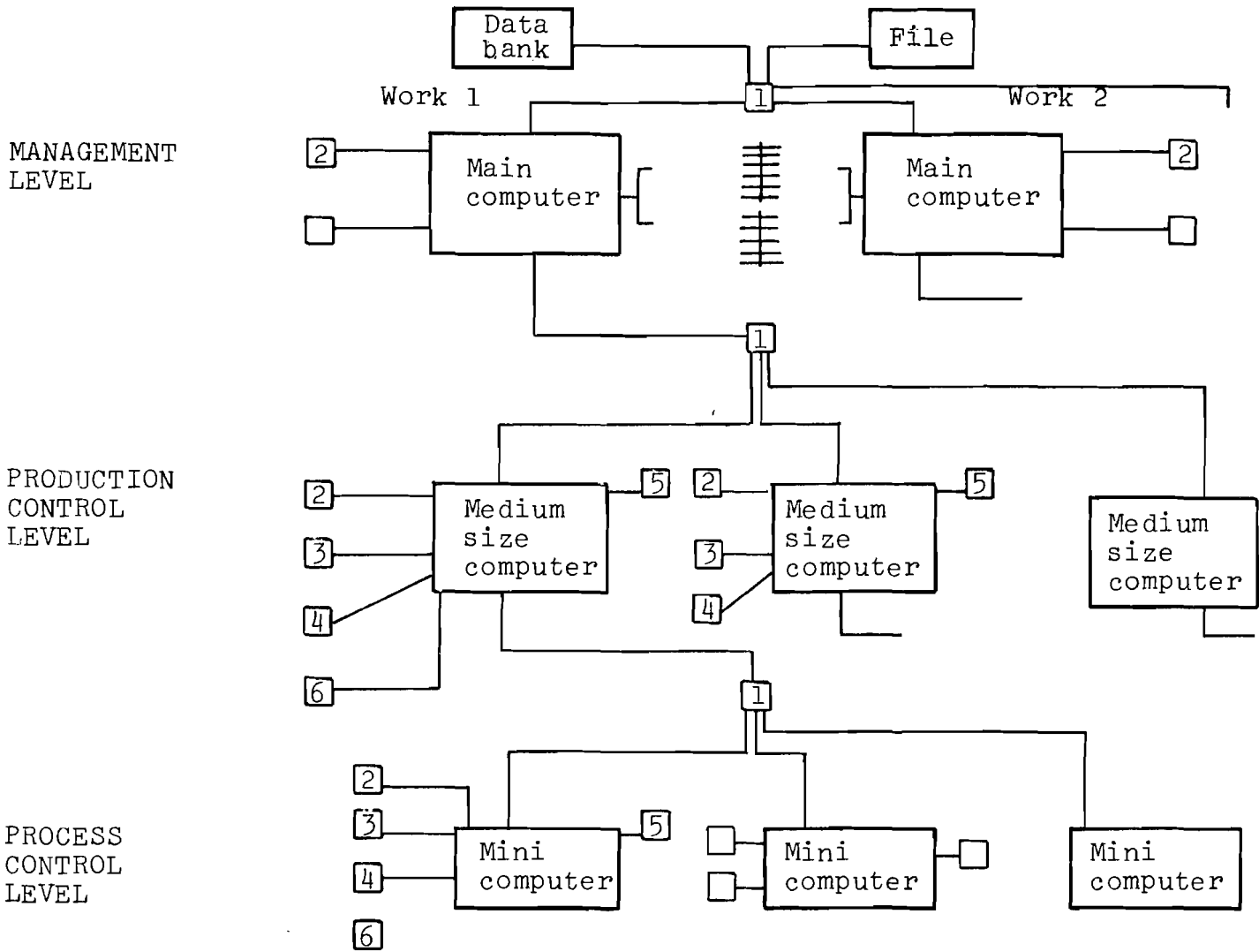
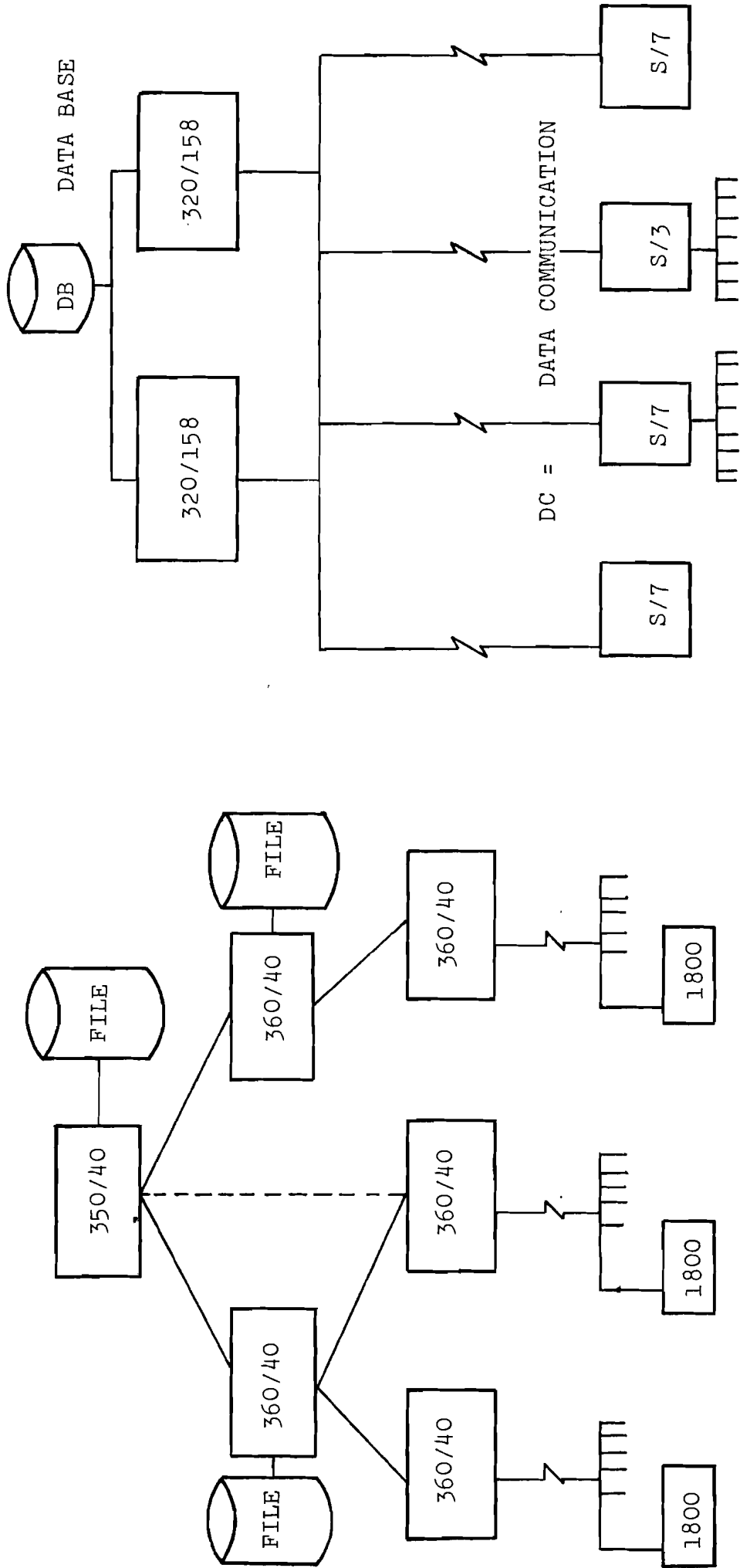

Fig. 1 "Ideal" hardware structure

4 LEVEL CONFIGURATION

2 LEVEL CONFIGURATION  
LARGE AND SMALL SYSTEMS

MEDIUM SIZE SYSTEMS



CENTRALIZED SYSTEM

Fig. 2 Change in the ISC hardware configuration. DISTRIBUTED SYSTEM

Figure 2 shows this change in configuration from several medium-sized systems to two large and a number of small, remote computers. The configuration is called a distributed system. By implementing a modular structure of hardware, this problem lessens. Modular structure has several advantages, some of which are the following:

- system flexibility (changing the functional structure, evaluation possibilities);
- higher reliability;
- higher economical efficiency.

Hardware redundancy can be a disadvantage of a modular structure, but this redundancy is compensated by the benefits to be received. Special features of hardware structure for each control level are discussed below.

#### Process Control Level Hardware

The control tasks of separate technological units or processes determine the hardware structure in the process control level. The hardware in this level is working on-line, and the reliability demands of the systems are very high.

The following special hardware features are characteristics for this particular level:

- implementation of a number of mini computers connected with the next production control level;
- implementation of specialized sensors, specialized manual input devices, indicating panels, and so on; and
- difficult conditions for the hardware in this level (high temperature, dust, dirt, and so on).

The implementation of minicomputers gives us the opportunity to organize an independent control for each technological unit. Mini computer systems have a number of other benefits, some of which are the following:

- flexible systems structure, which presents the possibility of modifying, replacing or deleting a part of the system without upsetting the rest of the system;
- graceful degradation-failure in one or more components does not cause the entire system to fail; and
- high systems' reliability due to the parallel working of redundant units and subsystems, and so on.

The cost of these systems is quite low due to the simplified hardware, software and the multiple use of standard components (many different subsystems can use identical hardware to perform varied functions). The hardware in the process control level, as in the other levels, has one special feature: almost all steel companies started designing an ISC with computers working on one level. These computers were installed individually without considering the future development of a fully integrated control system. However, the hardware in the process control level, as in other levels as well, influences the hardware structure of the integrated systems as a whole.

It is quite likely that one of the biggest problems in the hardware structure is the linking of the process-control computers, which have been developed as separate, independent systems, with computers in other levels. In this case by developing the system the same type of the computer or special communication units can be used. The implementation of the hardware modular structure gives more possibilities to link the computer in other levels.

#### Production Control Levels Hardware

The hardware structure in the production control level is also determined by the required functions. The production control level systems work in real time. The tasks to be solved in this level include material flows, stock control, compilation of reports, and so on. These tasks demand medium-sized computer storage and an expensive peripheral system. It is significant that, at this level, not only standard computer peripheral systems are being implemented, but also sensors, specialized manual input devices and indicating panels. These specialized peripherals are a particularly important part of hardware here. At this level computer storage capacity can be limited since the complete data bank can be located in the main computer storage.

#### Higher Levels of the Hardware

Large computers are generally needed for solving the tasks of the higher hierarchical levels (management information tasks, planning/scheduling, order processing, and so on). The hardware of all the integrated systems control we have already studied has a structure similar to these higher levels. Such big modern computers as an IBM-370, AEG-60-50 and others have been installed

A general problem of hardware of the production control level is to secure an efficient man-machine dialogue for decision-making. Special features of the hardware can be characterized as follows:

- application of the large-sized computers;
- application of standard peripheral devices (terminals, displays, and so on).

The tasks being solved in this level can be connected with the operative planning-scheduling problems. In this case losses from systems unreliability can be quite high. One of the functions of the main computer is a supervisory role over the lowest levels of the hardware, through which the reliability of the system is increased.

Modern steel companies have geographically separated locations, and individual works can be located hundreds of kilometers apart. Each works has its own computer center to fulfill the high level tasks. The development of computer networks between separate high-level computers is an important task in this case. A high capacity network permits the transformation of geographically separated computers into one logical computer center.

#### Limits of Growth of the ISC Hardware and Their Reliability

A very important question concerns the estimates of storage volume needed for an ISC in the steel industry. The storage volume depends on:

- the structure of steel production enterprises;
- the tasks to be solved by the ISC for the functional structure of the ISC;
- the general productivity and a number of types and sizes of products;
- the hardware structure of the ISC.

Estimates of such items have been made in Figure 3. These results are for a steel plant which has capacity about 500000 tons steel/year. It is clear that this characteristic is not enough for an accurate determination of the storage volume. The more important indication, which Figure 3 gives us is that the largest quantity of data is generated at the rolling mills.

The storage volume and size of other hardware determine the reliability of a system. The guarantee of the reliability of such a system becomes an important, complicated problem if we expand the function of the ISC and increase the hardware



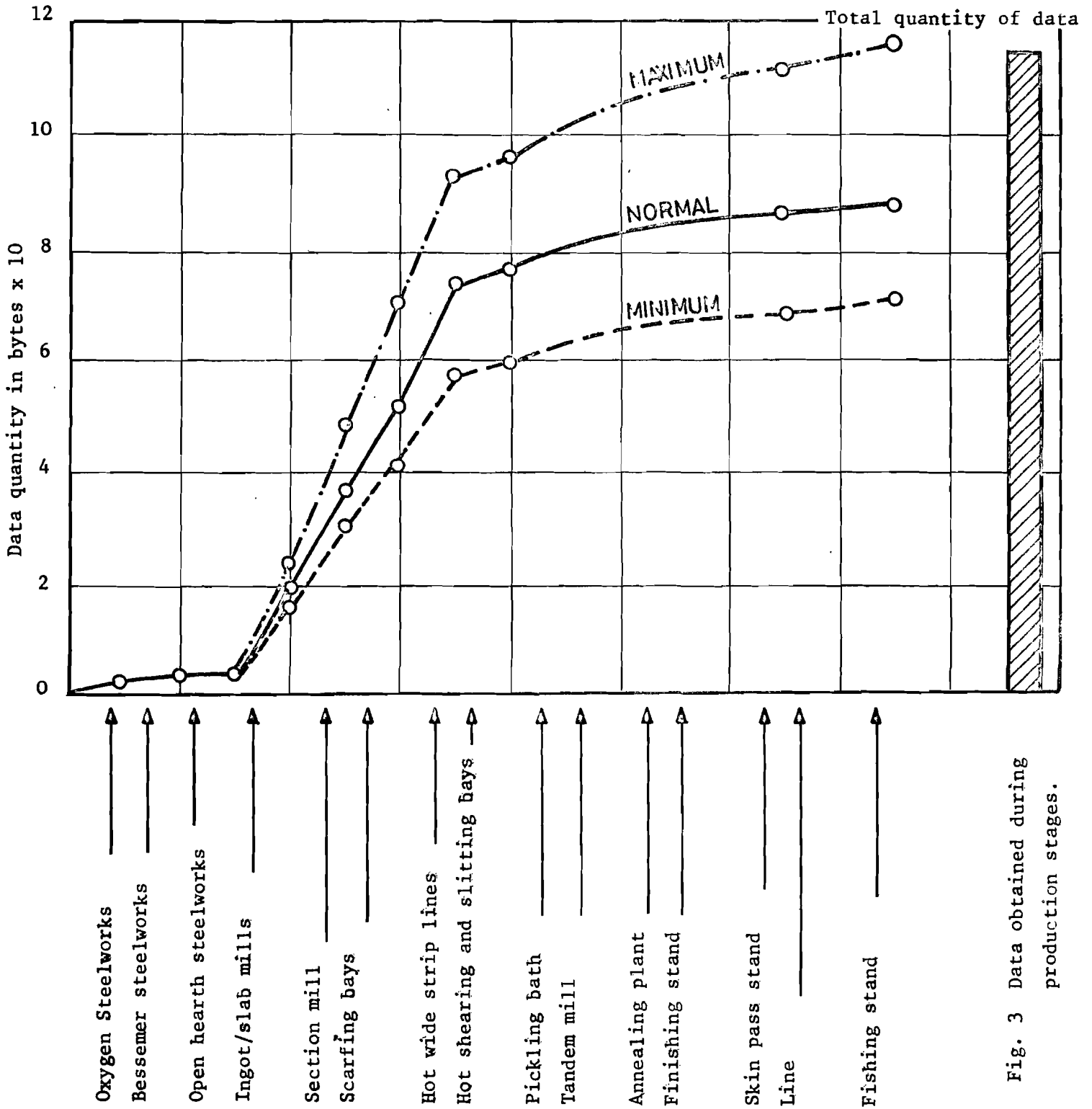

Fig. 3 Data obtained during production stages.

capacity. High hardware reliability is limited by the cost of a system.

There are at least two ways of increasing the reliability of the systems: 1) increasing of the reliability of each element of the hardware system, and 2) in the organization of a system's reservation.

The first is a general problem of computer industry and a real way of improving the reliability of designed ISC is reservation.

There are two possibilities of reservations:

- element reservation (parallel switching of hardware elements); and
- time reservation (foreseeing the redundant hardware capacity).

The question of reliability/cost is rather important. Although the low levels of hardware working on-line must have high reliability, the losses from mistakes made in the high levels, due to low reliability there, can be larger and the consequences more widespread than in lower levels. No examples of the quantitative estimates of reliability/cost problems in hardware in the steel industry can be given. And only quantitative remarks can be made.

#### Classification of Hardware for the ISC

We divide all the hardware elements implemented by the ISC into five parts (Figure 4):

- information acquisition;
- data transmission;
- data processing and data storage;
- information output and display; and
- local dispatching control systems.

Because the problems of standard computer hardware are well-known, there is no need to discuss there. Solutions are being continuously sought by the industry.

We intend to discuss the problems and difficulties which the steel industry has. One of the problems in the steel industry concerns sensors.

---

Sensors are of great significance for process and production

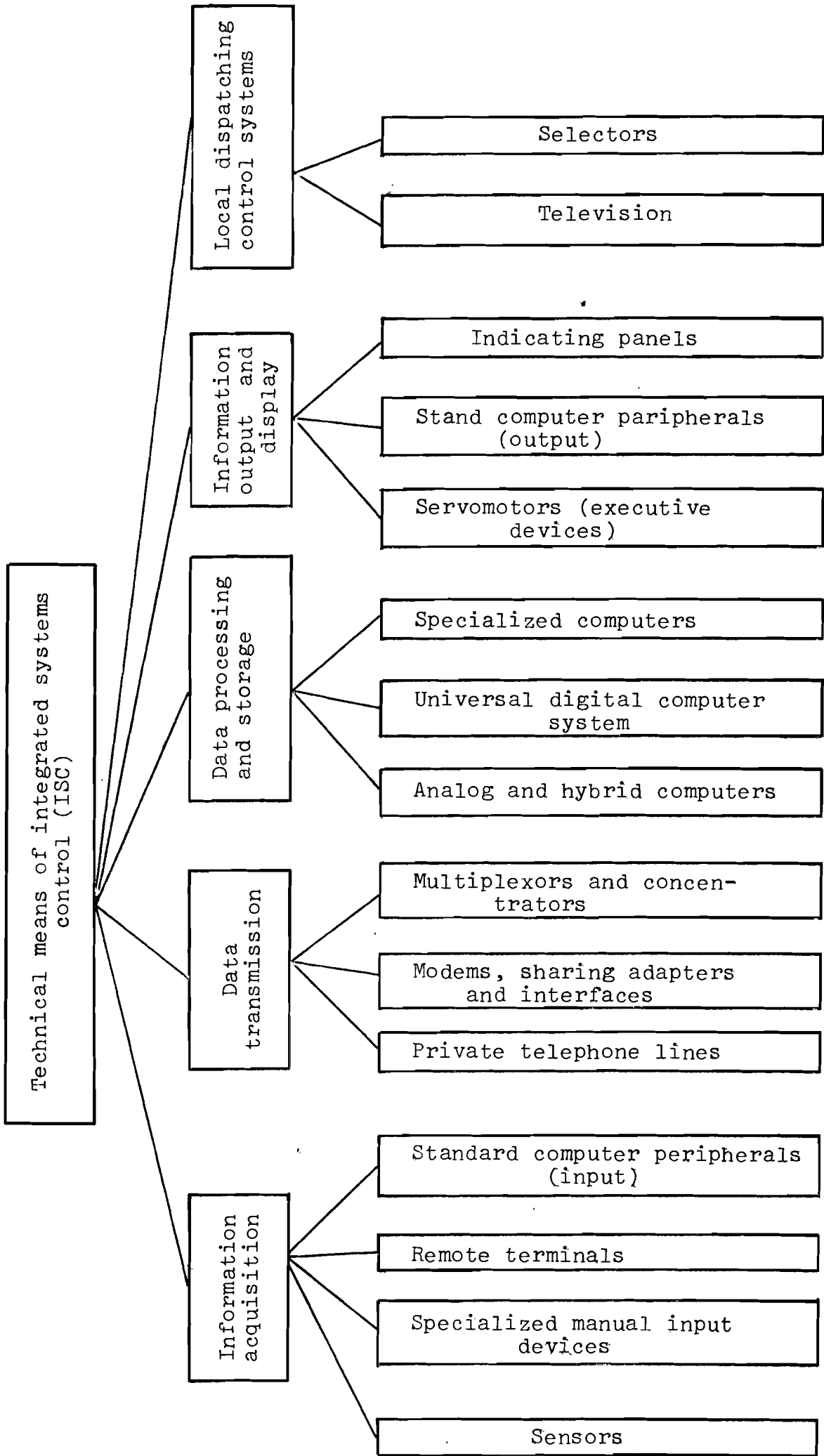

Fig. 4. Classification of technical means of integrated systems control.

control levels. It is not possible in steel industry, for example, to obtain continuous information about the composition of the elements in metal and slag, information about the temperature, rolling speed, thickness of slabs, position of the cranes and so on.

There are several methods for measuring these variables, but the main problem is to receive continuous and reliable information in the steel plants under hard working conditions and to input this information to computer systems. It is known that sensors do not work particularly reliably in steel industry. The unavailability of sensors for measurement of basic parameters, or/and the unreliability of those available are primary problems encountered when putting control systems into operation.

Specialized manual input devices are employed in process and production control levels. These devices are designed by separate companies in conformity with their problems and special features. Implementation of these devices is a consequence of the lack of methods for and devices of measurement for a number of variables.

Data transmission hardware as a rule is standard. The development of the integrated computer network for large companies possessing several plants is a problem as well. It is possible for them to develop their own special communication means or to use private telephone lines.

Data processing devices are also standard. The most important problem is the choice of storage size as mentioned above.

Information output and display devices have several special features. In addition to standard computer peripherals, the specialized indicating panels are servomotors (operating devices) and are included in this group. The indicating panels have a different function and, therefore, a different structure as well. They can be installed in each control level, but are more frequently installed in process or production control level.

Dispatching control systems are necessary to mention, since they can either be connected with the ISC or can work as a separate part of the system. As a general rule, these systems are developed on the basis of standard elements.

## Conclusion

This study of the existing ISC systems permits several conclusions:

- (1) There is only one possible method of solving high level

tasks and that is to employ a large computer with a large storage capacity.

- (2) For the lowest levels it is more economic to implement systems based on mini computers.
- (3) There are several opportunities to organize the hardware in middle (production control) levels on the basis of large, medium or mini computers.
- (4) The modular hardware structure increases the flexibility, reliability and economic efficiency of the systems.
- (5) The elements and the time reservations give us the chance to increase systems reliability, and this is connected to system cost.
- (6) There are some difficulties in developing the ISC hardware, for example:
  - (a) there are not enough input devices, sensors, to allow recording of all the information needed for an ISC;
  - (b) links between the lower and higher levels of hardware are being developed individually without considering the development of a fully integrated system;
  - (c) it is difficult to calculate or to estimate the economic efficiency of the ISC.

#### REFERENCES

- 1 Kirschgaesser, H.A. and Gilhert, C. "Data Processing in the Steel Industry: The State of the Art and Trends in Computer Applications." Third International Symposium on the Iron and Steel Industry. Brasilia, Brasil, October 14-21 1973.
- 2 Williams, Th. "Systems Engineering of Hierarchy Computer Control Systems for Large Steel Manufacturing Complexes." Purdue University, West Lafayette, Indiana, 1974.
- 3 Wissel, H. "The Development and Practice of Applying Mechanical Data Processing Techniques to Technical Problems in a Steel Works." "Steel and Iron," 89, 1969, No.6, pp.290-304.
- 4 Belostotsky, A., Chukhman, V. "Investigation and Organization of Production while Compiling Automated Control Systems." Metallurgy, Moscow, 1971.
- 5 Kopelovich, A., Knotek, M., Belostotsky A., Rajevich, S. "Automated Control System for a Steelmaking Plant." Metallurgy, Moscow, 1973.