

Interim Report

IR-99-046

Qualitative Identity of Real and Synthetic Data via Dynamical Model of Optimal Growth

Sergey Reshmin (reshmin@ipmnet.ru)

Approved by

Arkadii Kryazhimskii (kryazhim@iiasa.ac.at)

Senior Research Scholar, Dynamic Systems Project

September 1999

Contents

Introduction	1
1 Aggregated Data on Japanese Economy	1
2 Description of the Model and Theoretical Framework	4
3 Algorithm of Calculation of Trajectories	6
4 Clusters of Theoretically Optimal Scenarios and Empirical Data Series	10
5 Appendix: Accuracy Estimation	15
References	17

Abstract

A dynamical model of optimal economic growth is used for the comparison of catalogues of real econometric data and synthetic growth scenarios. The model is calibrated on a database of the Tokyo Institute of Technology. A special attention is paid to the aggregated data of the Japanese manufacturing industry in period 1955-1992. A description of an algorithm of modeling optimal trends in the technological dynamics is given. The work has been performed within the framework of the joint research program of IIASA and the Tokyo Institute of Technology on *Comparative Analysis of the Endogenous Techno-economic Process: Technology Spillovers in Japan, the USA, Europe and APEC Countries*.

About the Author

Sergey Reshmin is a postgraduate student at the Institute of Physics and Technology, Russian Academy of Sciences, 117526 Moscow, Russia. The paper presents his results obtained during the IIASA Young Scientists Summer Program of 1999.

Acknowledgment

I would like to thank Arkadii V. Kryazhinskii and Alexander M. Tarasyev for their assistance and helpful comments. My thank also goes to Chihiro Watanabe for his advise on empirical data.

Qualitative Identity of Real and Synthetic Data via Dynamical Model of Optimal Growth

Sergey Reshmin

Introduction

This paper applies a mathematical model of optimal economic growth proposed and explored in [Tarasyev, Watanabe, 1999] for the numerical analysis of real econometric data. The model involves production and technology (the accumulated R&D investment) and is associated with a problem of optimal R&D investment in a techno-metabolic system. The model reflects two basic trends in the manufacturing and the R&D investment. On the one hand the accumulated R&D investment (technology) stimulates the growth of the firm's output, on the other hand, the R&D investment draws resources from manufacturing. The model takes into account the both trends. A theoretical analysis of the model resulted in a description of an optimal R&D investment policy with respect to a standard utility function given in [Grossman, Helpman, 1991].

In this paper the main attention is paid to a comparison of model-based scenarios and empirical time series. The underlying theoretical problem is to find optimal synthetic growth scenarios in which an optimal balance between production and the R&D investment is maintained. Due to the unstability of the optimal equilibrium it is rather difficult to find exact optimal trajectories numerically. We propose a numerical algorithm for modeling suboptimal trends in the technological dynamics and prove that the suggested quasioptimal control law is arbitrarily close to optimal (an analytical estimate of the error is given).

The model is calibrated on the aggregated data on the Japanese manufacturing industry with sensitivity analysis. The calibration procedure employing elements of the sensitivity analysis adjusts the model to the qualitative trends in the empirical time series for technology, production and technology productivity. It is shown that the synthesized optimal growth scenarios can agree well with the empirical time series. This fact agrees with a conjecture that the economic development in Japan was theoretically close to optimal in period 1970-1992. The econometric data used for the model calibration have been published in [Watanabe, 1995].

1 Aggregated Data on Japanese Economy

In this section the aggregated data on the Japanese manufacturing industry in period 1955-1992 are demonstrated. Fig. 1 illustrates trends in production y . The production magnitude is measured in billion yens. Looking at the Figure, we see

that production is growing practically exponentially. At the first glance the curve is sufficiently smooth.

Fig. 2 shows growth in technology (or accumulated R& D investment) T . Its character is approximately the same.

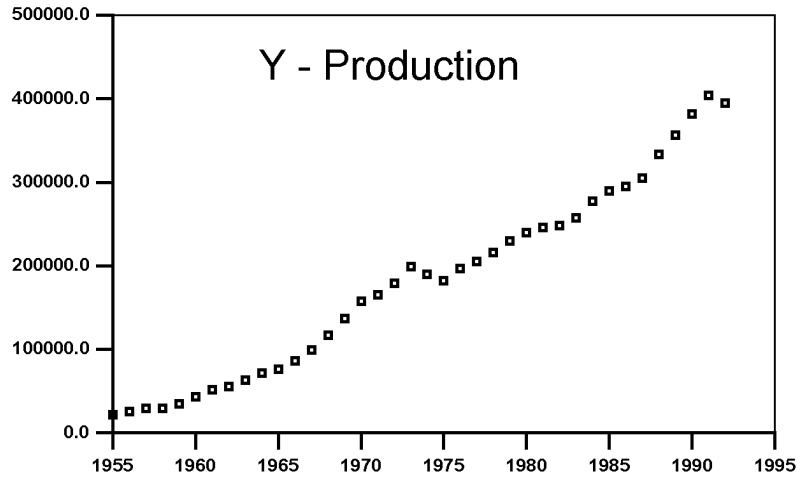

Fig.1 Trends in production in the Japanese manufacturing industry (1955-1992) (billion yens)

Source: Tokyo Institute of Technology
(data over the period 1955-1970 are under review)

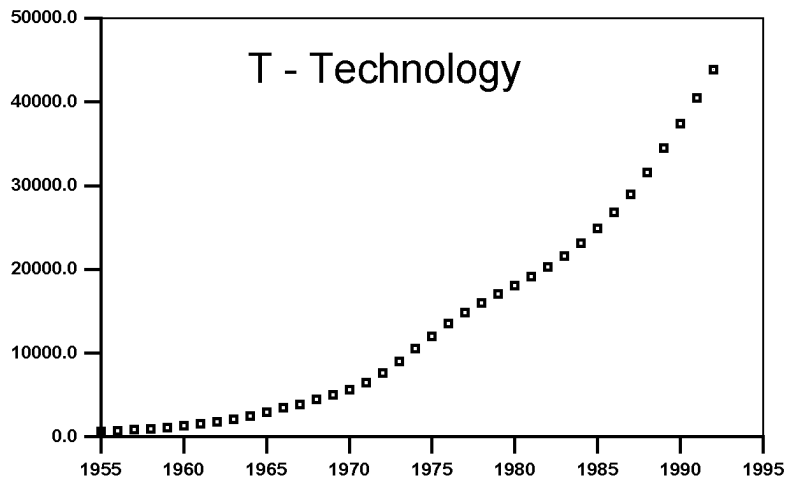

Fig.2 Trends in technology knowledge stock in the Japanese manufacturing industry (1955-1992) (billion yens)

Source: Tokyo Institute of Technology
(data over the period 1955-1970 are under review)

Fig. 3 illustrates trends in technology productivity y/T . We see that the behavior is more complex. We obviously see a threshold around 1970. Why does it happen? The economists explain this by an energy crisis and strong constraints in labor during the rapid economic growth period in the 1960s [Watanabe, 1995]. We see that in this period the process is practically stochastic and poorly controllable. At the beginning of the 1970s the Japanese government made serious efforts to correct this crisis situation. The economic behavior became more regular.

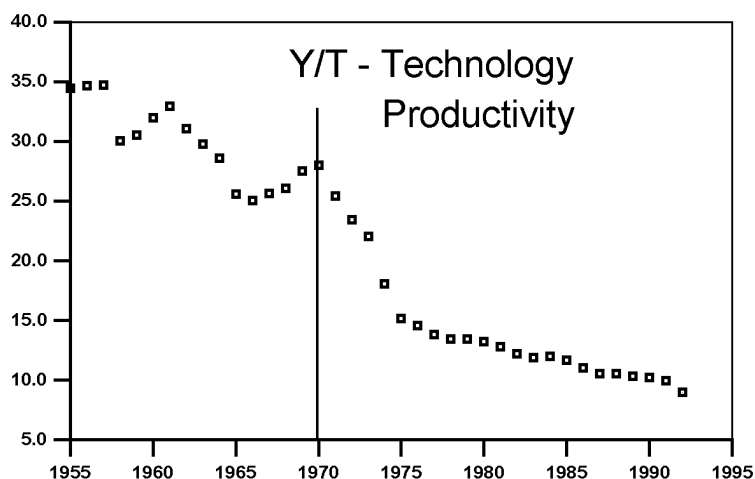

Fig.3 Trends in productivity of technology in the Japanese manufacturing industry (1955-1992)

Source: Tokyo Institute of Technology
(data over the period 1955-1970 are under review)

Due to the programs supported by the Japanese government the economy became more manageable and more efficient. One might guess that in period 1970-1992 the economic policy was close to optimal. A goal of this paper is to support this hypothesis by comparing the real econometric data and mathematically justified optimal growth scenarios. For this identification, we use a nonlinear system of differential equations describing the technological dynamics. A brief description of the model is given in section 2. A numerical algorithm for designing optimal growth trajectories is described in section 3. Examples of optimal growth scenarios and a comparison with empirical time series are presented in section 4.

2 Description of the Model and Theoretical Framework

The model suggested and analyzed in [Tarasyev, Watanabe, 1999] is described by the system of two equations

$$\frac{\dot{y}}{y} = f_1 + f_2 \left(\frac{T}{y} \right)^\gamma - g \frac{r}{y}, \quad (2.1)$$

$$\dot{T} = r.$$

These equations show the balance between the productivity rate \dot{y}/y and R&D intensity r/y . The term $f_2 \left(\frac{T}{y} \right)^\gamma$ characterizes the impact of the accumulated R&D investment T on production y . The term f_1 represents a non-R&D contribution. The negative sign in front of the net contribution of R&D $g \frac{r}{y}$ means that in the short-run spending into R&D prevails upon the rate of return to R&D, which is a risky factor in R&D investment.

The production y and accumulated R&D investment T are the phase parameters of the system. The current change r in technology T is the control parameter. The control parameter r is not fixed and can be updated in time for obtaining 'good' properties of the trajectories. The problem is to find an optimal technology rate r as a function of time. The optimality is understood with respect to the utility function U_t represented by an integral with a discount coefficient ρ (see, for example, [Arrow, 1985], [Arrow, Kurz, 1970], [Grossman, Helpman, 1991]):

$$U_t = \int_t^\infty e^{-\rho(s-t)} \ln D(s) ds, \quad (2.2)$$

$$D = D(s) = \left(\int_0^n x^\alpha(j) dj \right)^{1/\alpha}, \quad (2.3)$$

$$x(j) = \frac{y}{n}, \quad n = n(s) = b e^{\kappa s} T^{\beta_1} r^{\beta_2}, \quad (2.4)$$

$$y = y(s), \quad T = T(s), \quad r = r(s). \quad (2.5)$$

Here $D(s)$ is the consumption index, s is the running time, t is the initial time, j is the current index of invented products, $x(j)$ is the quantity of production of the brand with index j , n is the quantity of available (invented) products, α , β_1 , β_2 are the elasticity coefficients. Note that D depends on production, technology and current investment.

Combining (2.2)-(2.5) and omitting constant term independent on y , T and r one can obtain the following expression for the utility function:

$$U = \int_t^\infty e^{-\rho(s-t)} (\ln y + a_1 \ln T + a_2 \ln r) ds. \quad (2.6)$$

Here

$$a_1 = A\beta_1, \quad a_2 = A\beta_2, \quad A = \frac{(1-\alpha)}{\alpha}.$$

The considered problem is a classical problem of the optimal control theory. The Pontryagin's maximum principle is a key instrument in the theory (see [Pontryagin, et. al., 1962]). Applications of this optimality principle to problems of economic growth were developed in [Arrow, 1985], [Arrow, Kurz, 1970]. The main element in the analysis are the Hamiltonian H and the adjoint variables ψ_1, ψ_2 . The Hamiltonian has the form

$$H(y, T, r, \psi_1, \psi_2) = \ln y + a_1 \ln T + a_2 \ln r + \psi_1(f_1 y + f_2 T^{(1-\gamma)} - gr) + \psi_2 r \quad (2.7)$$

and represents the utility flow. The adjoint variables act as marginal prices. The maximum value of the Hamiltonian is attained at the current optimal technology rate

$$r^0 = a_2 \frac{1}{g\psi_1 - \psi_2}. \quad (2.8)$$

The optimal dynamics is given by the following differential equations:

$$\begin{aligned} \dot{x}_1 &= f_1 x_1 + f_2 x_1^{(1-\gamma)} - \frac{a_2(x_1 + g)x_1}{(gx_2 - x_1 x_4)}, \\ \dot{x}_2 &= \rho x_2 + \gamma f_2 x_2 \frac{1}{x_1^\gamma} - 1 - \frac{a_2 g x_2}{(gx_2 - x_1 x_4)}, \\ \dot{x}_3 &= -\frac{a_2 x_1 x_3}{(gx_2 - x_1 x_4)}, \\ \dot{x}_4 &= \rho x_4 - \gamma f_2 x_2 \frac{1}{x_1^\gamma} - a_1 + \frac{a_2 x_1 x_4}{(gx_2 - x_1 x_4)}. \end{aligned} \quad (2.9)$$

Here x_1, x_2, x_3, x_4 are new variables connected with the original and adjoint variables:

$$x_1 = \frac{y}{T}, \quad x_2 = \psi_1 y, \quad x_3 = \frac{1}{T}, \quad x_4 = \psi_2 T. \quad (2.10)$$

A typical optimal trajectory plotted in Fig.4. exhibits growth in production and technology, and decline in productivity of technology.

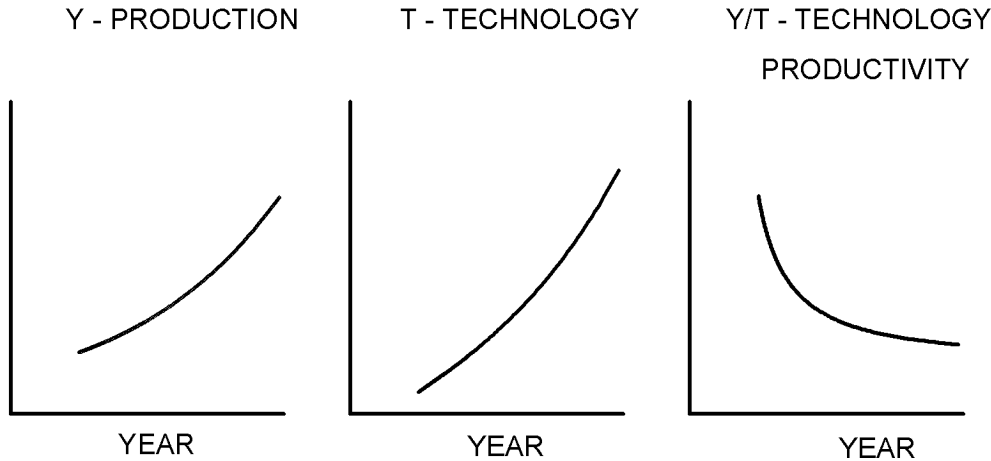

Fig.4 A typical optimal trajectory

The following results for system (2.9) were proved in [Tarasyev, Watanabe, 1999].

1) System (2.9) has the first integral

$$z = \psi_1 y + \psi_2 T = p^0 = \frac{a_1 + a_2 + 1}{\rho}. \quad (2.11)$$

2) Thanks to this first integral the four-dimensional system (2.9) is reduced to the next three-dimensional system whose two variables, x_1 , x_2 , do not depend on the third one, x_3 :

$$\begin{aligned} \dot{x}_1 &= f_1 x_1 + f_2 x_1^{(1-\gamma)} - \frac{a_2(x_1 + g)x_1}{((x_1 + g)x_2 - p^0 x_1)} = F_1(x_1, x_2), \\ \dot{x}_2 &= \rho x_2 + \gamma f_2 x_2 \frac{1}{x_1^\gamma} - 1 - \frac{a_2 g x_2}{((x_1 + g)x_2 - p^0 x_1)} = F_2(x_1, x_2), \\ \dot{x}_3 &= -\frac{a_2 x_1 x_3}{((x_1 + g)x_2 - p^0 x_1)} = F_3(x_1, x_2, x_3). \end{aligned} \quad (2.12)$$

3) Under several natural assumption system (2.9) has the unique equilibrium point $x^0 = (x_1^0, x_2^0, x_3^0)$, $x_1^0 > 0$, $x_2^0 > 0$, $x_3 = 0$, which is a saddle. All optimal trajectories converge to x^0 .

3 Algorithm of Calculation of Trajectories

It should be noted that in a numerical aspect, the problem of finding an optimal trajectory $x^0(\cdot)$ which leads system (2.12) to the saddle point x^0 is very complicated due to the instability of this equilibrium. In this section a constructive numerical procedure for finding a quasioptimal control which leads coordinates $x_1(\cdot)$, $x_3(\cdot)$ of the system to the equilibrium coordinates x_1^0 , x_3^0 is presented. Later it will be shown that the proposed quasioptimal control is arbitrarily close to optimal (see Appendix).

Suppose all parameters of the model, initial time t^0 , initial production $y(t^0)$ and initial technology $T(t^0)$ are fixed and besides, an accuracy parameter ϵ is given (see Table 1). Then the components x_1^0 , x_2^0 of the equilibrium point of the reduced system (2.12) are found from $F_1(x_1, x_2) = 0$, $F_2(x_1, x_2) = 0$.

Consider the ϵ -neighborhood of the point (x_1^0, x_2^0) in the (x_1, x_2) -plain (see Fig.5). We shall study the behavior of the coordinates x_1 , x_2 separately from x_3 due to the block structure of system (2.12).

Let us fix some point (x_1^*, x_2^*) lying in the above ϵ -neighborhood on the beam, which originates at (x_1^0, x_2^0) and goes parallel to the eigenvector corresponding to the negative eigenvalue of the Jacobi matrix

$$D = \begin{pmatrix} \partial F_1(x^0)/\partial x_1 & \partial F_1(x^0)/\partial x_2 \\ \partial F_2(x^0)/\partial x_1 & \partial F_2(x^0)/\partial x_2 \end{pmatrix}. \quad (3.1)$$

Table 1: Inputs of the Calculation Procedure

Parameters of the model
α - parameter of elasticity, ρ - discount rate, β_1 - elasticity coefficient, β_2 - elasticity coefficient, f_1 - parameter describing the non-R&D contribution, f_2, γ - parameters describing the impact of technology on production, g - discounted marginal productivity of technology
Initial conditions
t^0 - initial instant, $y(t^0)$ - initial manufacturing production, $T(t^0)$ - initial accumulated R&D investment (technology),
Accuracy input
ϵ - a small positive parameter

The process of finding a suboptimal trajectory has two stages.

At the first stage we find a trajectory of system (2.12) which passes through a point $x^* = (x_1^*, x_2^*, x_3^*)$ where x_3^* is not fixed and will be specified later. We do this in three steps presented in Table 2. We consider values $x_1 = x_1^*$, $x_2 = x_2^*$ as final and integrate the system of the first two equations in (2.12) in reverse time until $x_1(t^0) = y(t^0)/T(t^0)$; this condition determines the duration t^* of the integration process. As a result, functions $x_1(t)$ and $x_2(t)$ ($t^0 \leq t \leq t^0 + t^*$) are obtained. We substitute $x_1(t)$ and $x_2(t)$ into the third equation in (2.12) and integrate it in direct time with the initial condition $x_3(t^0) = 1/T(t^0)$. As a result, we obtain the inverse of technology $x_3(t) = 1/T(t)$, production $y(t) = x_1(t)/x_3(t)$ and the final value $x_3^* = x_3(t^0 + t^*)$.

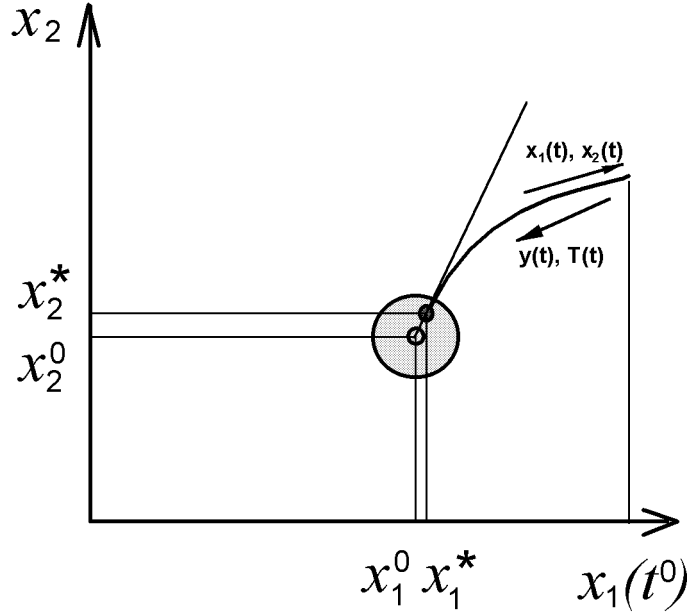

Fig.5 The ϵ -neighborhood of the stationary point and an integration pattern. The arrow pointing to the right symbolizes the integration in reverse time, and the arrow pointing to the left the integration in direct time.

At the second stage we apply a suboptimal feedback which leads trajectories of system (2.12) from x_1^*, x_2^*, x_3^* to x_1^0, x_2^0, x_3^0 (see [Tarasyev, Watanabe, 1999]):

$$r^* = \dot{T} = \frac{a_2 x_1}{x_3 (d + k(\omega)(x_1 - x_1^0) + \omega(x_1 - x_1^0)^2)} = \frac{a_2 y}{(d + k(\omega)((y/T) - x_1^0) + \omega((y/T) - x_1^0)^2)}. \quad (3.2)$$

Here

$$d = gx_2^0 - (p^0 - x_2^0)x_1^0, \quad k = k(\omega) = k_1\omega + k_2, \quad k_1 = x_1^0 + g, \quad k_2 = -(p^0 - x_2^0). \quad (3.3)$$

The coefficient ω in (3.2) is the slope of the eigenvector corresponding to the negative eigenvalue of the Jacobi matrix (3.1). The quasioptimal feedback corresponds to the linear regime for the second coordinate $x_2(\cdot)$,

$$x_2 = x_2^0 + \omega(x_1 - x_1^0), \quad \omega \geq 0, \quad (3.4)$$

and can be considered as an approximation to the optimal regime. A key property of the quasioptimal feedback is that it ensures the convergence of the trajectory to the equilibrium point.

Table 2: Algorithm

<p>1) Choosing initial deviations in the ϵ-neighborhood of the stationary point (x_1^0, x_2^0) :</p> $x_1 := x_1^*, \quad x_2 := x_2^*$
<p>2) The integration of the first two equations of the reduced system;</p> $\dot{x}_1 = f_1 + f_2 x_1^{(1-\gamma)} - \frac{a_2(x_1+g)x_1}{((x_1+g)x_2-p^0x_1)},$ $\dot{x}_2 = \rho x_2 + \gamma f_2 x_2 \frac{1}{x_1^\gamma} - 1 - \frac{a_2 g x_2}{((x_1+g)x_2-p^0x_1)}$ <p>in reverse time until $x_1(t^0) = y(t^0)/T(t^0)$.</p>
<p>Intermediate results: the optimal trajectories $x_1(t)$ and $x_2(t)$ which enter the ϵ-neighborhood of the stationary point (x_1^0, x_2^0).</p>
<p>3) The integration of the third equation of the reduced system</p> $\dot{x}_3 = -\frac{a_2 x_1 x_3}{((x_1+g)x_2-p^0x_1)}$ <p>in direct time.</p>
<p>Output:</p> <p>$T(t) = 1/x_3(t)$ - optimal technology, $y(t) = x_1(t)/x_3(t)$ - optimal production.</p>

4 Clusters of Theoretically Optimal Scenarios and Empirical Data Series

The variations in model's parameters give rise to clusters of theoretically optimal trajectories. The association of such synthetic optimal clusters with the empirical time series may give a useful information on the aggregated quality of economic management and possible alternative scenarios of growth. The synthetic clusters may also serve for the estimation of the sensitivity of optimal trajectories with respect to the variations in different parameters or their combinations. This sensitivity analysis could be of special interest in situations when a growth process under consideration is qualified by experts as optimal or close to optimal. In these situations parameters, with respect to which the optimal evolution is strongly sensitive (the associated clusters are "broad"), can be identified. Controlling such critical parameters could, consequently, be viewed as an essential element in global economic management.

Fig.6, 7 show, respectively, the clusters of theoretically optimal trajectories which arise as the elasticity coefficients α and β_1 run through the admissible interval $(0, 1)$ ($\alpha = 0.85, \dots, 0.95$, $\beta_1 = 0.1, \dots, 0.9$). Here the following reference values for the parameters, initial time t^0 , initial production $y(t^0)$ and initial technology $T(t^0)$ are assumed:

Parameters:

$$\gamma = 0.1$$

$$\alpha = 0.91$$

$$\rho = 0.033$$

$$\beta_1 = 0.5$$

$$\beta_2 = 0.4$$

$$f_1 = 0.035$$

$$f_2 = 0.015$$

$$g = 0.6$$

Initial conditions:

$$y(t^0) = 157360.0$$

$$T(t^0) = 5620.0$$

$$t^0 = 1970.0$$

The choice of β_1 and β_2 is based on C.Watanabe's empirical analysis presented in the abstract [Watanabe, 1997 b]. In Fig.6, 7 the clusters of theoretically optimal trajectories are associated with the empirical time series in production, technology and technology productivity in Japan in 1970-1992 (the data series are shown in squares). We see that the optimal trajectories agree well with the empirical time series and are quite robust with respect the elasticity parameters. This gives an example of a partial sensitivity analysis via the designed software. As the software is complemented by a user-friendly interface, it will be used for carrying out a complete

numerical sensitivity analysis, in which the variations of all system's parameters around estimated reference values will be taken into account.

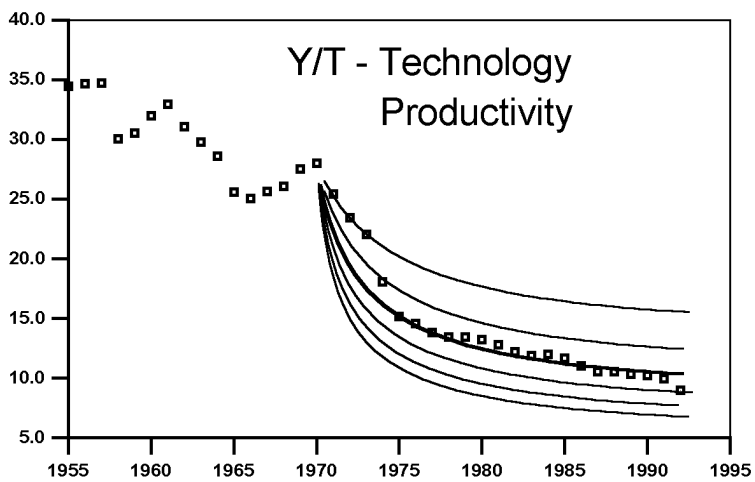
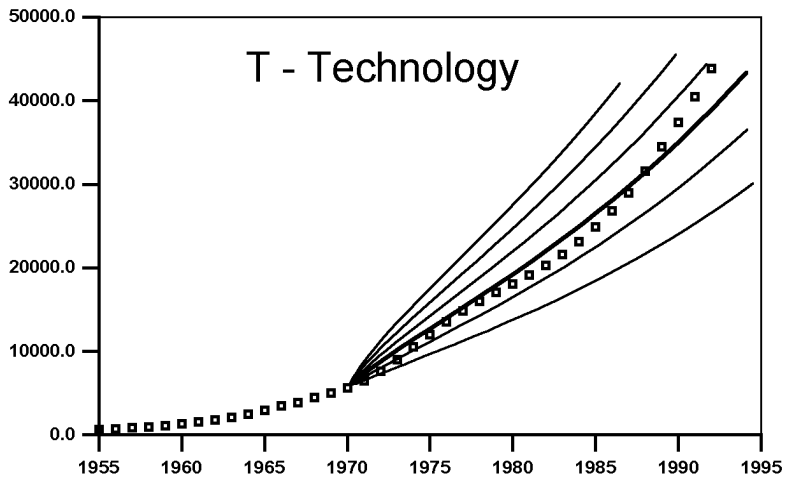
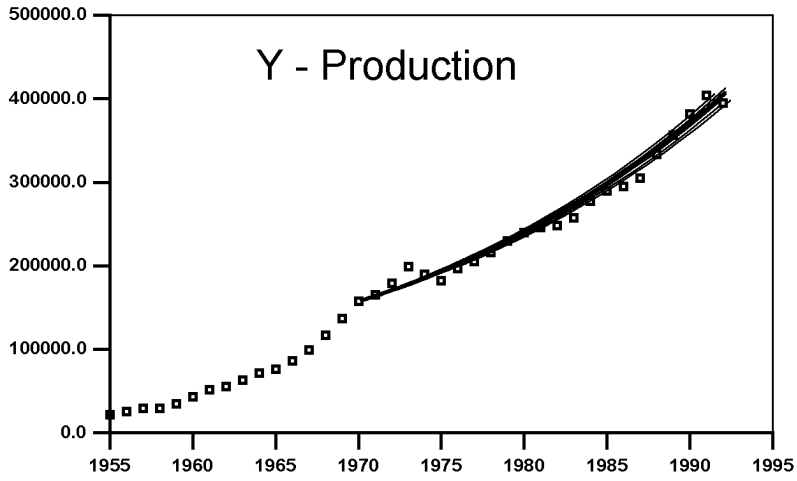

Fig.6 Optimal trajectories: $\alpha = 0.85, \dots, 0.95$

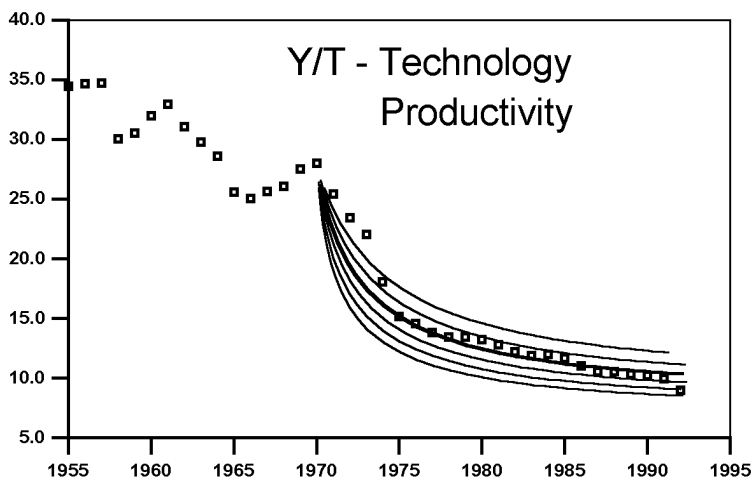
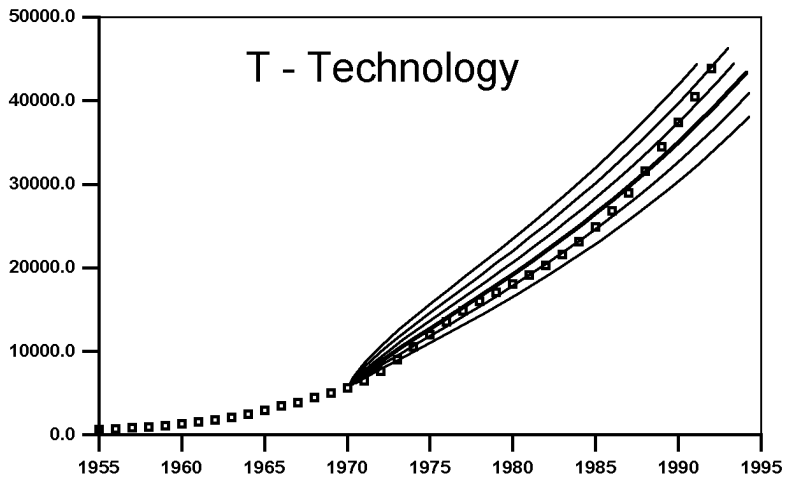
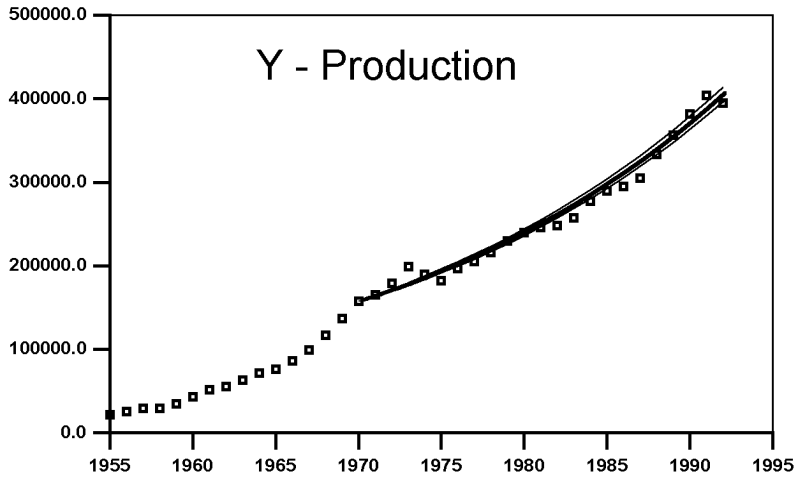

Fig.7 Optimal trajectories: $\beta_1 = 0.1, \dots, 0.9$

Conclusion

In this paper a nonlinear model of optimal allocation of R&D in a techno-metabolic system ([Tarasyev, Watanabe, 1999]) is matched with the aggregated data on the Japanese manufacturing industry. The model describes the dynamics of production and technology as a response to the R&D investment policy. The optimal dynamics reflects basic qualitative trends in econometric time series for technology, production and technology productivity. The simulations agree well with a conjecture that the actual economic management in Japan was close to theoretically optimal in period 1970-1992. The main technical difficulty in the work was to ensure the convergence of extremal trajectories to the unstable equilibrium. This paper describes a method for finding suboptimal trajectories (analytical estimate of the accuracy is given in Appendix). The method is realized in a software. We plan to develop a user-friendly interface for this software and make it available via Internet. The software will be applied for the numerical analysis of specific economy branches and simulation of various decision-making rules.

The work has been performed within the framework of the joint research program of IIASA and the Tokyo Institute of Technology on *Comparative Analysis of the Endogenous Techno-economic Process: Technology Spillovers in Japan, the USA, Europe and APEC Countries*.

5 Appendix: Accuracy Estimation

Here we give an analytic estimate of accuracy of the suboptimal feedback (3.2) in the ϵ -neighborhood of the stationary point.

Let us substitute the optimal control law (2.8) in the functional (2.6). According to (2.10),(2.11) we have

$$U = \int_0^\infty e^{-\rho t} ((1 + a_2) \ln x_1 - p_0 \rho \ln x_3 - a_2 \ln((x_1 + g)x_2 - p^0 x_1)) dt. \quad (5.1)$$

Without loss of generality we assume that initial instant is 0.

Consider the following problem.

Problem 1. Let for all $t > t^* > 0$ functions $x_1(t)$, $x_2(t)$ have the form

$$x_1(t) = x_1^0 + \delta x_1(t), \quad x_2(t) = x_2^0 + \delta x_2(t). \quad (5.2)$$

Here x_1^0 , x_2^0 are the components of the equilibrium point of the reduced system (2.12), and $\delta x_1(t)$, $\delta x_2(t)$ are sufficiently small such that

$$\lim_{t \rightarrow \infty} x_1(t) = x_1^0, \quad \lim_{t \rightarrow \infty} x_2(t) = x_2^0.$$

(these conditions hold if $(x_1(t), x_2(t))$ is driven either by an optimal control, or by the suboptimal feedback (3.2)).

Furthermore, let $x_3(t^*)$ be given and $x_3(t)$ is governed by the third equation in system (2.12).

It is required to estimate the value of the functional

$$U_{t^*} = \int_{t^*}^\infty e^{-\rho t} [(1 + a_2) \ln x_1 - a_2 \ln((x_1 + g)x_2 - p^0 x_1)] dt - p_0 \rho \int_{t^*}^\infty e^{-\rho t} \ln x_3 dt \quad (5.3)$$

Solution of the Problem 1. Suppose that for all $t > t^*$

$$|\delta x_1| < \Delta_1, \quad |\delta x_2| < \Delta_2 \quad (5.4)$$

where Δ_1 , Δ_2 are sufficiently small constants. Taking into account the relation

$$\lim_{t \rightarrow \infty} \frac{\ln x_3}{e^{\rho t}} = \lim_{t \rightarrow \infty} \frac{(\ln x_3)'}{(e^{\rho t})'} = \lim_{t \rightarrow \infty} \frac{-a_2 x_1 e^{-\rho t}}{\rho((x_1 + g)x_2 - p^0 x_1)} = 0,$$

we rewrite the last term in (5.3) as

$$\begin{aligned} -p^0 \rho \int_{t_0}^\infty e^{-\rho t} \ln x_3 dt &= p^0 e^{-\rho t} \ln x_3 |_{t_0}^\infty - p^0 \int_{t_0}^\infty e^{-\rho t} \frac{\dot{x}_3}{x_3} dt = \\ &= -p^0 e^{-\rho t_0} \ln x_3(t_0) + p^0 \int_{t_0}^\infty \frac{a_2 x_1 e^{-\rho t}}{(x_1 + g)x_2 - p^0 x_1} dt. \end{aligned}$$

Substitute this in (5.3):

$$U_{t^*} = \frac{e^{-\rho t^*}}{\rho} \left((1 + a_2) \ln x_1^0 - a_2 \ln((x_1^0 + g)x_2^0 - p^0 x_1^0) + \frac{p^0 a_2 x_1^0}{(x_1^0 + g)x_2^0 - p^0 x_1^0} \right) -$$

$$-e^{-\rho t^0} p_0 \ln x_3(t^0) + \Delta. \quad (5.5)$$

Here

$$\begin{aligned} \Delta = \int_{t^*}^{\infty} & \left[\frac{p^0 a_2 x_2^0 (g \delta x_1 - \delta x_2 (x_1^0 + g))}{((x_1^0 + g)x_2^0 - p^0 x_1^0)^2} + (1 + a_2) \frac{\delta x_1}{x_1^0} - a_2 \frac{\delta x_1 (x_2^0 - p^0) + \delta x_2 (x_1^0 + g)}{(x_1^0 + g)x_2^0 - p^0 x_1^0} \right] \times \\ & \times e^{-\rho t} dt + o(\epsilon). \end{aligned} \quad (5.6)$$

Using inequalities (5.4), we obtain

$$\begin{aligned} |\Delta| < \frac{e^{-\rho t^*}}{\rho} & \left[\frac{p^0 a_2 x_2^0 (g \Delta_1 + \Delta_2 (x_1^0 + g))}{((x_1^0 + g)x_2^0 - p^0 x_1^0)^2} + (1 + a_2) \frac{\Delta_1}{x_1^0} + a_2 \frac{\Delta_1 (p^0 - x_2^0) + \Delta_2 (x_1^0 + g)}{(x_1^0 + g)x_2^0 - p^0 x_1^0} \right] + \\ & + o(\epsilon). \end{aligned} \quad (5.7)$$

According to (5.7) the absolute value of Δ is infinitely small as $\epsilon \rightarrow 0$. Thus, we come to the following result. Under the suboptimal control (3.2) the functional U_{t^*} converges to a constant determined by the first two terms in (5.5) as $\epsilon \rightarrow 0$.

References

- Arrow, K.J., Production and Capital. Collected Papers. Vol.5, The Belknap Press of Harvard University Press, Cambridge, Massachusetts, London, 1985.
- Arrow, K.J., Kurz, M., Public Investment, the Rate of Return and Optimal Fiscal Policy, Baltimore: Johns Hopkins University Press, 1970.
- Griliches, Z., R&D, Patents, and Productivity, The University of Chicago Press, Chicago, London, 1984.
- Grossman, G.M., Helpman, E., Innovation and Growth in the Global Economy, M.I.T. Press, Cambridge, Mass., 1991.
- Hutschenreiter, G., Kaniovski, Yu., Kryazhimskii, A., Endogenous Growth, Absorptive Capacities and International R&D Spillovers, IIASA WP-95-92, 1995.
- Intriligator, M., Mathematical Optimization and Economic Theory, Prentice-Hall, N.Y., 1971.
- Pontryagin, L.S., Boltyanskii, V.G., Gamkrelidze, R.V., Mishchenko, E.F., The Mathematical Theory of Optimal Processes, Interscience, New York, 1962.
- Tarashev, A.M., Watanabe, C., Optimal Control of R&D Investment in a Techno-Metabolic System, IIASA, 1999
- Watanabe, C., Trends in the Substitution of Production Factors to Technology – Empirical Analysis of the Inducing Impact of the Energy Crisis on Japanese Industrial Technology, Research Policy, 1992, Vol. 21, P. 481-505.
- Watanabe, C., The Interaction between Technology and Economy: National Strategies for Constrained Economic Environments. The Case of Japan 1955-1992, IIASA, 1995.
- Watanabe, C., Factors Governing a Firms' R&D Investment - a Comparison between Individual and Aggregate Data, IIASA, TIT, OECD Technical Meeting, Paris, 1997.
- Watanabe, C., A Technometric Approach to the Dynamic Mechanism of Technological Innovation, Abstract of Annual Conference of the Japan Society for Science Policy and Research Management (Tsukuba, 1997), 73-78, 1997.
- Watanabe, C., Systems Factors Governing Firms' R&D Investment – A Systems Perspective of Inter-Sectoral Technology Spillover, IIASA, TIT, OECD Technical Meeting, Laxenburg, 1998.