

INDUSTRIAL TECHNOLOGY:
PROBLEM-ORIENTED APPROACH

German D. Surguchov

November 1976

Research Memoranda are interim reports on research being conducted by the International Institute for Applied Systems Analysis, and as such receive only limited scientific review. Views or opinions contained herein do not necessarily represent those of the Institute or of the National Member Organizations supporting the Institute.

PREFACE

The development of modern industrial technology and improved efficiency can be achieved by means of operational control and management, research and development and design. These three areas and the corresponding sub-problems can be identified, investigated and solved on the basis of problem-oriented mathematical models.

Having devised some general approaches to the development of such models, a particular example is considered: steelmaking in basic oxygen furnaces (BOF), which was developed in Austria in the early 1950s and is the most widely used in the world.

The mathematical models presented in this paper have been developed partly at the Moscow Institute for Steel and Alloys (USSR) and partly at IIASA.

They are not described in great detail, but their general structure, and in particular the technological problems that have been solved with their help, are described. It is intended to extend the area of model application in future work.

ABSTRACT

The three problems - operational control and management, research and development and design - form the basis for increasing the efficiency of modern industrial technology and developing a new one. The general approach to the development of the problem-oriented models has several particular features which depend on the problems to be solved: knowledge and data about the systems to be modeled, demand for model accuracy, type of model solution (off-line or on-line), computer type, etc.

Different kinds of mathematical models which are implemented for operational control and management, research and development and design of a modern industrial technology - steelmaking in basic oxygen furnaces (BOF) - have been considered.

The problems which were formulated, the approaches to the development of the mathematical models and the processes which occur in BOF technology, are typical for other different kinds of industrial technology, e.g. chemicals, cement industry, atomic reactors, glass industry.

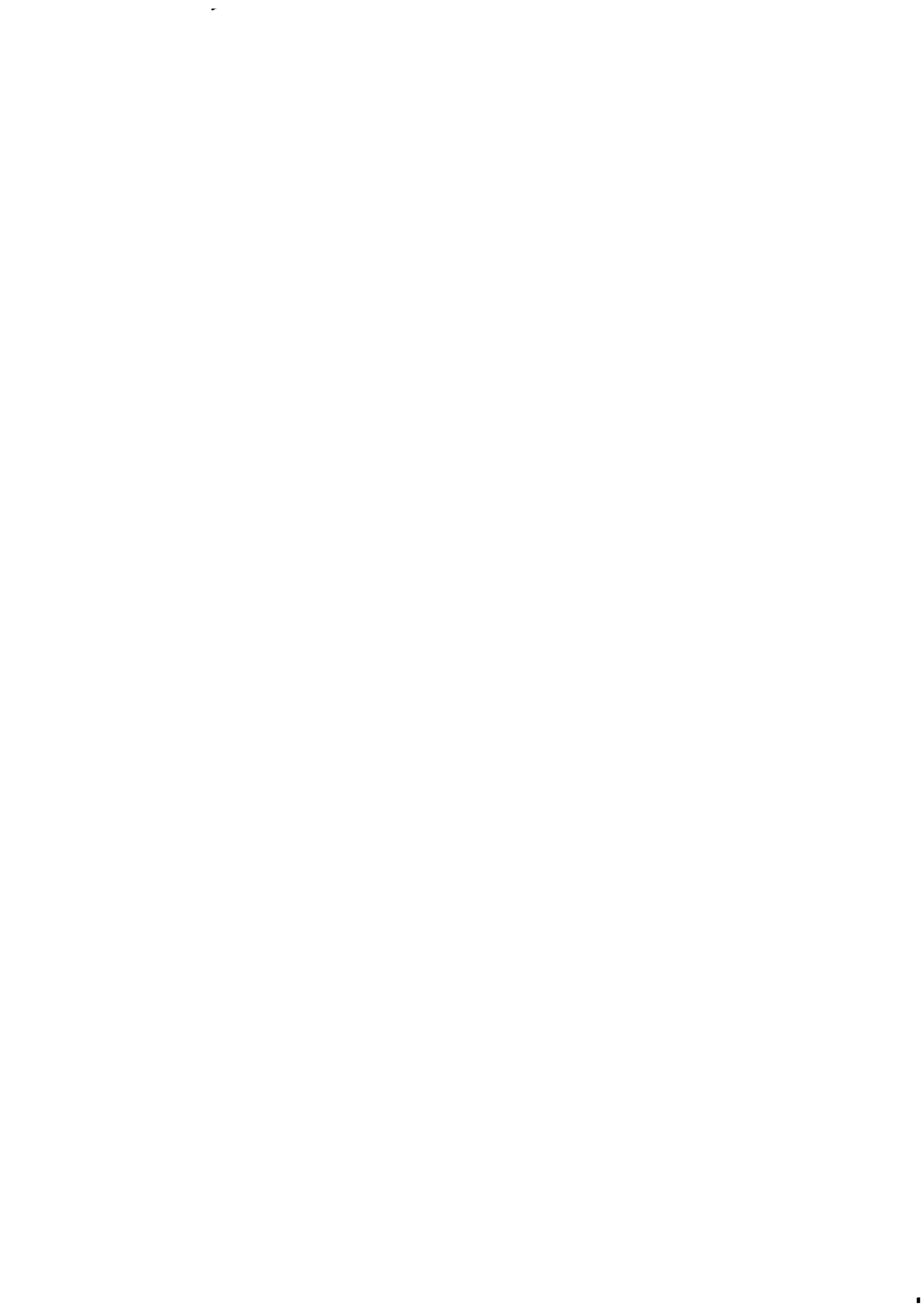

INDUSTRIAL TECHNOLOGY:
PROBLEM-ORIENTED APPROACH

INTRODUCTION

Technology has been defined by Webster as "technical methods for a practical purpose" or "the totality of the measures employed to provide objects necessary for human sustenance and comfort;" Gross et al defines technology as the systematic application of scientific or other organized knowledge to practical tasks [1]. It must be kept in mind that technology tries to attain optimal performance by maximizing efficiency, by conserving resources, raw materials, and energy, and by minimizing costs, pollution, etc.

To achieve these goals - using technology in a more effective way and developing and implementing new and more efficient technologies - it is necessary to identify a number of problem areas: technological forecasting, evaluation of technological impact, innovation and implementation, etc. There are some linkages among these as is shown in Figure 1. These are mostly encountered with large-scale systems; the technology considered in this paper belongs to this group. Let us call these "external" problems.

Moreover, with respect to technology, and especially to industrial technology, three "internal" problems affecting the efficient use of technology can be defined. First, the existing technology should be controlled and managed operationally in order to achieve and maintain optimal indices. To do this, we should consider different tasks, some of which are connected with the technology itself or with the technological units, e.g. process or production control, and optimization. On the other hand, the technology may be a part of a large-scale system dealing with operational management, including scheduling and planning.

Each technology should be considered a *developing system*. The development needed to improve the techno-economical indices of the technology is realized by research. Research and development of internal problems may be defined in the applied sense in connection with the technology considered. They are part of the general "external" research and development problem which has many social, economic, organizational and managerial consequences.

The research and development of modern technology can provide a basis for the design of new technologies. Design, in the broad sense, includes such activities as shaping a piece of

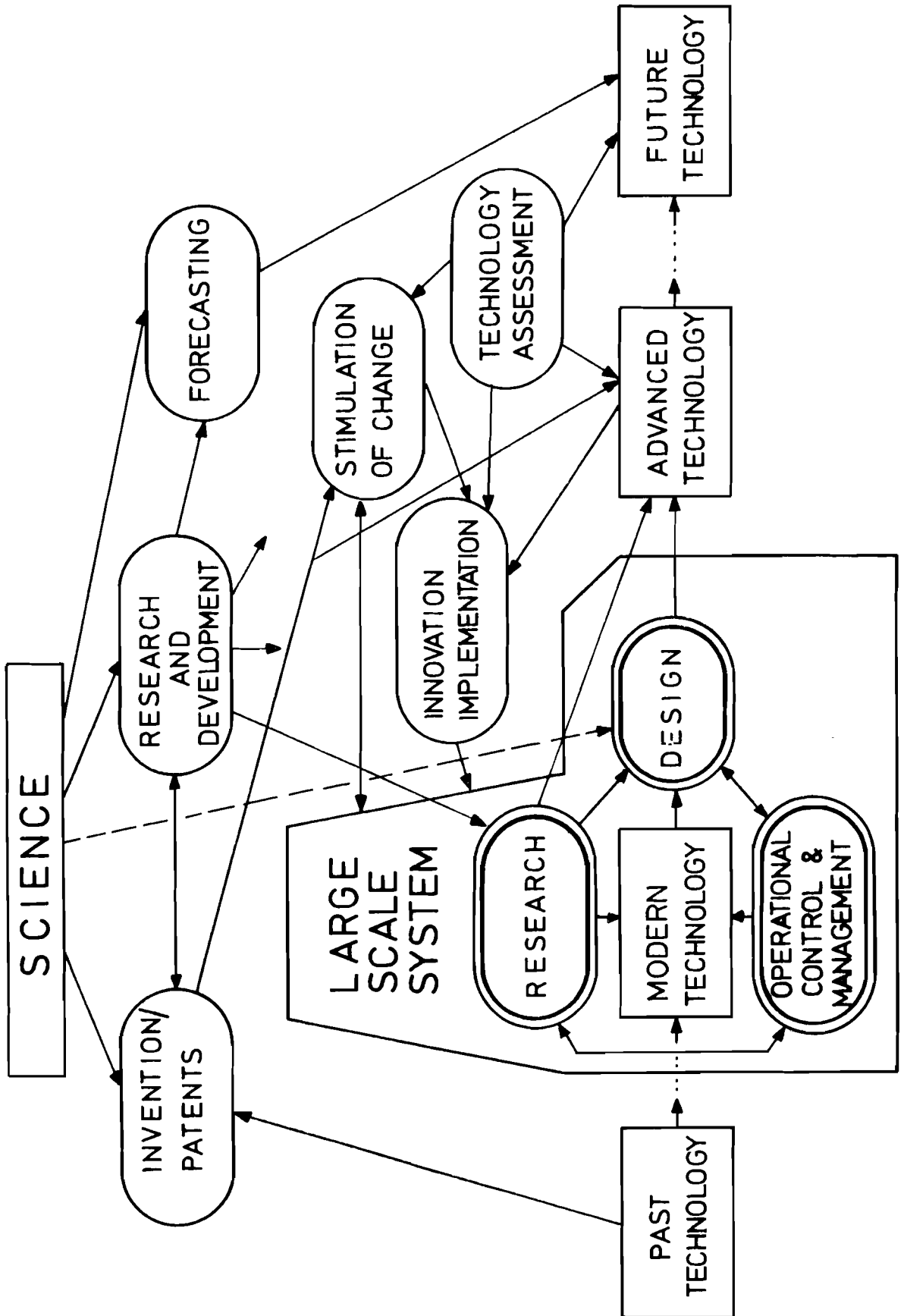

Figure 1.

equipment and identifying alternative energy sources to power new machines [1]. For our purposes we will define design in the applied sense - designing advanced technology based on specialized modern technology.

There is a connection among the three problem areas mentioned above. Research can be carried out for control or design purposes; the new technology may be designed so as to satisfy the controllable demand, and so on.

The method for studying the problem will vary depending on the level of the system to which the technology belongs. Each technological problem should be considered in terms of its linkages with other levels within the system. Operational control and management problems can be considered not only for concrete technology, but also for plants, enterprises or sectors. Computer-based management systems are developed as integrated systems which embrace different managerial levels.

Improving the indices of a technology or creating a new technology will influence the other levels within the system; this will ultimately be felt at the highest levels - the national and international levels.

Thus, the problems that have been identified should be discussed separately for each of the levels within the system (see Figure 2). However, problems that arise at the highest level of a large-scale system greatly influence the type of technology needed. For example, the energy crisis created problems on the national and international levels that have affected the current demand for modern resource-conserving technologies, e.g. recycling technology, solar-energy and water power.

There are other factors that must be considered such as the type of technology and the level at which it will be used (e.g. plant, region) and the actual type of industrial technology or process. For example, the operational control and management involved in automobile manufacture differs from that needed for oil refining.

To illustrate the approach to the development of problem-oriented models, we have chosen the steelmaking technology for several reasons. First, steelmaking is an important technology in the steel industry, which is a basic industry. Second, the processes in the steelmaking technology are typical of other kinds of continuous or semi-continuous industrial technologies, such as chemical technology, refining and food technology. Third, steelmaking makes broad use of mathematical models and computers. This report concentrates on the latter aspect of steelmaking. The main purpose of the paper is to explain the use of the systems approach for the study of technological problems. The systems approach is essential in developing the problem-oriented models, and in orienting the simulation technique for the problems being considered.

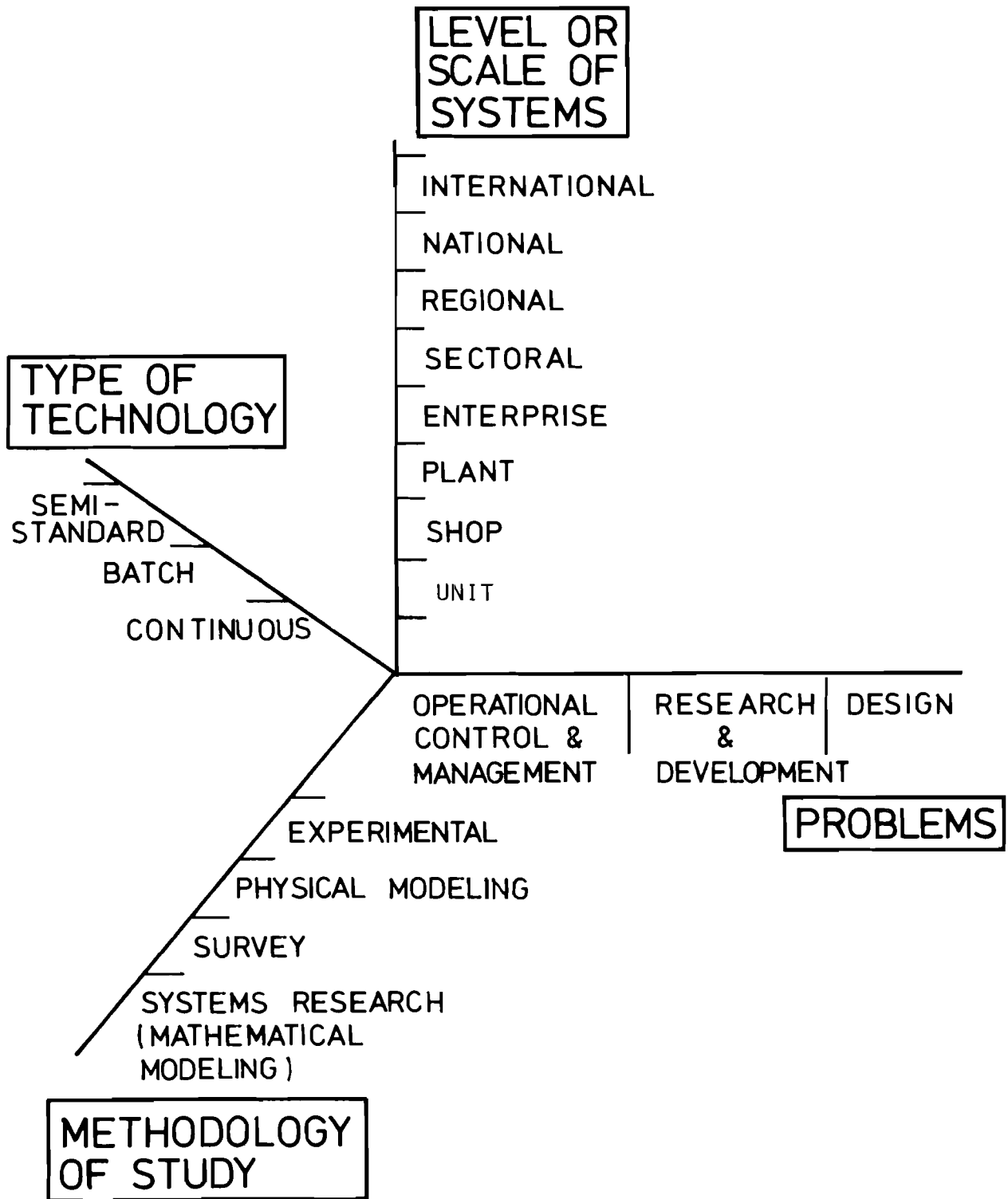

Figure 2.

DEVELOPMENT OF PROBLEM-ORIENTED MODELS

Systems research includes developing and applying mathematical modeling techniques. Systems analysis is needed to apply such techniques particularly simulation techniques. The procedure for developing mathematical models is as follows:

- Define the general problem and formulate the specific objectives;
- Study the system being modeled;
- Develop the model using mathematical quantitative descriptions;
- Choose the computer algorithms and program;
- Verify the model on the basis of real (available) data; and
- Utilize the model.

There is feedback among the above-mentioned steps (see Figure 3). For example, study of the real system may show that the model as originally developed cannot solve the problem; thus it would be necessary to redefine more accurately the goals of the modeling exercise. Also, after verifying the model on the basis of real data, it may be necessary to adjust the model e.g. by changing the structure or making the coefficients of the model more precise. The utilization of the model should improve the existing system or it should contribute to the development of a new one.

Each of these procedural steps is interdependent, and the model's characteristics will depend on the type of problem to be solved. Selected features of the above-mentioned procedure are shown in Table 1.

Various factors must be considered when studying the system for a modeling view point. For identifying operational (management and control) and research problems, data exists on the technological system that can be used for model development. As for the development of models to help in the design of new technologies, there is often some delay or the model description is not precise owing to a lack of real data. In the latter case, previous experience could be used or an analog technological system could be studied. Nevertheless, there may still be insufficient information for developing the verifying "design" models since data are required for applying the statistical method to the development of design models.

Operational models should be solved "on-line" in accordance with the technology cycle, and should have a high accuracy level; the latter determines the properties of models such as limited size, and universal computer implementation.

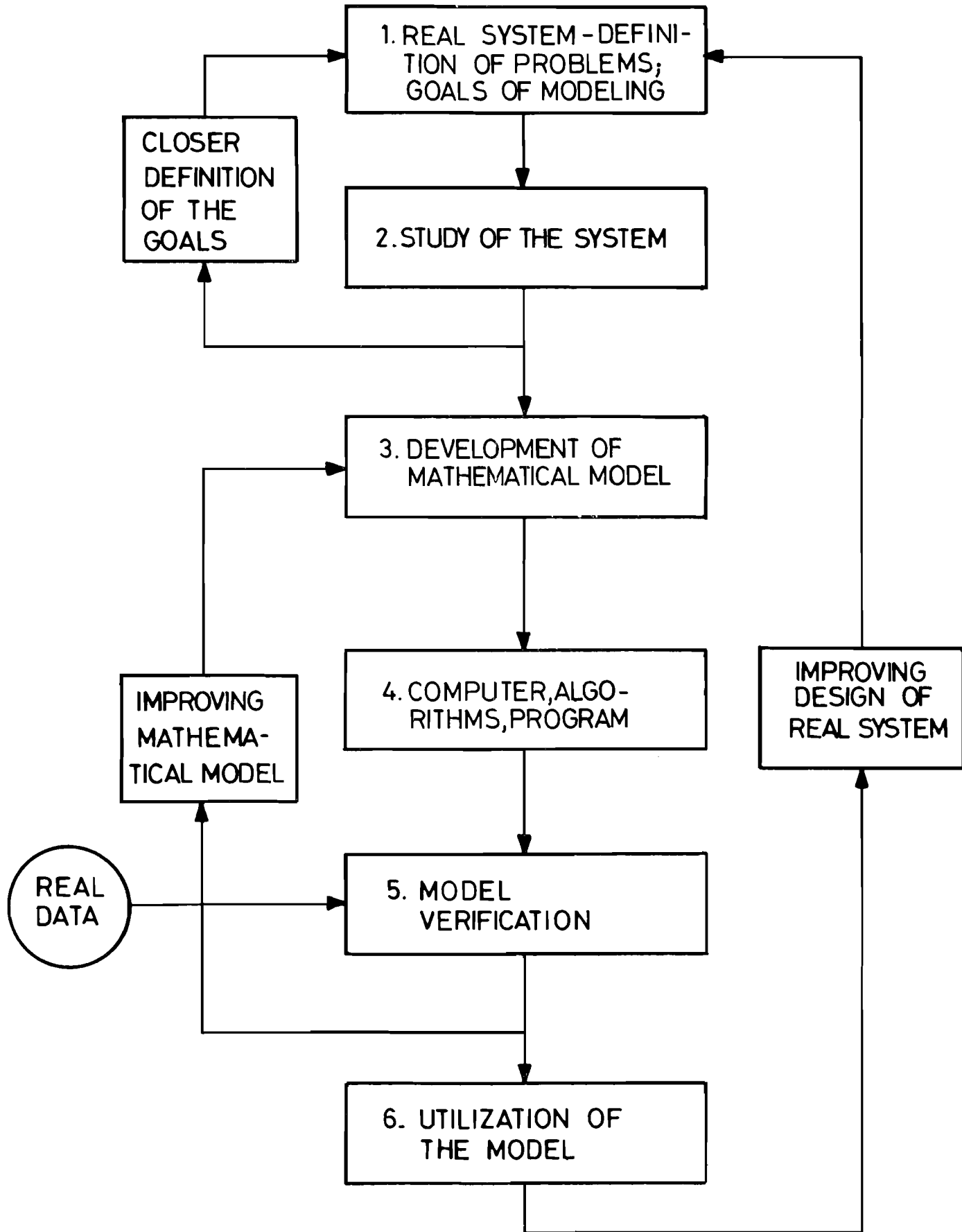

Figure 3.

Steps	Problems	Operational control and Management	Research	Design
I		II	III	IV
Problems identification		Improvement of indices in technology in operation by means of operational control and management	Improvement of indices of up-to-date technology by means of research and development	Design of advanced (new) technology
Special features of the study of the system being modelled		Knowledge and data available. Implementation of special methods of study: experimental, statistical, etc.	Knowledge and data available. Implementation of special methods of study: experimental, statistical, etc.	Not enough knowledge and data
Developing the mathematical model		<ul style="list-style-type: none"> - Analytical - Experimental - Combined 	<ul style="list-style-type: none"> - Analytical - Experimental - Combined 	<ul style="list-style-type: none"> - Analytical - Combined
Model's size/complexity		Limited	Any complexity	Any complexity
Computer		Universal	Analog/Universal	Analog/Universal
Solution		Off-line/On-line	Off-line	Off-line
Model verification		Necessary comparative data available	Possible comparative data available	Difficult - no comparative data
Possible or necessary accuracy		High	Middle/high	Low

Table 1.

Research and design models are solved "off-line," thus it is possible to have different degrees of complexity in the model and also to use universal or analog computers. Clearly, one should aim at achieving high accuracy in the model, but in some cases only medium or even low accuracy levels are achieved.

Some approaches to developing the mathematical models are shown in Figure 4. An "analytical" model (often called a physical model - see A in Figure 4) can be developed on the bases of modern science, theoretical knowledge, and experience in the field being considered. Similarly, heuristic models can be developed based on knowledge, past experience and/or modern science. On the other hand, an "experimental" model (often called a statistical model - see B in Figure 4) can be developed using the "black-box" principle and taking into consideration the behaviour of the input and output parameters.

Another way to develop the mathematical model is to implement the study of the pilot technology (see C in Figure 4). The study can be conducted in special pilot units or in installations, with a view to identifying separate processes in the technology, to designing the new technology, etc. The results of these investigations can be used for developing the mathematical model on an experimental basis.

The advantages and disadvantages of analytical and experimental approaches are well known. Applying a combination of both types of models is even more advantageous (see AB, AC, ABC, in Figure 4). These combined models use the classical laws and experimental data (e.g. coefficients, and equations), and are most widely used in the technological field.

There are, of course, many other special features of the models used in problem-solving; some additional features will be discussed later in this report.

INDUSTRIAL TECHNOLOGY: STEELMAKING IN BASIC OXYGEN FURNACES (BOF)

Basic to the steel industry is the production of crude iron in blast furnaces, and the production of strips, sheets and bars in rolling mills. The processes that take place in the steel industry and in steelmaking in particular are technologically similar to those utilized in other industries such as chemicals, oil-refining, and the food industry. Thus the results of this study may have application to these industries.

The characteristics of modern steelmaking should be viewed from a historical perspective. For example, the duration of the production cycle in the steel industry has decreased tenfold over the last decade (Figure 5). The steelmaking process is continuously developing.

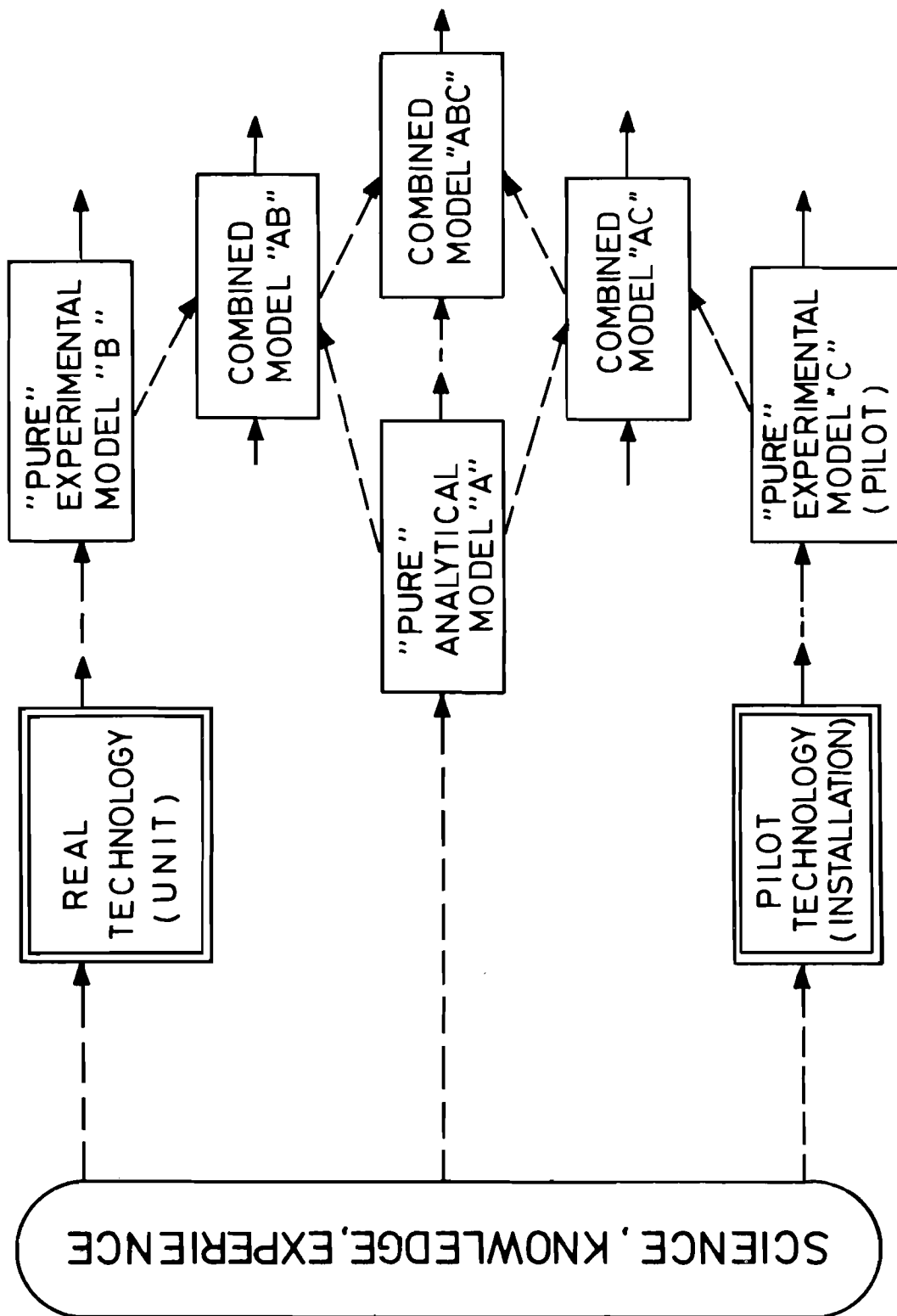

Figure 4.

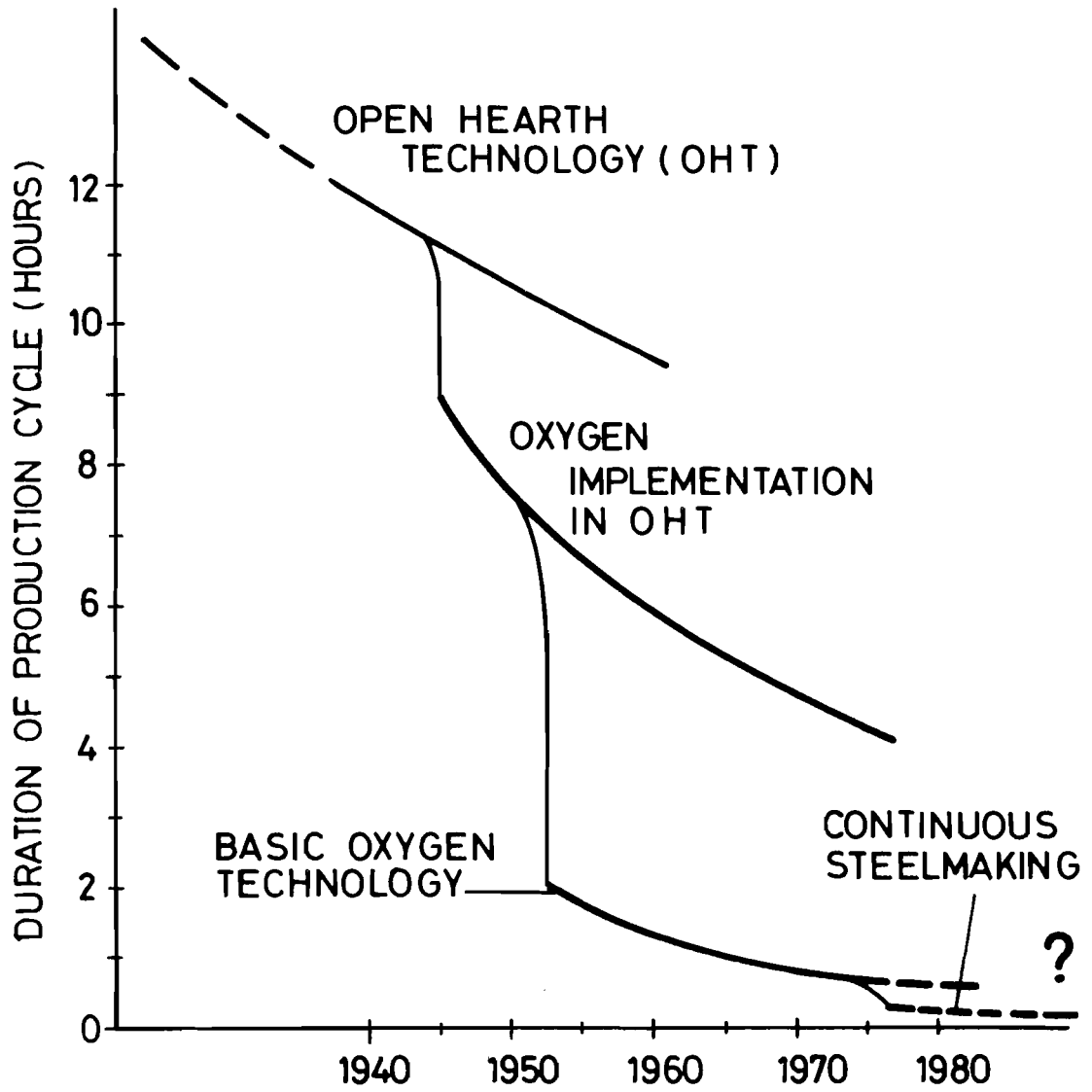

Figure 5.

Data for world steel production, utilizing different technologies, is shown in Table 2 [2]. Steel is also produced using the bottom-blown converter. However, steelmaking utilizing the BOF technology is the most widely used in the world.

Table 2. World steel Production
(in millions of tons)

Year	Open-hearth	Basic Oxygen Furnaces (BOF)	Electric Arc	Total Production
1960	68.5	3.8	10.3	347
1965	59.0	16.4	12.0	454
1970	38.8	41.5	13.8	589
1975	30.7	52.7	14.4	735

SOURCE: [2]

The BOF technology, called L-D-Verfahren (Linz-Donawitz-Process) was developed in Austria in 1952 [3]. The technological process is shown in Figure 6. Molten pig iron and scrap, as well as a number of additives, e.g. ore and lime, are put into the converter. The oxygen is then blown through the converter so as to yield the permissible value for temperature and composition (e.g. C, Si, Mn). The major operational objectives of the BOF technology are as follows (see Figure 7): to operate by means of the input parameter (e.g. oxygen throughput, ore, lime, position of lance) to achieve the permissible value of the given output parameters (e.g. steel composition, temperature, slag composition) by means of the minimal dispersion (e.g. time, materials, costs). The production cycle is about one hour, tap-to-tap and blowing time is about 25 minutes. The main output parameters should be given a value simultaneously. If this can be done additional resources (e.g. oxygen and time additives) are needed.

Some other indices of the BOF technology are: converter capacity (up to 400t), productivity (up to 500 t/h), blow time (15 - 50 minutes), oxygen rate (50 - 60 m³/t), part of scrap in charge (20 to 30 percent) and metallic yield (91 to 92 percent).

The processes being carried out using this technology can be divided as follows (Figure 8): mass transfer, heat transfer, slag formation, heating and solution of solid additives, chemical kinetics and mass balance-heat balance. The study and description of steel processes is based on the laws of chemical thermodynamics, kinetics, hydrodynamics, mass and heat transfer, etc. The main process in the technology is carbon oxidation which plays a part in the CO gas formation in the fluid metal, and greatly influences such processes as mass and heat transfer and slag formation.

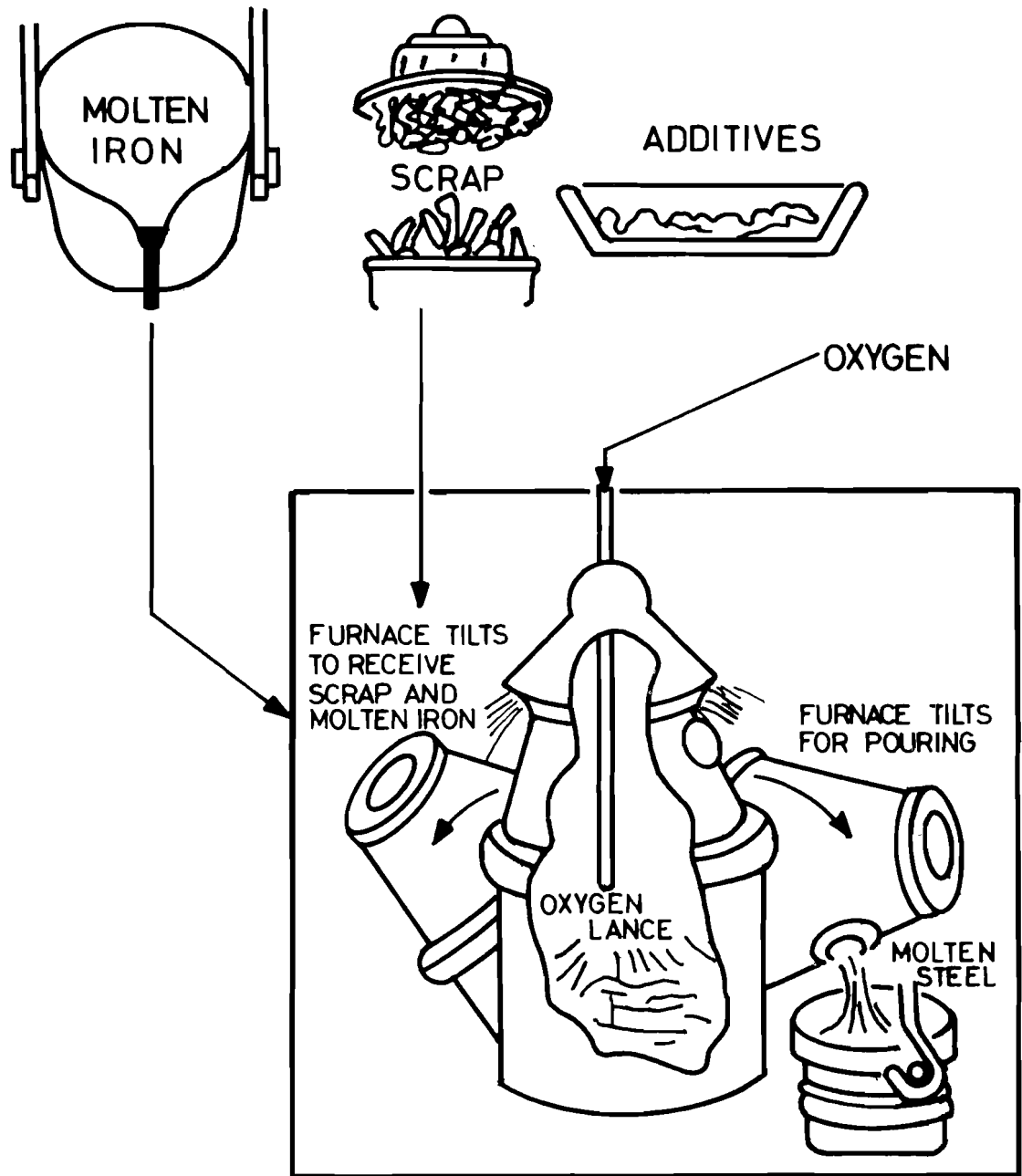

Figure 6.

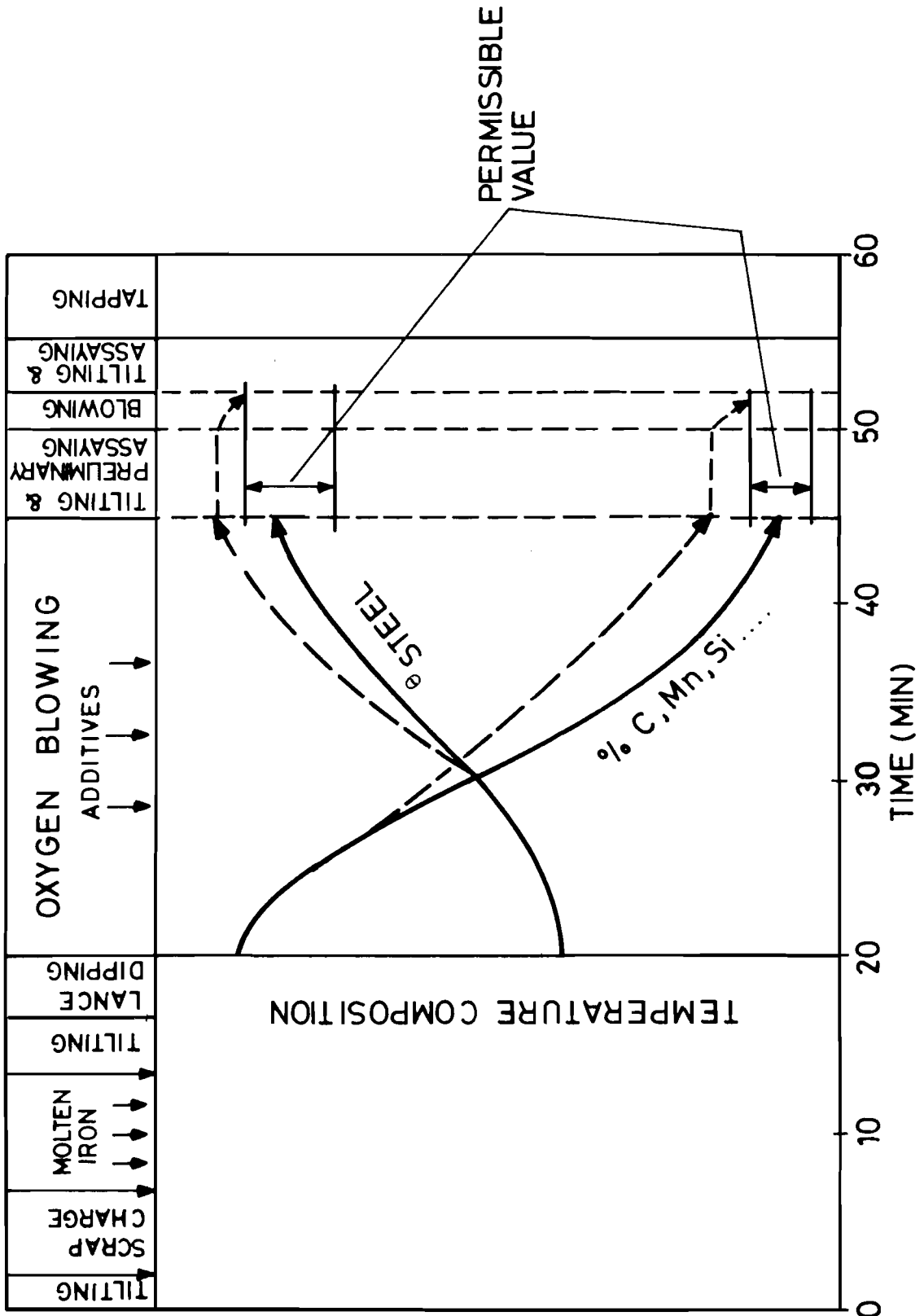

Figure 7.

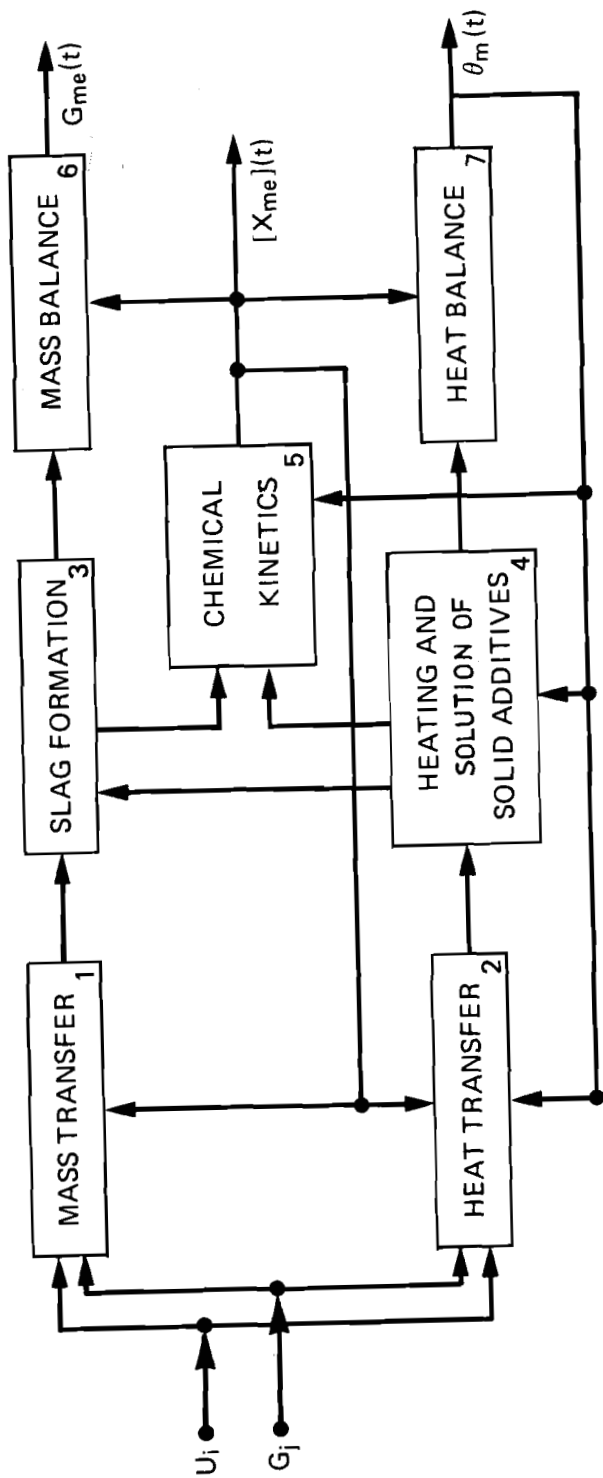

Figure 8.

The problems encountered have a number of special features. The need for operating computer-based control for the BOF is determined by the high speed and productivity of the technology. Compared to other steel processes (e.g. open hearth furnaces) the BOF is a high speed technology. The operator who manages the process does not have sufficient time to calculate all the alternatives and to make the best decision on the basis of available information.

The analysis of the results of six steel plants using the BOF technology shows us that only 30 to 50 percent of the heats achieved the desired final conditions for temperature and composition, particularly carbon concentration. The remaining 70 to 50 percent had to be reblown; this required additional resources e.g. time, raw materials and oxygen.

Applying computer-based control systems improves these indices. Predictions for the process on the basis of the so-called static control systems results in an increase in the percent of heats so that they achieve the desired final conditions, i.e. 60 to 70 percent. By using the so called dynamic systems, this percentage increased to 70 to 90 percent [4].

On the other hand, BOF is part of some large industrial complexes. The scheduling of the BOF should correspond to that of the work of other technological units, e.g. the continuous casting machines or the rolling mills. By means of the operational management of this problem (e.g. the scheduling and planning processes) it is possible to improve the efficiency of the whole system.

To solve the operational problem the mathematical model should have special properties, e.g. it has to be solved in real time in accordance with the production cycle, or in between two production cycles; it should have high accuracy, etc. These demands can be satisfied by developing the simplified models that take into consideration the general input and output parameters. In developing these models the experimental approach was mainly implemented.

There are many methods for improving the BOF steel technology on the basis of research. Table 3 shows specific fuel consumption for steel and other industrial technologies [5]. Specific fuel consumption decreased by 30 to 40 percent during the five year period 1968 - 1973. For modern technology, the specific fuel consumption is 3 to 5 times more than that of the theoretical minimum. Clearly, this theoretical minimum cannot be achieved, but it is possible to approximate this thermodynamic index on the basis of research and development. Also, the decrease in the specific fuel consumption in each kind of technology will have techno-economic consequences at other levels of the large-scale system.

Other important indexes for improving the metal yield are characterized by the cost of production, resource utilization, etc. Factors that *decrease the steel yield* will, at the same time, *increase pollution, waste products, etc.* of this technology. This index is closely linked to oxygen consumption which determines the productivity of the BOF technology, and to the scrap percentage in the charge. The latter is an important index not only at the technological or enterprise levels (see Figure 2) but also at sectoral, national and international levels.

Table 3.

	1968 Specific Fuel Consumption (Btu/ton)	Potential Specific Fuel Consumption Using Technology Existing in 1973 (Btu/ton)	Theoretical Minimum Specific Fuel Consumption Based Upon Thermodynamic Availability Analysis (Btu/ton)
Iron and Steel	26.5×10^6	17.2×10^6	6.0×10^6
Petroleum Refining	4.4×10^6	3.3×10^6	0.4×10^6
Paper	* 39.0×10^6	* 23.8×10^6	† Greater than -0.2×10^6 Smaller than $+0.1 \times 10^6$
Primary Aluminum **	190×10^6	152×10^6	25.2×10^6
Cement	7.9×10^6	4.7×10^6	0.8×10^6

*Includes 14.5×10^6 Btu/ton of paper produced from waste products consumed as fuel by paper industry.

**Does not include effect of scrap recycling.

†Negative value means that no fuel is required.

Source [5]

Different steelmaking technologies have a different percentage of processed scrap as shown in Table 4.

Table 4.

Steel Production Technology	Percentage of Scrap in Charge (%)
Electric Furnace	100
Open-hearth	50-60
BOF	20-30

The structure of a country's industry and its external trade relationship generally determine a country's scrap balance. In most countries, about 50 to 60 percent of scrap are processed in the charge. This situation, in turn influences the choice of the steelmaking technology. In Japan, for example, where manufacturing is geared toward export, the scrap problem does not exist, and the BOF technology is usually utilized. In the USSR, for example, the transition to the BOF technology is proceeding carefully in order to secure the full use of scrap and a balanced development of industry. One possible solution to the scrap problem is to combine different kinds of technologies, e.g. BOF and electric furnaces. These examples indicate types of research task with respect to BOF technology.

The design of a new technology or of technological units is very important for each technology, and in particular for BOF. The construction of converters and other technological units, the optimal construction of refractory lining and lance construction are examples of how computer-aided design could be implemented. We will concentrate here on the design of new, continuous technology based on BOF.

The current trend of different kinds of technology and particularly of steel technology, is in the direction of continuity. Together with the continuous casting machine and continuous rolling mills, the continuous steelmaking process can be a prototype of the continuous steel plant. As Figure 5 shows there is a tendency to shorten the production cycle and to organize the continuous process.

Many countries (e.g. Austria, France, Japan, the USSR, the U.K.) are working on developing a continuous steelmaking process. To develop this new technology one needs expensive calculations, experiments or pilot-units, etc. The utilization of the modeling technique, together with other methods, can decrease the costs of the design process.

AN APPROACH TO DEVELOPING MODELS OF THE BOF TECHNOLOGY

The study of a simulated system carried out after the problems have been identified included identifying the main input and output parameters, grouping the similar processes, and dividing the system into several elementary subsystems (Figure 8). Some of the subsystems are typical of other kinds of industrial technology, e.g. mass and heat transfer, kinetics, heating and solution of solid particles. Clearly, the BOF technology and other industrial technologies can be considered a complete entity. The connection between input and output parameters can be found *without* taking into consideration the elementary subprocesses that take place in the technology.

To demonstrate the three approaches presented before for developing the mathematical model - namely, analytical, experimental and combined - let us consider the *main process of the BOF technology: carbon oxidation*. These approaches can be generalized not only for other processes that take place in BOF, but also for other kinds of industrial technologies.

Using the *analytical* approach (Figure 4), the classical laws should be implemented, e.g. heat and mass transfer, mass action, matter conservation. There are many examples of this kind of BOF model [4,6,7].

A special feature of the models which are built on the analytical approach is the relative complexity of the description of each of the subsystems and the highly complex models of the whole process. Another feature is the uncertainty of a number of coefficients in the application of concrete processes.

The analytical models are useful for different kinds of research tasks: fundamental theoretical as well as applied; in some cases this approach can be implemented for the control-management problem. The analytical models, which are based on the mass and heat balance and the stoichiometric relationship are used successfully in the operation of computer systems.

The *experimental* approach is another alternative for model development. A number of models have been developed using the black-box principles [4,6,7]. The simplified example is a static model which connects the input and output parameters on the basis of regression equations (see B in Figure 4):

$$[X_c](t_{\text{final}}) = F([X_c](0), U_{O_2}, G_{\text{ore}} \dots) \quad (1)$$

where

$[x_c](t_{\text{final}})$: carbon concentration at final stage,
 $[X_c](0)$: initial conditions,
 U_{O_2} : oxygen value, and
 G_{ore} : ore value.

Equations of type (1) are widely implemented in computer systems operated in BOF enterprises. The disadvantage of the static model is that it is impossible to control or to predict the behavior of the output parameters (e.g. $[X_c](t)$) over time. To overcome this limitation, dynamic models are developed which describe the input and output behavior as a function of time [6,7,8].

The study of input and output parameter behavior has been done on a special pilot-laboratory installation because of the complexity of the BOF technology and of the difficulty and expense in experimenting directly on operating units. The

oxygen throughput and the Lance position were considered the input variable. The decarbonization rate was considered an output parameter. This investigation was made using different initial conditions (e.g. temperature and composition). The experimental results obtained from the laboratory installation were analyzed statistically, using the method of modeling functions [9]; the following equation has been developed (see C in Figure 4):

$$T_c(\theta_m, H, U_{O_2}) \frac{d[\dot{X}_c](t)}{dt} + [\dot{X}_c](t) = \zeta_{O_2}^c \cdot U_{O_2} \cdot f[X_c](t) \quad (2)$$

where

- $[\dot{X}_c](t), [X_c](t)$: function of the carbonization rate and carbon concentration in the metal;
- $T_c(\theta_m, H, U_{O_2})$: time constant, where t is the empirical function of temperature, position of Lance H, and oxygen throughput U_{O_2} ; and
- $\zeta_{O_2}^c$: grade of oxygen used for carbon oxide

Also,

$$f[X_c] = \begin{cases} 1 & \text{if } [X_c] > [X_c^{cr}] \\ f[X_c] & \text{if } [X_c] \leq [X_c^{cr}] \end{cases}$$

where

- $[X_c^{cr}]$: critical carbon concentration, characterizes the change in decarbonization.

Equation (2) is relatively simple and connects the input and output functions; it does not consider the internal processes in detail. The equation included many elementary processes such as mass transfer indirect reaction flow, and chemical reactions. This approach makes it possible to simplify the models and, at the same time, to take into account the most important in the system.

The third approach is based on a combination of the analytical and the experimental approaches (see AC in Figure 4). This approach is useful for considering the input and output behavior as well as the characteristics of the technology. The classical mass action law is used for describing the decarbonization process:

$$[\dot{X}_{me}](t) = K_{me} [X_{me}^I]^\alpha(t) \cdot (X_O)^\beta(t) \quad (3)$$

where

- K_{me} : Arrhenius constant;
 $[X'_{me}] (t)$: concentration of metal in active zone;
 $[X_o] (t)$: concentration of oxygen in the bath;
 α and β : the constants considering the order of reaction; and
 $\dot{[X_{me}]} (t)$: metal oxygen rate.

Both the reaction act and the transfer of reagents from metal volumn to the reaction place is determined in the decar-bonization process. The following equations describe the transfer of reagents:

$$T_{me} \frac{d[X'_{me}] (t)}{dt} + [X'_{me}] (t) = M_{Me} f [X_{me}] (t) \quad (4)$$

$$T_{Fe} \frac{dG_{Feo} (t)}{dt} + G_{Feo} (t) = \zeta_{O_2} \cdot S_{Feo} \cdot U_{O_2} \quad (5)$$

One additional equation considers the oxygen balance:

$$[X_o] (t) = M_{Fe} \int_0^T (G_{Feo} - \sum_{me} S_{me} [Me] (t)) dt \quad (6)$$

where

- T_{me}, T_{Fe} : time constants which characterise the transport of reactants and depend on technological conditions;
 $dG_{Feo} (t)$: the rate of formation of F_{eo} in the systems;
 $\zeta_{O_2}^{Fe}$: grade of use of the oxygen for Fe oxide;
 S_{Feo}, S_{Me} : stoichiometric coefficients;
 $\sum_{me} S_{me} [Me] (t)$: sum of the oxygen needed for oxidizing all the components; and
 M_{Me}, M_{Fe} : coefficients for model identification.

Similar approaches and equations have been used for describing other subprocesses in the BOF technology such as slag formation and solution of the hard parts of the charge. The type of elementary model for each of the selected processes will depend of the type of problem being solved.

Some common properties of the model should be emphasized. There are a number of coefficients in the development of the models, using each of the three approaches mentioned above. These coefficients can be divided into three groups. The first is the territorial constraints which are known and are tabulated. The second is the coefficients that can be calculated on the basis of experiments, literature or data. The third group of coefficients are the unknown ones which should be determined by model identification.

The task of identification can be solved within the framework of model verification (see Figure 3). Multiparameter or optimization may be used for model identification. The root mean square (RMS) error has been considered as a criterion. The identification task should be solved on a different time scale depending upon the problems being considered.

Figure 9 and 10 shows the results of identification of the models of decarbonization in pilot installation. Figure 9 shows the results of modeling, comparing the experimental data with the basic model (2). The coefficients T_C and function $f[X]$ have been considered as identification parameters. Figure 10 shows the modeling results based on equations (3), (4), (5) and (6). The identification parameters are T_C , T_{Fe} and M_O .

PROBLEMS AND SOLUTIONS

Operational Problem: to improve the techno-economic indices of the BOF technology, on the basis of maximization of the percentage of heats produced for a given value of the output parameters (e.g. temperature and carbon concentration).

This problem can be solved by means of computer-based operational control systems, based on mathematical models - in particular, the predicted static model type (1). This makes it possible to increase the percentage of heats produced with a given value of carbon concentration, as compared to that produced by manual control (Figure 11). The disadvantage of this model is its static character. While it is possible to predict the state of the processes in the final stage, the BOF technology has extremely dynamic properties. The use of a mathematical model with technological dynamic properties can increase the accuracy of the model.

The dynamic model based on equations like (2) has been used to predict the behavior and final stage of the process parameters. Three kinds of dynamic processes are considered in this model: slag building, oxygen processes and heat and material balance. As input parameters we consider the oxygen throughput and the amount of any additional resources. The output parameters are the temperature and the composition of the metals. The model is a system of 8th order differential equations. There are several unknown coefficients in the model which have to be identified. Because the BOF technology is stochastic and because heredity plays an important part in this technology, the identification procedure is repeated in each of the production cycles.

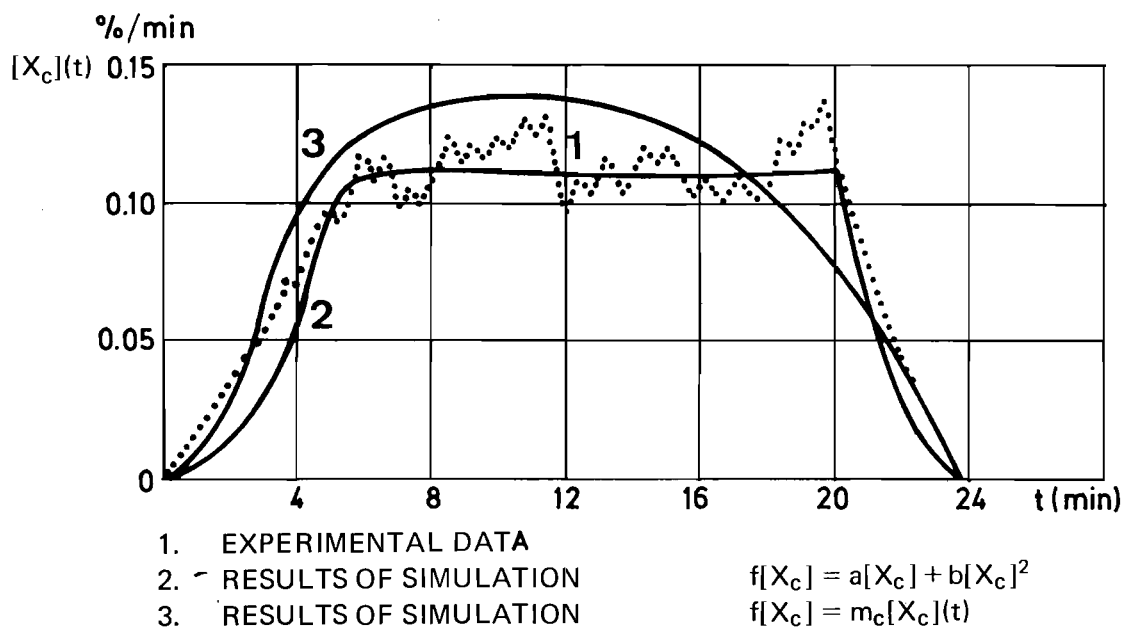

Figure 9.

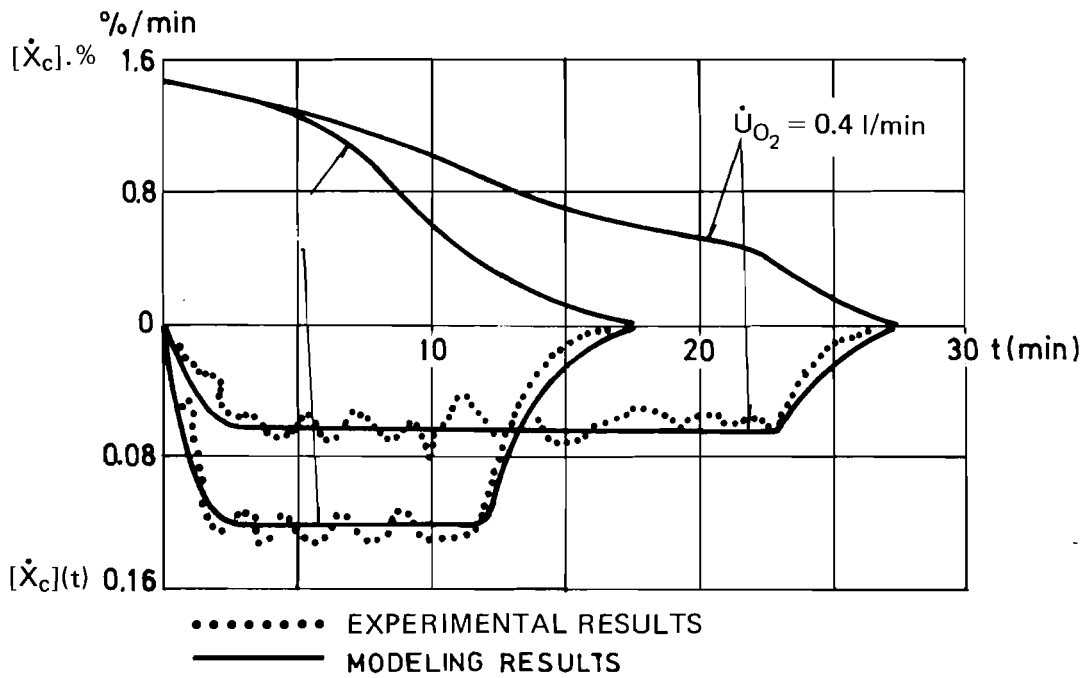
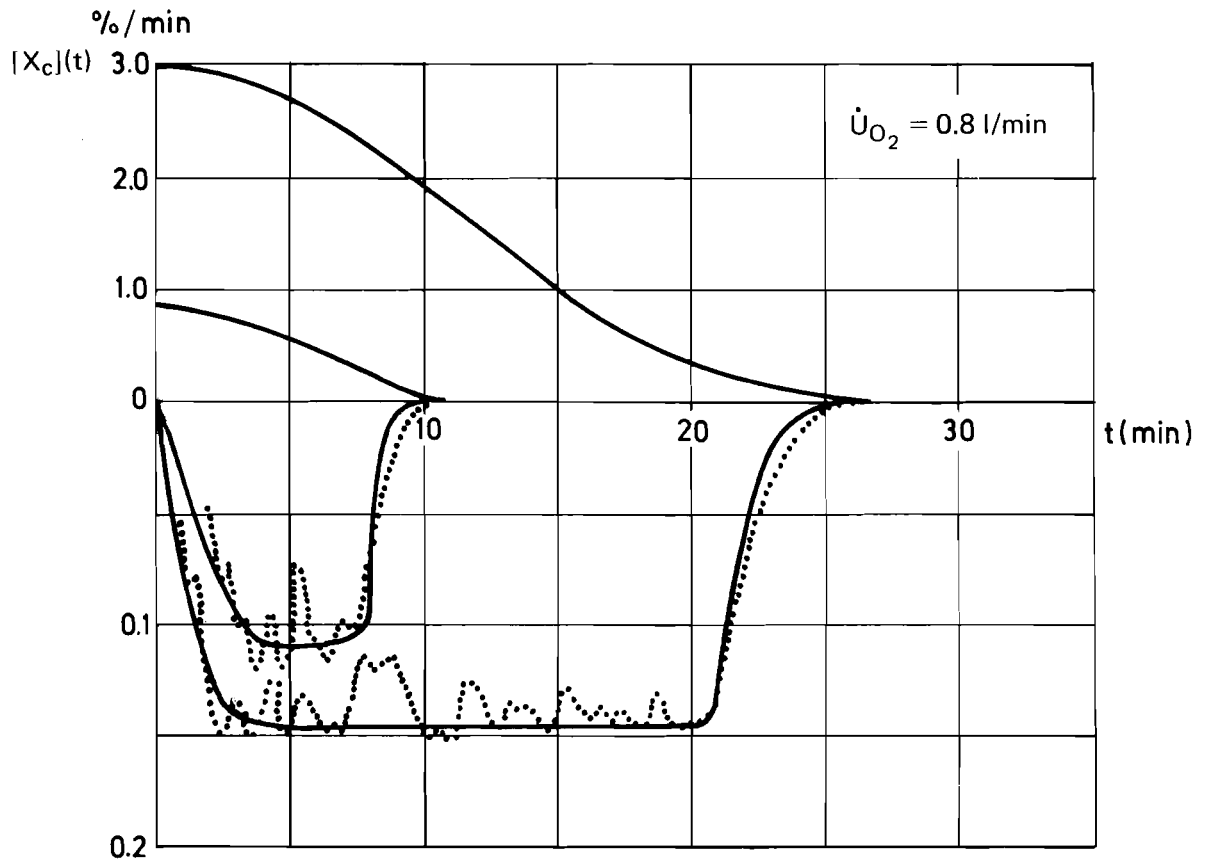

Figure 10.

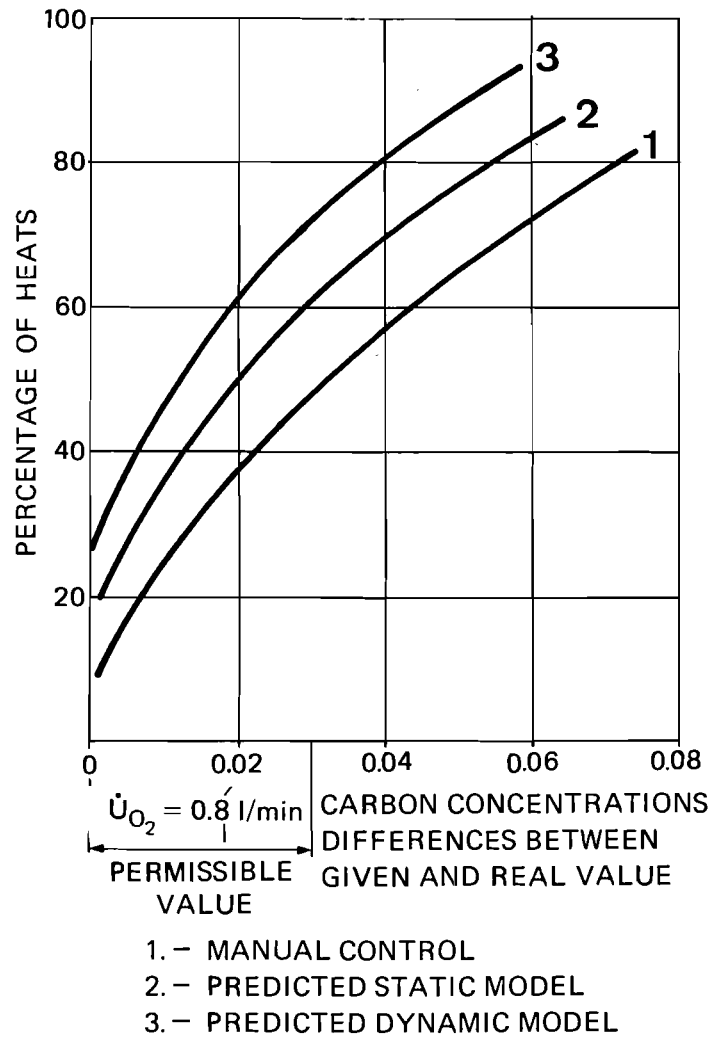

Figure 11.

The data for several previous production cycles may be used for determining the coefficients. Then, the subsequent production cycle can be predicted on the basis of this model, with the newly identified coefficients.

The model and adaptation algorithm was solved on a universal computer BESM-6, and the time required for this solution was 0.5 of a minute. This computer time is acceptable for a given production cycle.

Operational problem: to maximize the productivity of industrial complexes utilizing the BOF technology and the Continuous Casting Machine (CCM).

The most important part of the task is the coordination of the production cycle for both complexes. The duration of the BOF and the CCM cycles differ. To achieve better results (e.g. maximizing productivity), the frequency of the heat preparation in the oxygen converter complex should correspond to the productivity of the continuous casting machine. It is possible to achieve this by means of model scheduling. The scheduled model and the corresponding algorithm have been developed for short-term modeling of these complexes [10].

The whole production cycle being considered consists of three tasks: melting in BOF, preparing for casting and casting itself. The very complex BOF technology is considered a single task within the overall system and maybe described by simple models as well as by other tasks in this production cycle.

The mathematical models of these cycles are shown in Figure 12. In this model:

- $x^{ij}(t)$: portion of the ij^{th} task performed to the moment t . It could be interpreted as a portion of the total time T_{ij} the tasks required for its performance until the moment t ;
- $U^{ij}(t)$: performance intensity of part of the ij^{th} has been completed within $[t-1, t]$ period;
- $\theta(y)$: $\begin{cases} 0 & \text{if } y < 0 \\ 1 & \text{if } y \geq 0 \end{cases}$

The number of converters, m and the number of continuous casting machines, n are considered:

$$\sum_{k=1}^S a_k U^{3k-2}(t) \leq m$$

$$\sum_{k=1}^S b_k U^{3k}(t) \leq n$$

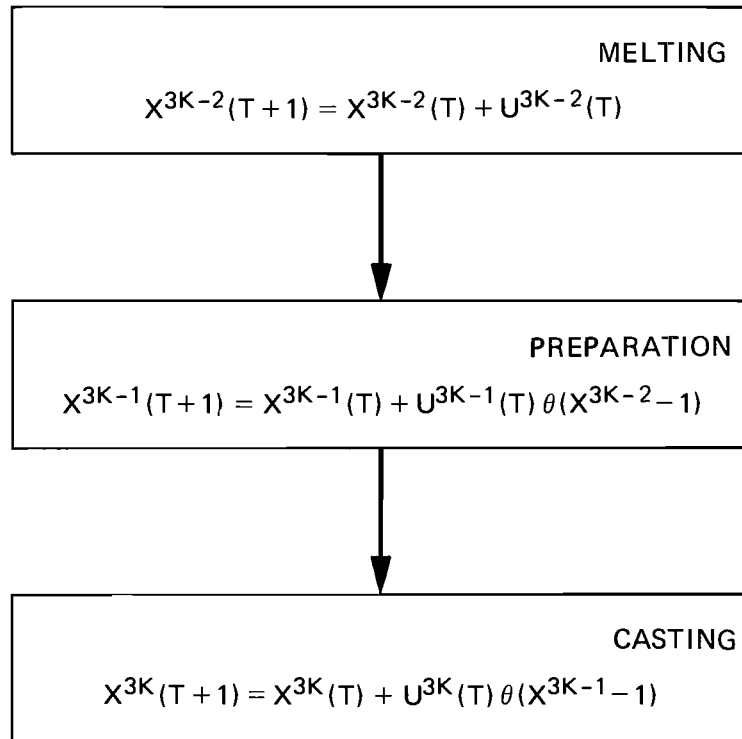

Figure 12.

where

a_k : time required to complete the $(3k-2)^{\text{th}}$ melting; and
 b_k : time required to complete the $3k^{\text{th}}$ casting.

The objective function $I(u) = T$ is the time of completion of all cycles. The model is a system of dynamic finite-difference equations.

The algorithm used for solving this problem is based on the successive approximation method, and on standard procedures (e.g. simplex method). These scheduled models should also be solved in real time in order to predict the actual state of the complexes. The CDC-6600 computer has been used for solving this task. An 0.1-second computer time was needed for this solution.

The results of the simulation done on the real data have been written in the form of a Ghand Diagram (Figure 13). Figure 13a shows the sequence of the tasks for five production cycles by the three BOF and four CCM's available. Figures 13b and 13c show the resource loading during the time. This model and the algorithm can be used for both the operational management of the industrial complexes and for design purposes. The optimal number of BOF and CCM's can be chosen to achieve the required productivity.

Research problem: to increase the metal yield from a charge, on the basis of optimizing the parameters of the process.

Investigations and experiments are made on operating units and laboratories. One type of investigation is simulation.

Several constraints of the model can be formulated, e.g. the model should describe the main processes which influence the metal yield particularly the Fe-balance.

The model should be solved off-line, and can have any complexity; process data are available for model adaptation; the solution time is unlimited; the demand for model accuracy is not very high. Taking these constraints into consideration, the combined experimental-analytical approach can be utilised to develop the mathematical model (see AB in Figure 4). Figure 14 shows the scheme of the model. The oxygen throughput, the position of lance and the weight of additional agents are the input parameters. Metal composition, temperature and metal yield are the output parameters. The charge composition and the temperature of pig iron are the initial conditions.

The model is a system of 48 linear and non-linear equations including 13 differential equations. Two types of computers have been used for solving this model. The analog MN-17 computer has been used for the structural identification of the preliminary model. The universal M-220 computer has been used for detailed simulation types of technology. The solution of the models demand about 5 minutes of computer time.

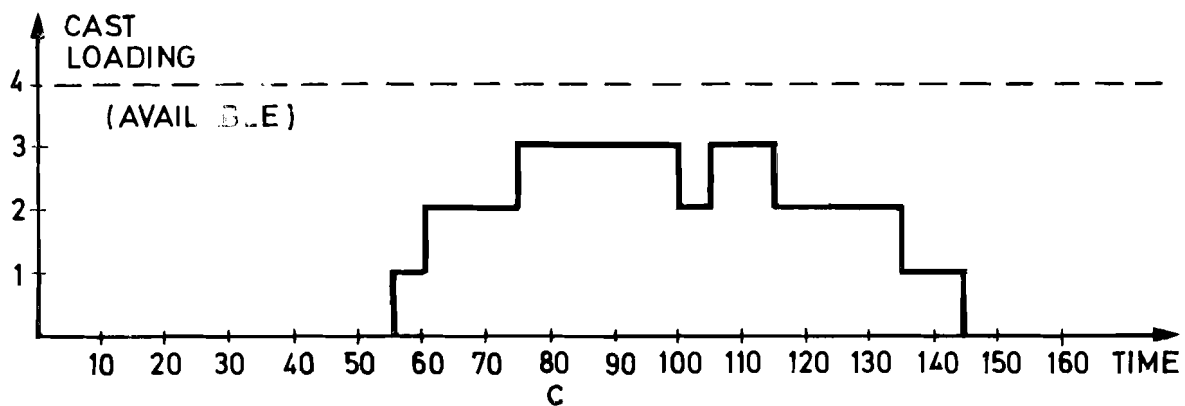
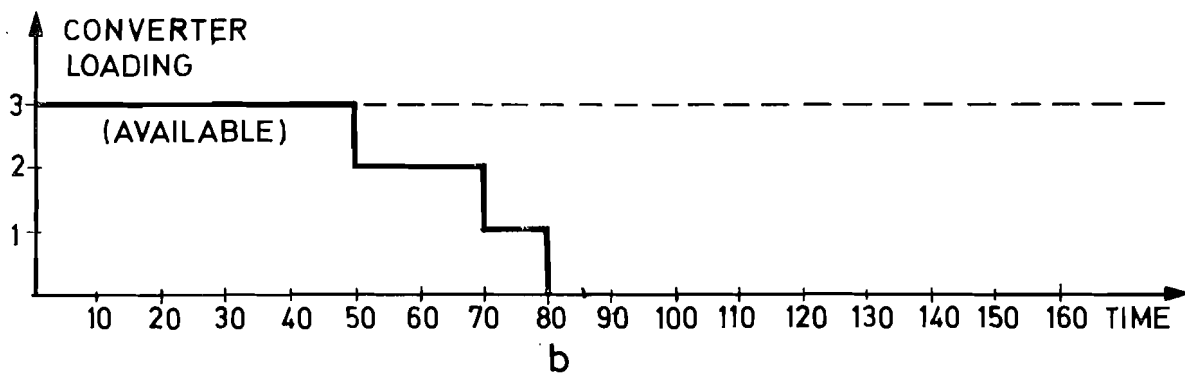
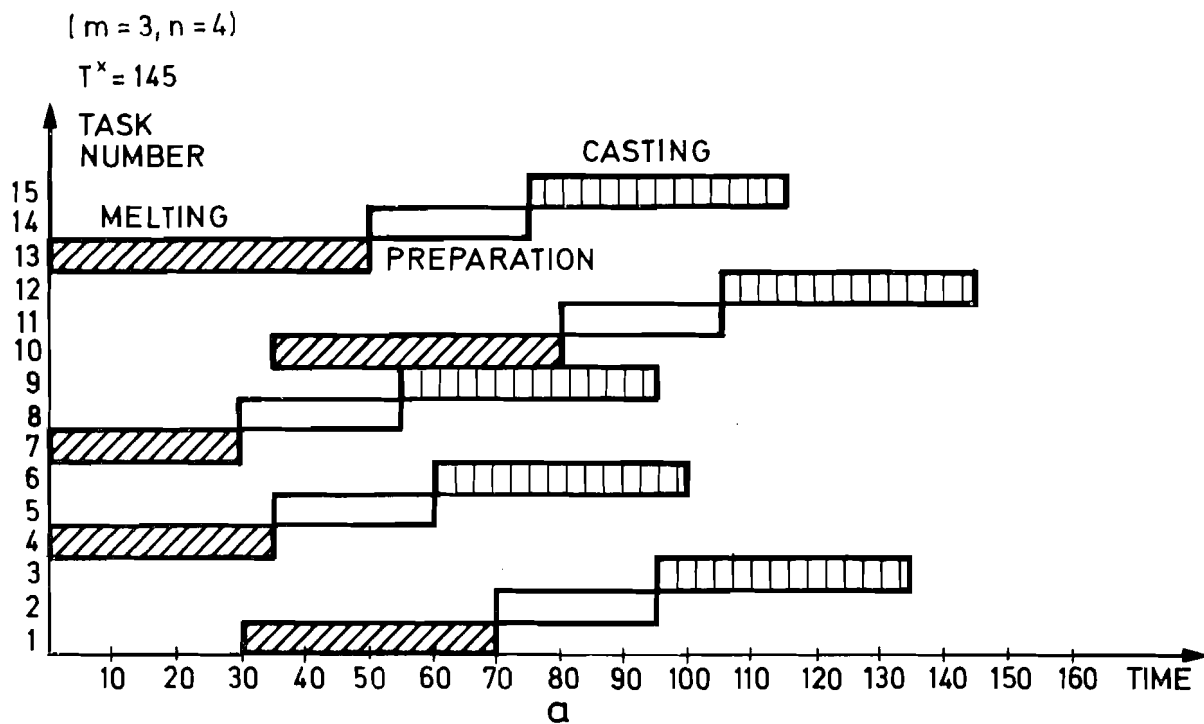

Figure 13.

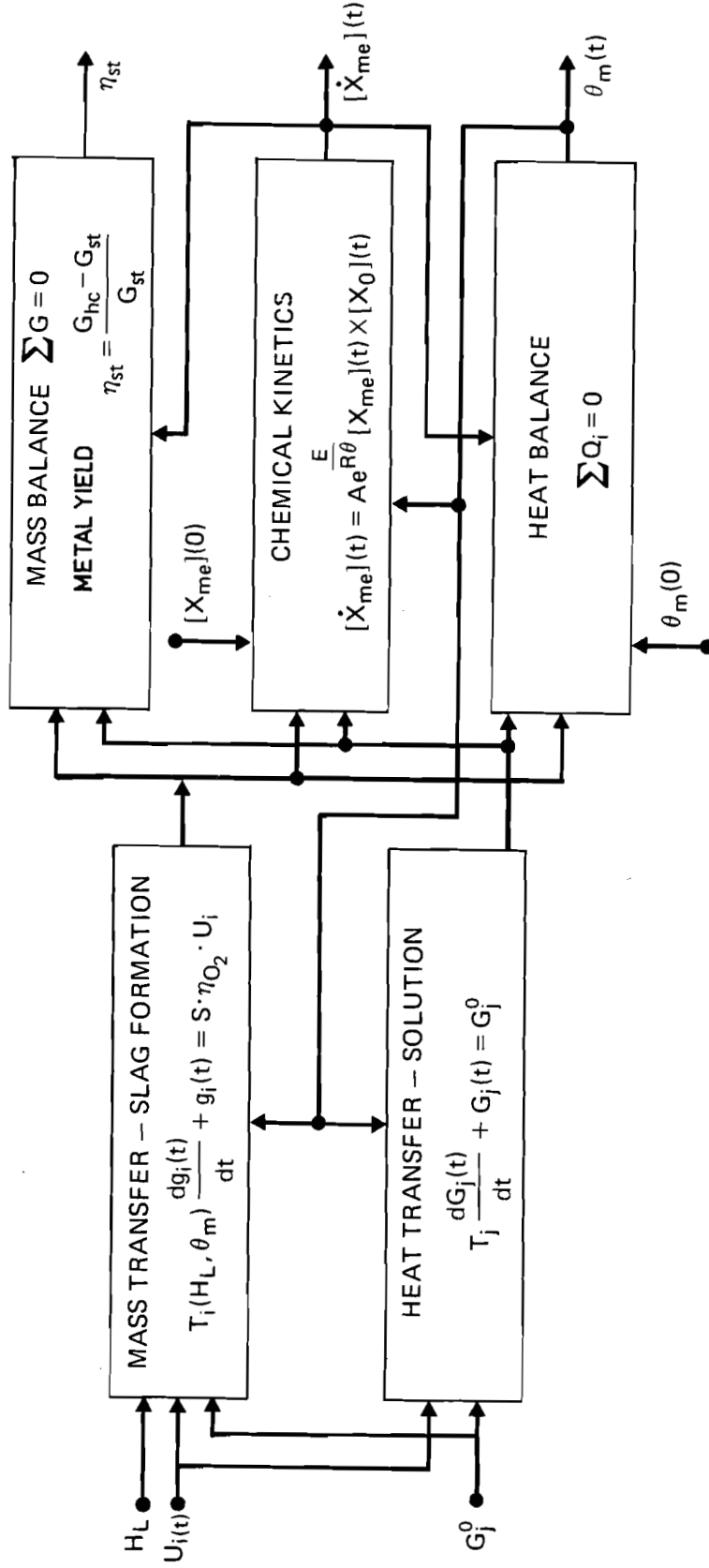

Figure 14.

The influence of different parameters on the metal yield has been investigated. Figure 15 shows the influence of the oxygen throughput and the position of the lance on the metal yield. This function is important because with respect to the use of BOF technology the modern trend is to increase the specific oxygen consumption from 2 to 6-7 m³/t/min. in order to achieve greater productivity. Increasing the Fe_o quantity in the slag and the Fe waste results in a decrease of the metal yield. Figure 15 also shows the influence of the position of the lance on the metal yield.

The fraction of scrap in the charge is another important factor for the steel industry and for BOF in particular (Figure 16). The maximum metal yield is obtained with about 25 percent scrap in the charge.

A decrease of scrap is compensated for by the fluid pig iron in a composition where there are additional elements such as approximately 4.5% C, 1.0% Mn, 0.5% Si and 0.2% P. These elements are oxidized during the process, thus the metallic yield is decreased (see the left hand side of the maximum in Figure 16). An increase of scrap in the charge could disturb the heat balance in the melting process. To compensate this disturbance, the total value of Fe should be oxidized. In turn this results in the decrease of the metal yield.

Design problem: for designing of continuous steelmaking processes, it is necessary to determine the conditions for the stability of the ongoing processes.

The stability of the processes depends on the capability of the furnaces, productivity, storage, etc. Figure 17 shows the scheme of a continuous steelmaking installation. The ongoing processes in each of the furnaces are typical of the BOF technology. The need for coordinating the combined work of all the furnaces should be taken into consideration in the design of the technology.

The main purposes of the model are to describe the dynamic behavior of the process parameters, and to choose the optimal construction and conditions which will ensure the successful operational control of all furnaces. This is another example of the interconnection of the design and the operational control problems.

For the model's input parameters, the oxygen and fuel rate have been considered. The controllable quantities (output parameters) are the carbon concentration and temperature. The special characteristic of this new technology is the metal flow from one furnace to another, which was taken into account by the model builders. The equations for the metal flow are as follows:

$$\dot{G}_i(t) = \text{constant}$$

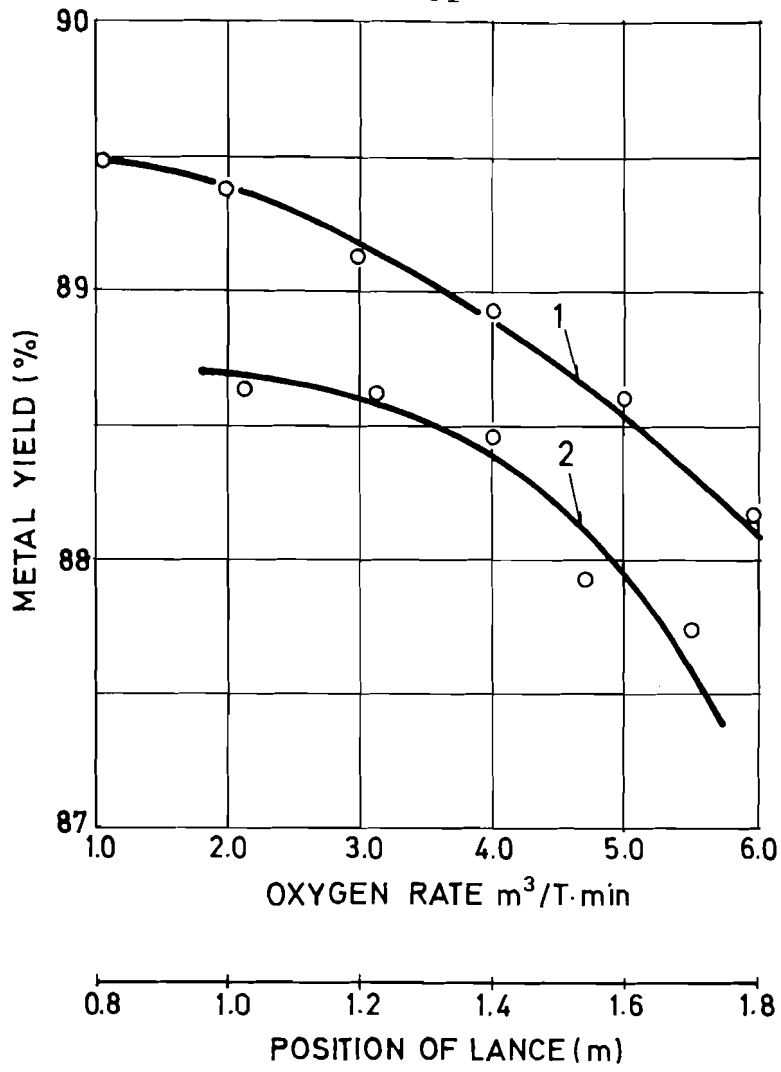

Figure 15.

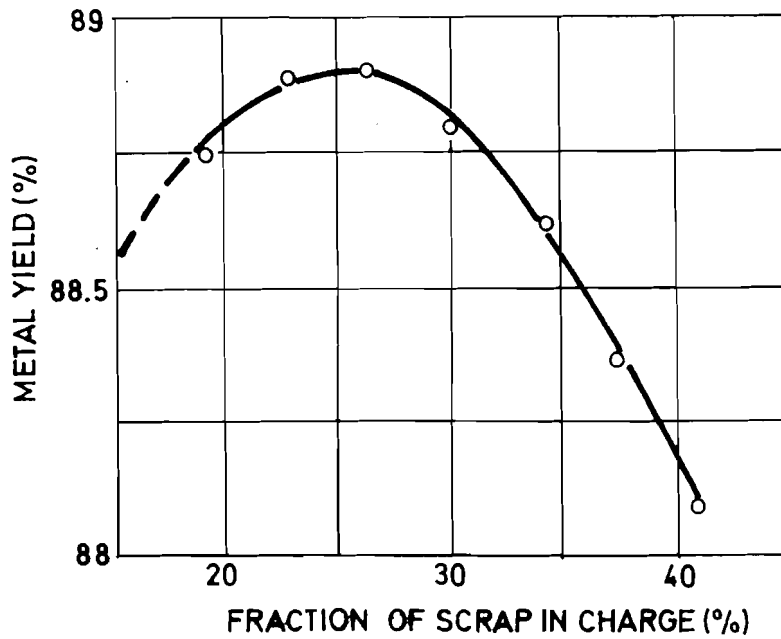

Figure 16.

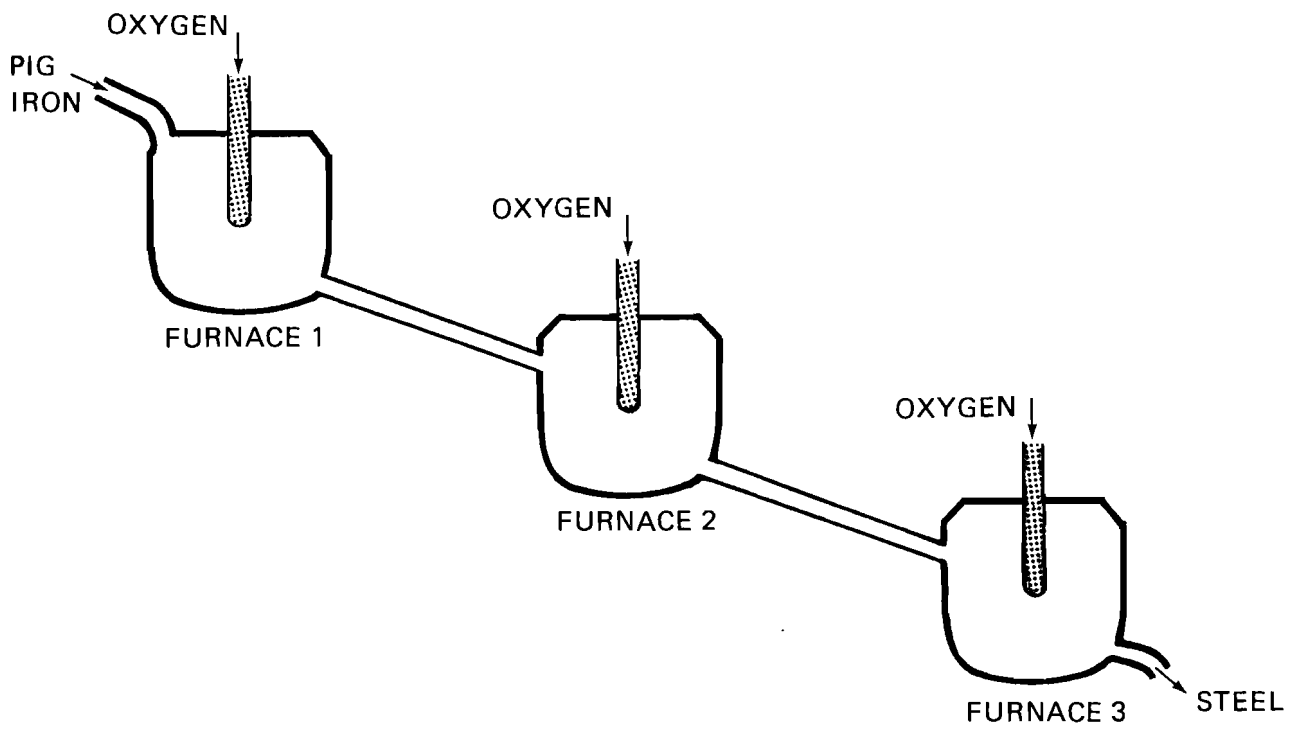

Figure 17.

where

$G_i(t)$: metal flow through the i^{th} converter

A block diagram of the mathematical model is given in Figure 18. The model is composed of three blocks, each describes the process in one bath. The processes in each bath are described based on the basic laws of mass action and mass and heat conservation. The oxygen rate of element $d[X_{me}]$ is calculated according to the law of heat conservation. $\frac{d[X_{me}]}{dt}$
Clearly,

$$[X_{me}]_{(i-1)}^{\text{out}} = [X_{me}]_i^{\text{in}},$$

$$G_{(i-1)}^{\text{out}} = G_i^{\text{in}},$$

$$\theta_{(i-1)}^{\text{out}} = \theta_i^{\text{in}}$$

Approximately 20 equations, including 10 non-linear differential equations are contained in the model. The Soviet analog computer MH-17 was implemented to simulate the model. There are no data for developing and verifying the models because the modeling technology does not exist. At the same time, valuable information can be acquired on the simulation process, which is helpful in the development of a new technology.

Many static and dynamic characteristics have been acquired as a result of mathematical modeling; Figure 19 shows one of them, namely - the dynamics of carbon concentration in each converter. The changing of the carbon concentration $[X_c]_1^{\text{in}}$, which has been done in four hours, is compensated in the first furnace ($[X_c]_1^{\text{out}} = [X_c]_2^{\text{in}}$) during one hour, and in the third furnace ($[X_c]_3$) for approximately two hours. Thus it is possible to choose different conditions for process realization.

GENERALIZATIONS

Solutions to problems of one type of technology demand the development of different types of models. Some characteristics of the tasks and models discussed are shown in Table 5. This Table details the characteristics already shown in Table 1. Table 5 gives the characteristics of the tasks within the framework of the problems being considered, and the general demands of the models which result from the type of tasks formulated. It also shows the methods for model development, the characteristics, the computer utilized for the solution, and the relative error. The final characteristic is the utilization of the model.

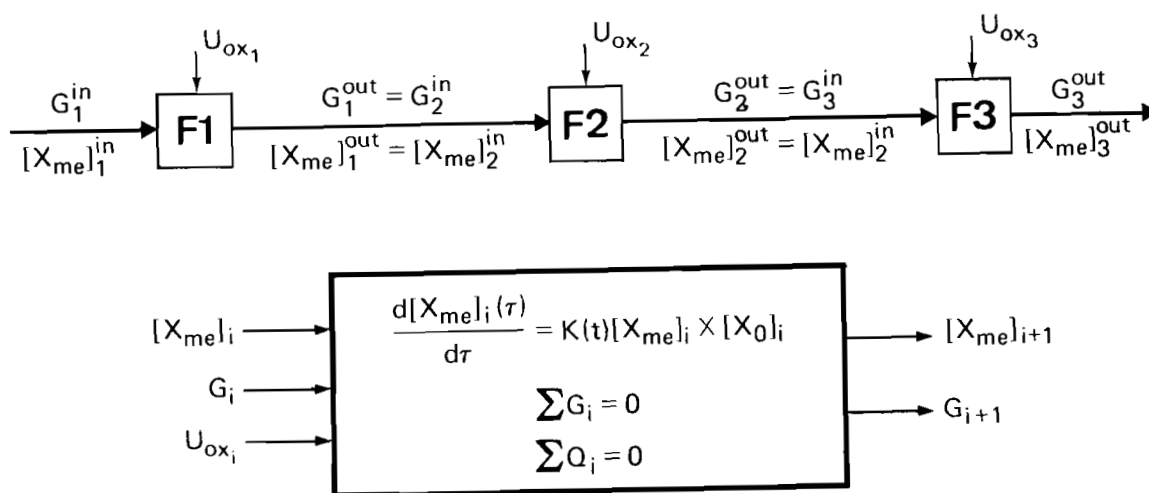

Figure 18.

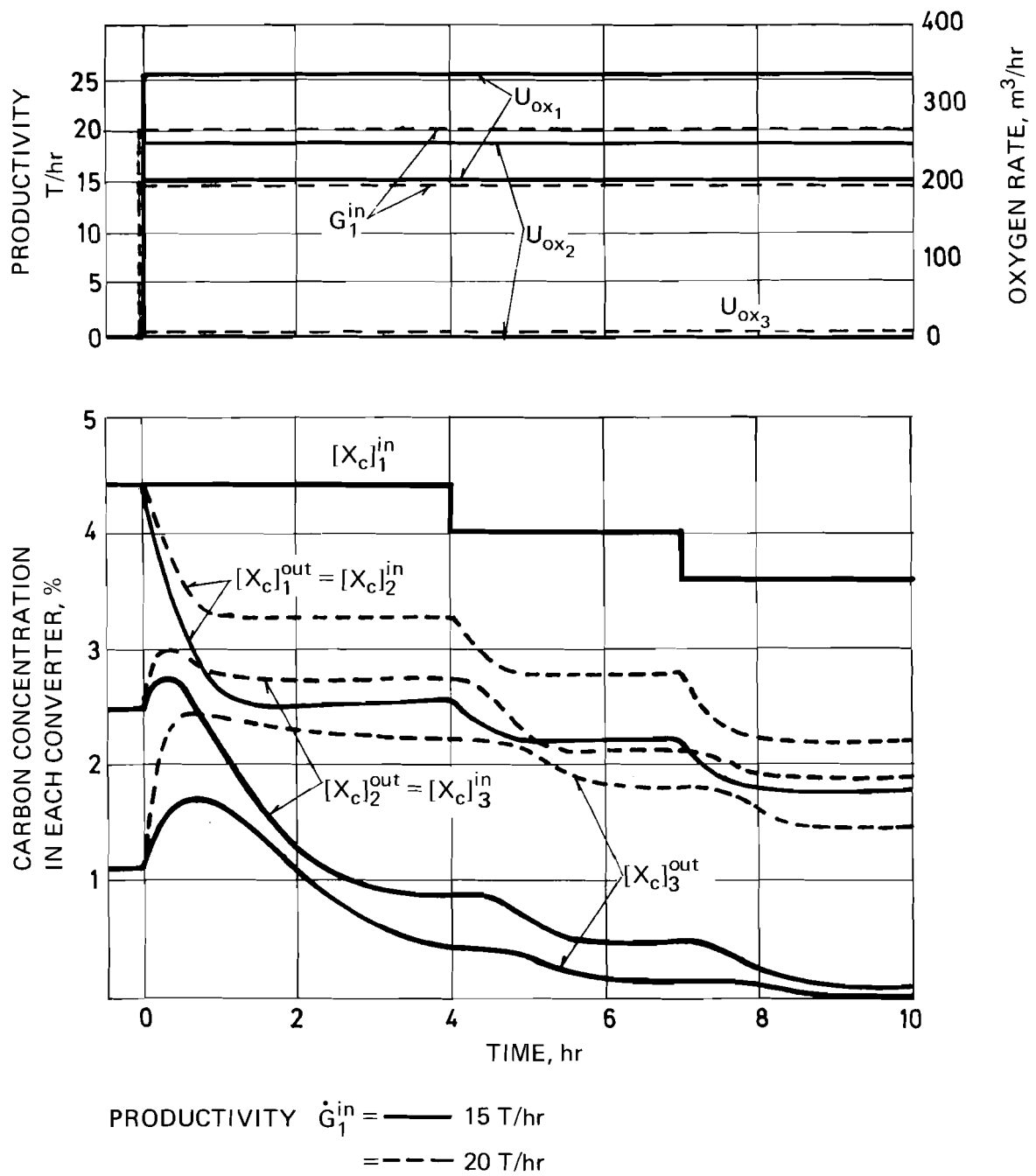

Figure 19.

Table 5.

Problems Characteristics	Operational Control			Research	Design
	1	2	3		
Task characteristics		2 To maximize the percentage of the heats produced in a given value of output parameters	3 To maximize the productivity of industrial complexes, which consist of BOF and the Continuous Casting Machine	4 To increase the metal yield from the charge on the basis of optimization of the process parameters	5 To design a new continuous steel-making technology to determine the technological conditions which provide the stability ongoing in the process
General demand of Model		Connection of input-output parameters in static (a) or dynamic (b)	Connection of general BOF technology indices with general indices of Continuous Casting Machine	Detailed description of Fe behavior in BOF	Dynamic connection between separate furnaces
Method of Model development		Experimental - statistical	Analytical (heuristic)	Combined	Analytical
Characteristic of Models		a) System of 2 linear regression equations of 1st order b) System of eight non-linear differential equations of 1st order	System of three finite differential equations	System of 48 non-linear equations, including 13 differential	System of 24 non-linear equations, including 10 differential

Table 5. (cont.)

Problems Characteristics	Operational Control		Research	Design
	2	3		
1			4	5
Computer Utilization	BESM-6 (universal)	PDP-11 (universal)	MN-17 (analog) M-220 (universal)	MN-17 (analog)
Relative error	≤ 3%	not available	≤ 10%	≤ 15%
Applied Utilization	Implemented for Operational Control The number of heats which are produced for a given value are increased by 10-20%	not implemented	Implemented for choice of optimal technological conditions which maximize the metal yield.	Implemented for choice of technological and construction elements for designing new technology

Some characteristics of the models and some problems which have been discussed are shown in Figure 20. The model uncertainty increases in succession for operational management and control, research and development and design. The accuracy achieved is decreased in a given order. The complexity of the model and model aggregation attributes can have different relationships in research and design problems. In operational problems these attributes have a magnitude corresponding more to simplified and aggregation models.

SUMMARY

Improving the efficiency of industrial technology and developing advanced technology can be achieved by means of operational control and management, research and development and design. These three problem areas demand the development of problem-oriented mathematical models. The whole modeling technique - the study of a system under modeling, the method for mathematical description, the choice of algorithm, computer programming, model verification, etc. depend on the problems to be solved, the systems approach manifests itself within these.

It is irrational and may be impossible to develop the universal models which can solve all problems or a large part of them. Some examples were given of mathematical models in steelmaking technology in BOF.

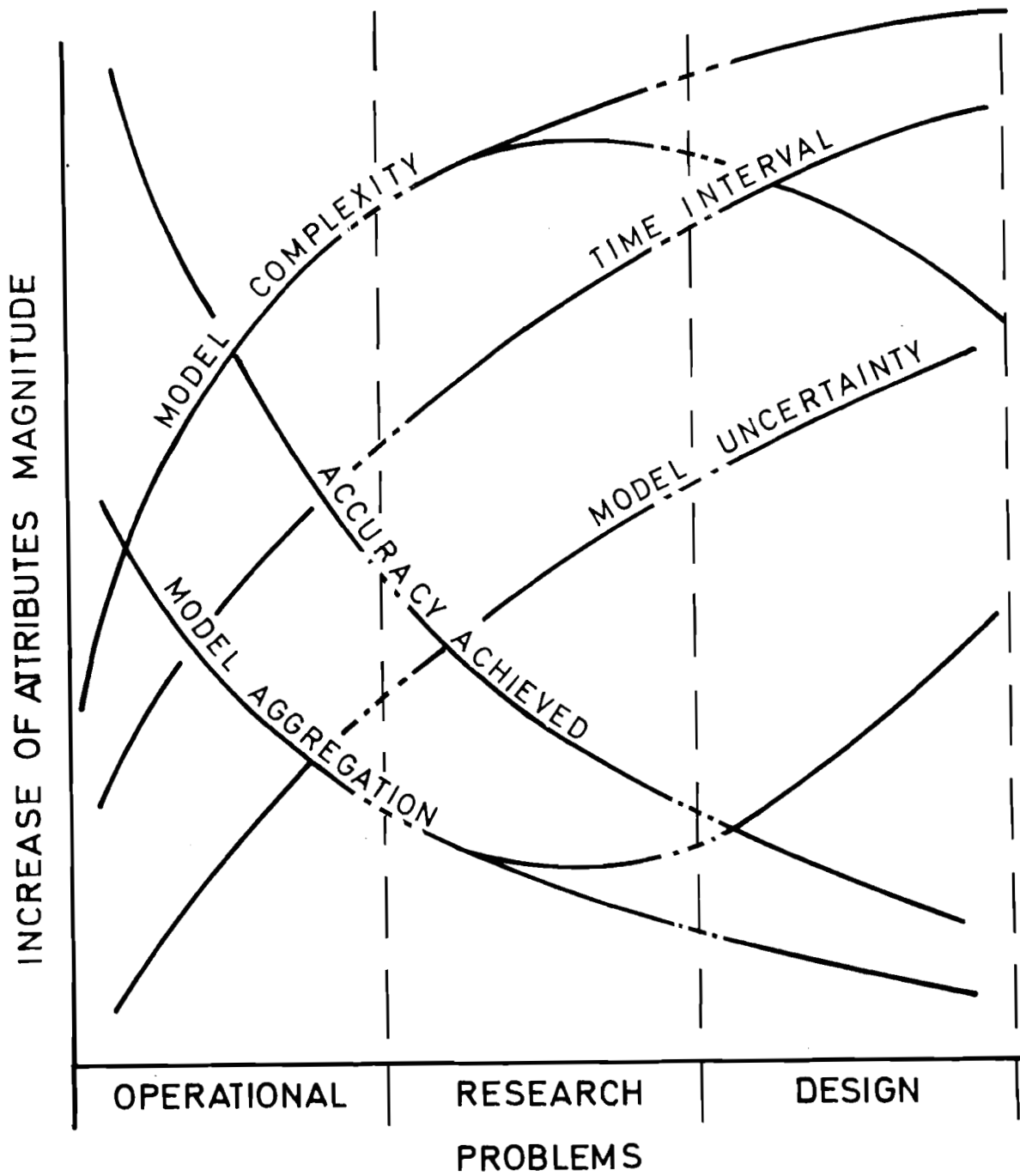

Figure 20.

REFERENCES

- [1] Gross, N., D. Elliot and R. Roy, Eds. *Man-made Future: Readings in Society, Technology and Design* Hutchinson Educational.
- [2] Walker, R.D., Modern Iron and Steelmaking Techniques, in *The Metallurgist and Materials Technologist*, January (1975), 23-27.
- [3] Warren, K., *World Steel and Economic Geography*, Crane-Russak & Co. Inc., 1975.
- [4] International Meeting on Iron and Steel Making 1976, Volume Ib, European Community for Steel and Coal, Brussels, 1976.
- [5] Gyftopoulos, E.P., L.J. Lazaridis and T.F. Widiner, *Potential Full Effectiveness in Industry*, Ballinger, Cambridge, Mass. 1974.
- [6] Surguchov, G.D., E. Derkatschov and G. Massalow, The Possibility of Controlling the LD Process on the Basis of a Dynamic Model, in *Berg und Huttenmännische Monatshefte*, 7, (1973) in German.
- [7] Kainz, K., E. Eibe and A. Krauze, Process Models for the Automation of the LD Process, in *Berg- und Huttenmännische Monatshefte*, 11 (1974), 344-353, in German.
- [8] Mehra, R.K. and C.H. Wells, Dynamic Modeling and Estimation of Carbon in a Basic Oxygen Furnace, Presentation at the Third International IFAC/IFIP Conference, Helsinki, June 2-5, 1971.
- [9] Loeb, J. and G. Gahen, *Automatisme*, *AF CET*, December 1963, 9, in French.
- [10] Zimin I. and Surguchov G.D., *Short-term Planning of an Integrated Industrial Complex*, RM-75-13, International Institute for Applied Systems Analysis, Laxenburg, Austria, 1975.